

# DFNWB0.6x0.3-2L-B Plastic-Encapsulate Diodes

## DS751-40EAA02 SCHOTTKY BARRIER DIODE

### FEATURE

- Small surface mounting type
- Low reverse current and low forward voltage
- High reliability

### APPLICATION

- High speed switching for detection
- For portable equipment:(i.e. Mobile phone,MP3, MD,CD-ROM, DVD-ROM, Note book PC, etc.)

### MARKING

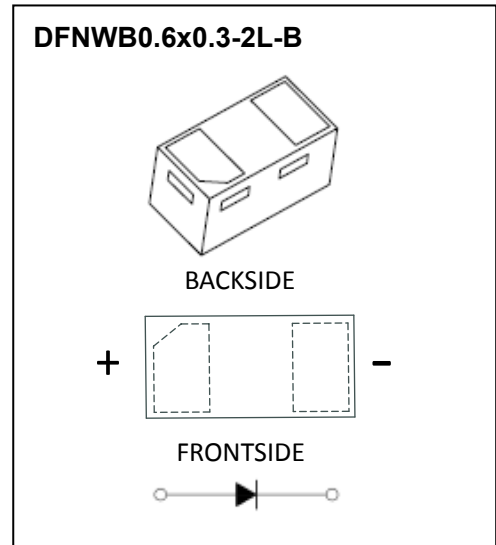

### MAXIMUM RATINGS (T<sub>a</sub>=25°C unless otherwise noted)

Symbol	Parameter	Limit	Unit
V <sub>RRM</sub>	Repetitive Peak Reverse Voltage	40	V
V <sub>RWM</sub>	Working Peak Reverse Voltage		
V <sub>R(RMS)</sub>	RMS Reverse Voltage	28	V
I <sub>O</sub>	Average Rectified Output Current	30	mA
I <sub>FSM</sub>	Non-Repetitive Peak Forward Surge Current@ t=8.3ms	200	mA
P <sub>d</sub>	Power Dissipation	100	mW
R <sub>θJA</sub>	Thermal Resistance from Junction to Ambient	1000	°C/W
T <sub>J</sub>	Junction temperature	125	°C
T <sub>stg</sub>	Storage Temperature	-55 ~ +150	°C

### ELECTRICAL CHARACTERISTICS (T<sub>a</sub> = 25°C unless otherwise specified)

Parameter	Symbol	Test Condition	Min	Typ	Max	Unit
Reverse breakdown voltage	V <sub>(BR)</sub>	I <sub>R</sub> =1mA	40			V
Reverse current	I <sub>R</sub>	V <sub>R</sub> =30V			0.5	μA
Forward voltage	V <sub>F</sub>	I <sub>F</sub> = 1mA			0.37	V
Capacitance between terminals	C <sub>T</sub>	V <sub>R</sub> =1V,f=1MHz		2		pF

# Typical Characteristics

**Forward Characteristics**

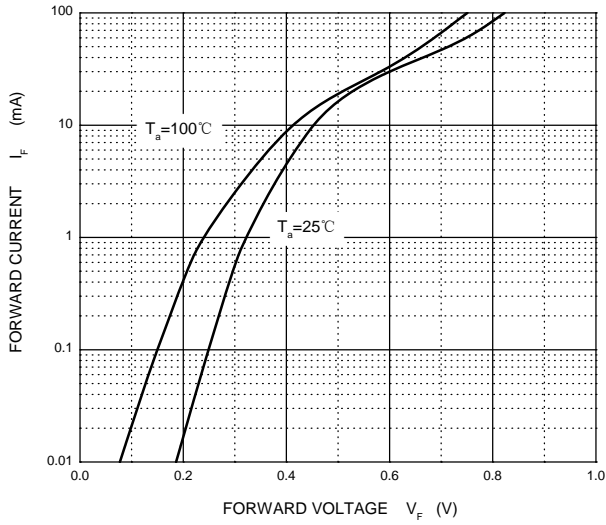

**Reverse Characteristics**

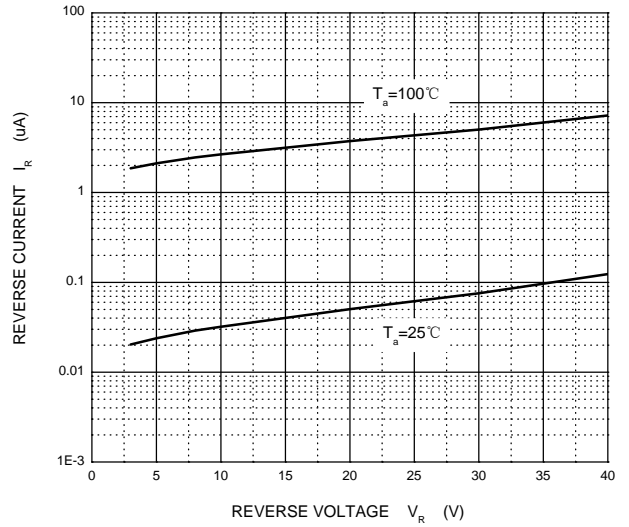

**Capacitance Characteristics**

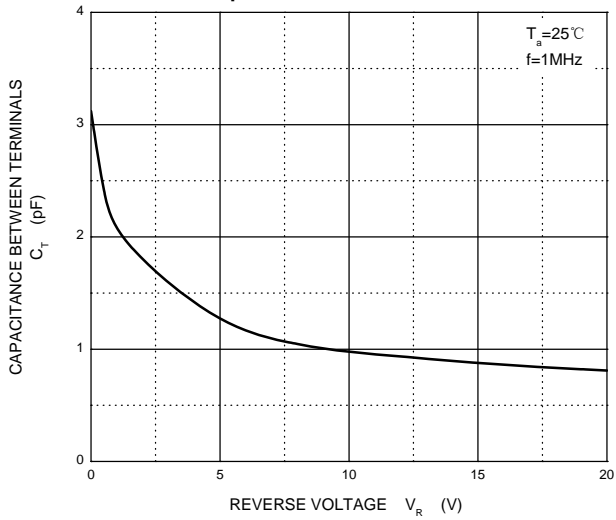

**Power Derating Curve**

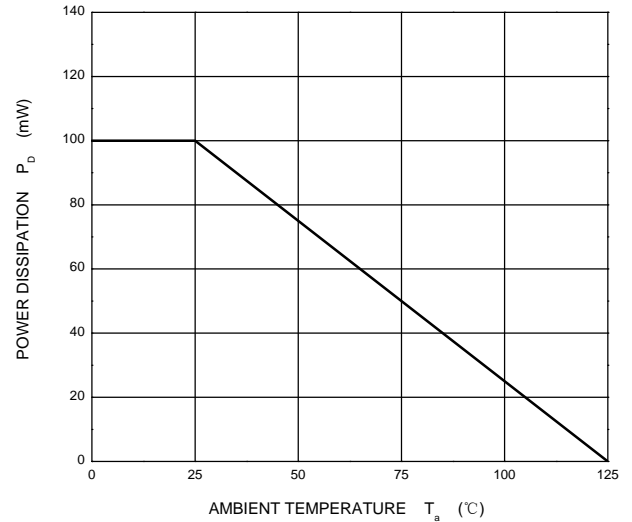

## DFNWB0.6x0.3-2L-B Package Outline Dimensions

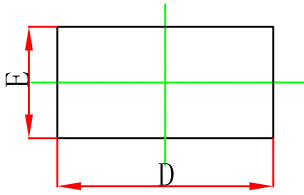

TOP VIEW  
[顶视图]

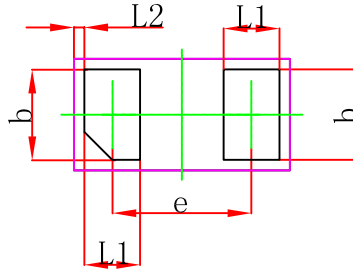

BOTTOM VIEW  
[背视图]

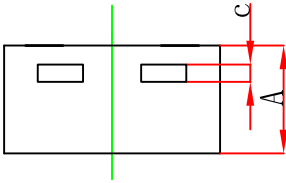

SIDE VIEW  
[侧视图]

Symbol	Dimensions In Millimeters		Dimensions In Inches	
	Min.	Max.	Min.	Max.
A	0.275 0	.340	0.011	0.013
D	0.570 0	.670	0.022	0.026
E	0.270 0	.370	0.011	0.015
b	0.225 0	.295	0.009	0.012
c	0.050 REF.		0.002 REF.	
e	0.365 0.	435	0.014	0.017
L1	0.125 0	.195	0.005	0.008
L2	0.030 REF.		0.001 REF.	

## DFNWB0.6x0.3-2L-B Suggested Pad Layout

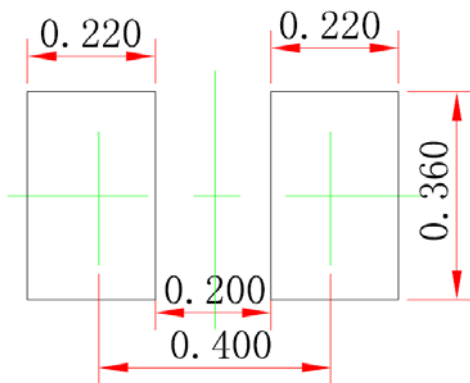

### Note:

1. Controlling dimension: in millimeters.
2. General tolerance:  $\pm 0.050\text{mm}$ .
3. The pad layout is for reference purposes only.

### NOTICE

JCET reserve the right to make modifications, enhancements, improvements, corrections or other changes without further notice to any product herein. JCET does not assume any liability arising out of the application or use of any product described herein.

# DFNWB0.6x0.3-2L-B Tape and Reel

## DFNWB0.6x0.3-2L-B Embossed Carrier Tape

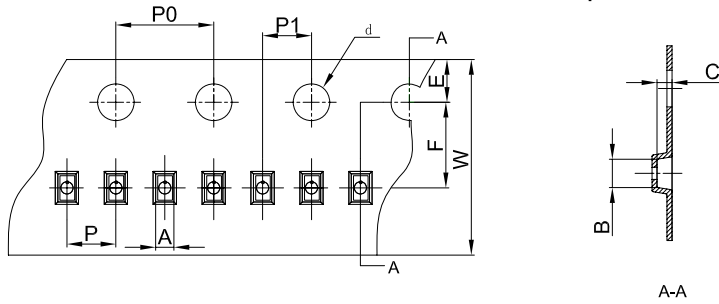

**Packaging Description:**  
 DFNWB0.6x0.3-2L-B parts are shipped in tape. The carrier tape is made from a dissipative (carbon filled) polycarbonate resin. The cover tape is a multilayer film (Heat Activated Adhesive in nature) primarily composed of polyester film, adhesive layer, sealant, and anti-static sprayed agent. These reeled parts in standard option are shipped with 10,000 units per 7" or 17.8cm diameter reel. The reels are clear in color and is made of polystyrene plastic (anti-static coated).  
 Note: If it is the product of the same polarity, the cathode line should be removed.

Dimensions are in millimeter										
Pkg type	A	B	C	d	E	F	P0	P	P1	W
DFNWB0.6x0.3-2L-B	0.41	0.70	0.23	Ø1.50	1.75	3.50	4.00	2.00	2.00	8.00
(Tolerance)	+/-0.05	+/-0.05	+/-0.02	+/-0.1	+/-0.1	+/-0.1	+/-0.1	+/-0.1	+/-0.1	+0.3/-0.1

## DFNWB0.6x0.3-2L-B Tape Leader and Trailer

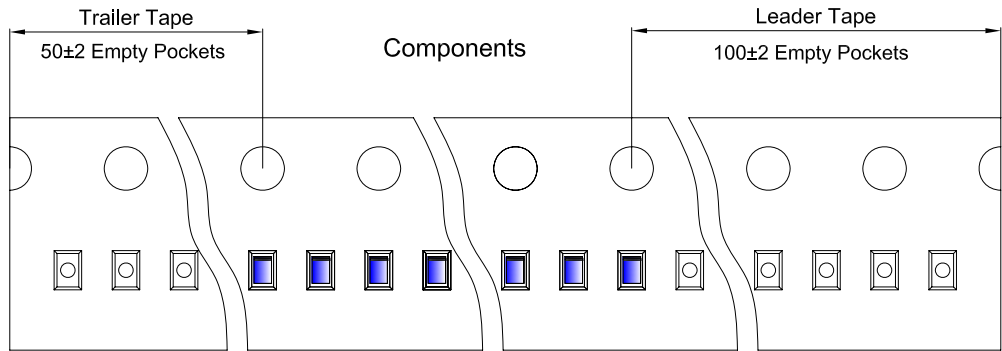

## DFNWB0.6x0.3-2L-B Reel

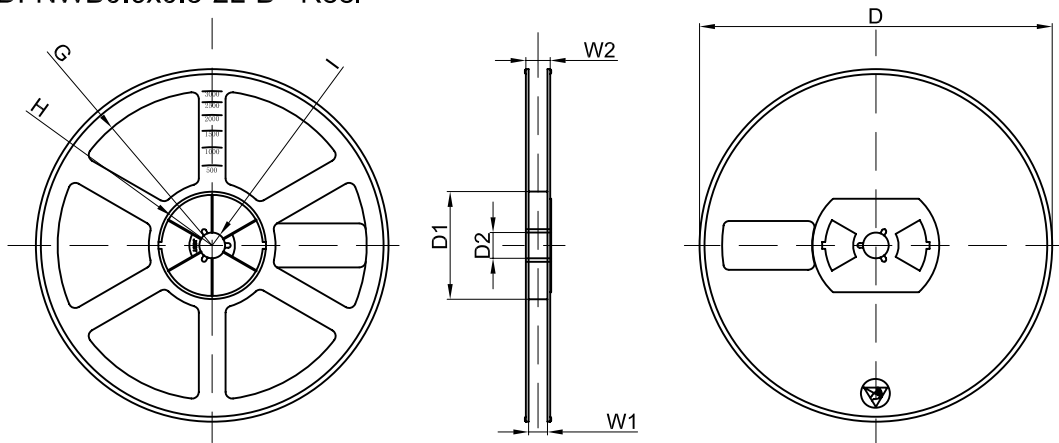

Dimensions are in millimeter								
Reel Option	D	D1	D2	G	H	I	W1	W2
7" Dia	Ø178.00	54.40	13.00	R78.00	R25.60	R6.50	9.50	12.30
Tolerance	+/-2	+/-1	+/-1	+/-1	+/-1	+/-1	+/-1	+/-1

REEL	Reel Size	Box	Box Size(mm)	Carton	Carton Size(mm)	G.W.(kg)
10,000 pcs	7 inch	150,000 pcs	203×203×195	600,000 pcs	438×438×220	