

Features:

- Advanced trench process technology
- avalanche energy, 100% test
- Fully characterized avalanche voltage and current

ID =84A
BV=60V
Rdson=8mΩ

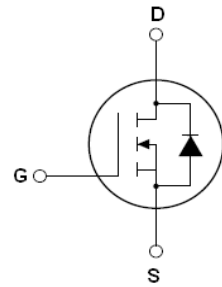

Description:

The SSF6008 is a new generation of high voltage and low current N-Channel enhancement mode trench power MOSFET. This new technology increases the device reliability and electrical parameter repeatability. SSF6008 is assembled in high reliability and qualified assembly house.

Application:

- Power switching application

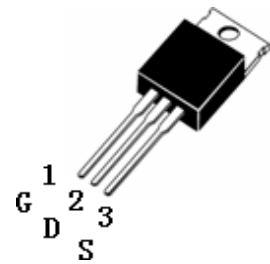

SSF6008TOP View (T0-220)

Absolute Maximum Ratings

	Parameter	Max.	Units
$I_D@T_c=25\text{ }^\circ\text{C}$	Continuous drain current, VGS@10V	84	A
$I_D@T_c=100\text{ }^\circ\text{C}$	Continuous drain current, VGS@10V	76	
I_{DM}	Pulsed drain current ①	310	
$P_D@T_c=25\text{ }^\circ\text{C}$	Power dissipation	181	W
	Linear derating factor	1.5	W/ C
V_{GS}	Gate-to-Source voltage	± 20	V
E_{AS}	Single pulse avalanche energy ②	400	mJ
E_{AR}	Repetitive avalanche energy ①	20	mJ
dv/dt	Peak diode recovery voltage	30	v/ns
T_J T_{STG}	Operating Junction and Storage Temperature Range	-55 to +175	°C

Thermal Resistance

	Parameter	Min.	Typ.	Max.	Units
$R_{\theta JC}$	Junction-to-case	—	0.83	—	°C/W
$R_{\theta JA}$	Junction-to-ambient	—	—	62	

Electrical Characteristics @TJ=25 °C (unless otherwise specified)

	Parameter	Min.	Typ.	Max.	Units	Test Conditions
BV_{DSS}	Drain-to-Source breakdown voltage	60	—	—	V	$V_{GS}=0V, I_D=250\mu A$
$R_{DS(on)}$	Static Drain-to-Source on-resistance	—	5.5	8	mΩ	$V_{GS}=10V, I_D=30A$
$V_{GS(th)}$	Gate threshold voltage	2.0	—	4.0	V	$V_{DS}=V_{GS}, I_D=250\mu A$
I_{DSS}	Drain-to-Source leakage current	—	—	2	μA	$V_{DS}=60V, V_{GS}=0V$
		—	—	10		$V_{DS}=60V, V_{GS}=0V, T_J=150\text{ }^\circ\text{C}$
I_{GSS}	Gate-to-Source forward leakage	—	—	100	nA	$V_{GS}=20V$
	Gate-to-Source reverse leakage	—	—	-100		$V_{GS}=-20V$

Q_g	Total gate charge	—	90		nC	$I_D=30A, V_{GS}=10V$ $V_{DD}=30V$
Q_{gs}	Gate-to-Source charge	—	18	—		
Q_{gd}	Gate-to-Drain("Miller") charge	—	28	—		
$t_{d(on)}$	Turn-on delay time	—	18.2		nS	$V_{DD}=30V$ $I_D=2A, R_L=15\Omega$ $R_G=2.5\Omega$ $V_{GS}=10V$
t_r	Rise time	—	15.6			
$t_{d(off)}$	Turn-Off delay time	—	70.5			
t_f	Fall time	—	13.8			
C_{iss}	Input capacitance	—	3150		pF	$V_{GS}=0V$ $V_{DS}=25V$ $f=1.0MHz$
C_{oss}	Output capacitance	—	300			
C_{rss}	Reverse transfer capacitance	—	240			

Source-Drain Ratings and Characteristics

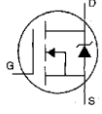
	Parameter	Min.	Typ.	Max.	Units	Test Conditions
I_S	Continuous Source Current. (Body Diode)	—	—	84	A	MOSFET symbol showing the integral reverse p-n junction diode. 
I_{SM}	Pulsed Source Current (Body Diode) ①	—	—	310		
V_{SD}	Diode Forward Voltage	—	—	1.3	V	$T_J=25^\circ C, I_S=60A, V_{GS}=0V$ ③
t_{rr}	Reverse Recovery Time	—	57	—	nS	$T_J=25^\circ C, I_F=75A$
Q_{rr}	Reverse Recovery Charge	—	107	—	μC	$di/dt=100A/\mu s$ ③
t_{on}	Forward Turn-on Time	Intrinsic turn-on time is negligible (turn-on is dominated by $L_S + L_D$)				

Notes:

- ① Repetitive rating; pulse width limited by max junction temperature.
- ② Test condition: $L = 0.3mH, V_{DD} = 30V, I_D=37A$
- ③ Pulse width $\leq 300\mu s$, duty cycle $\leq 1.5\%$; $R_G = 25\Omega$ Starting $T_J = 25^\circ C$

EAS Test Circuit:

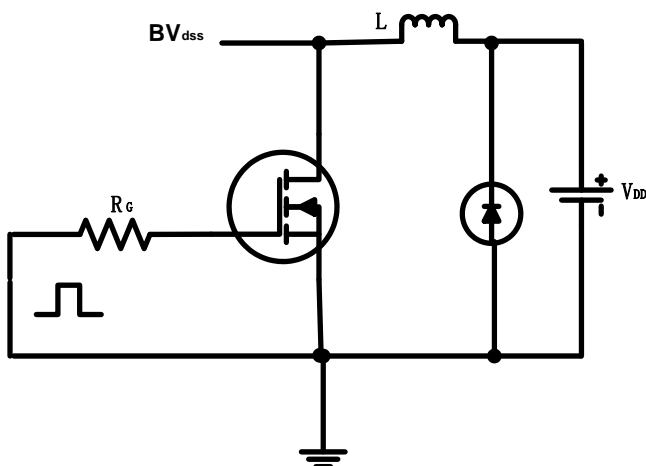

Gate Charge Test Circuit:

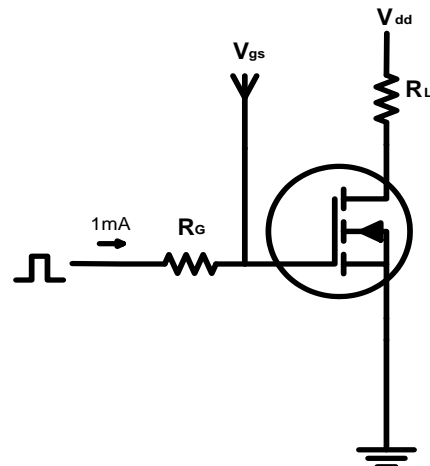

Switch Time Test Circuit:

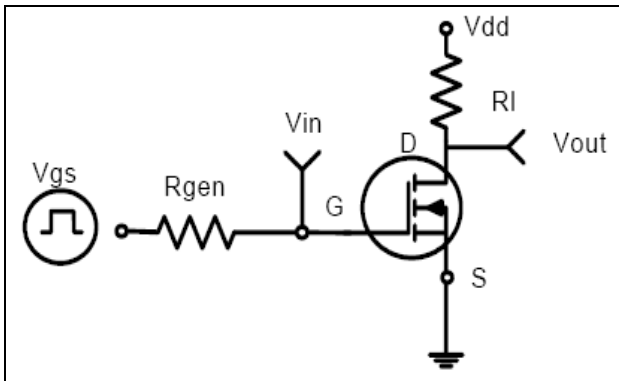

Switch Waveform:

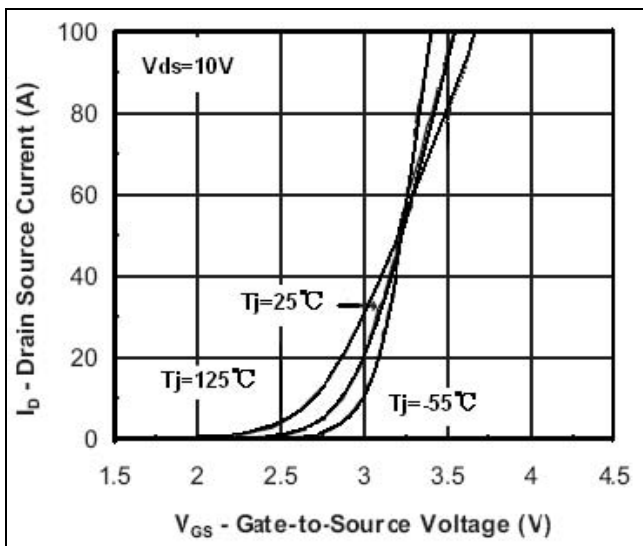
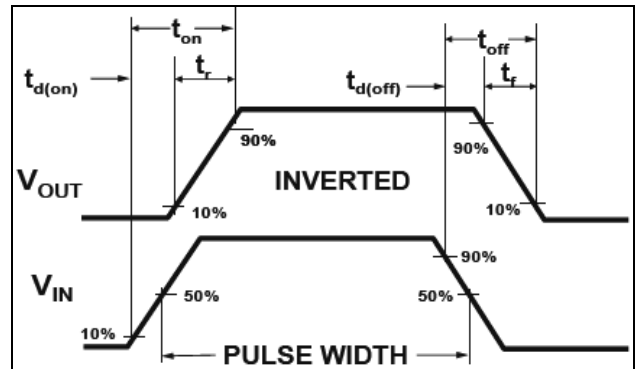

Transfer Characteristic

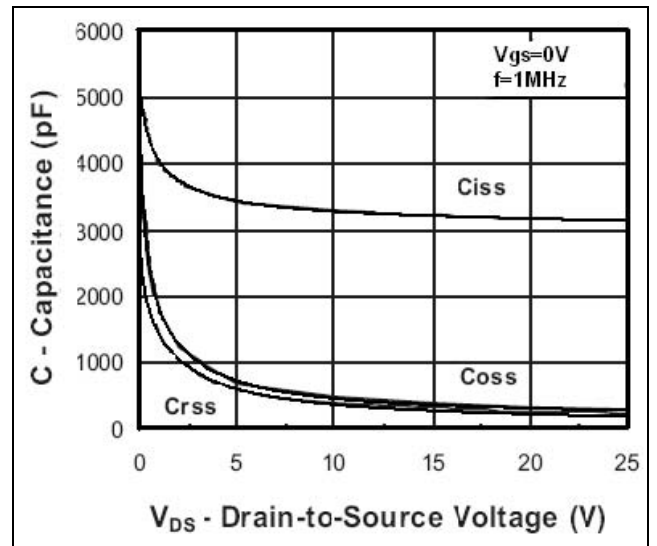

Capacitance

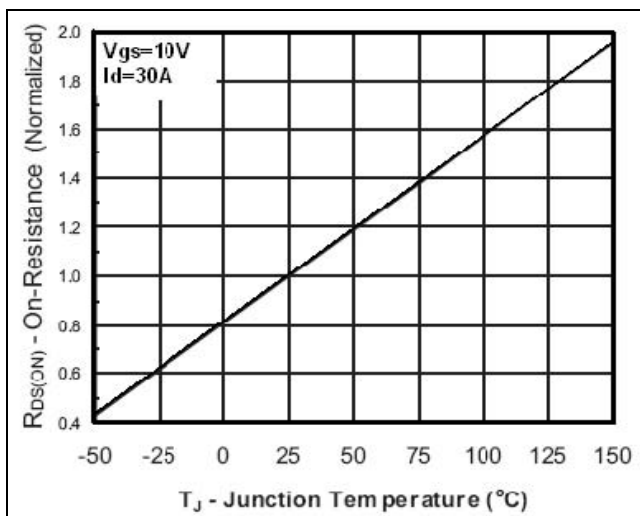

On Resistance vs. Junction Temperature

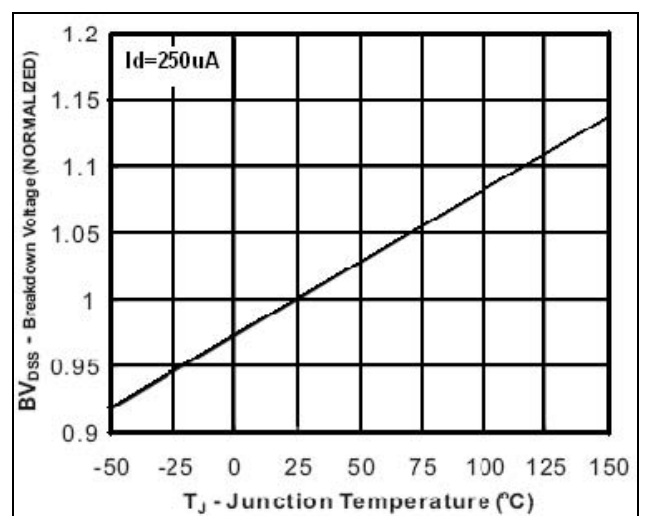

Breakdown Voltage vs. Junction Temperature

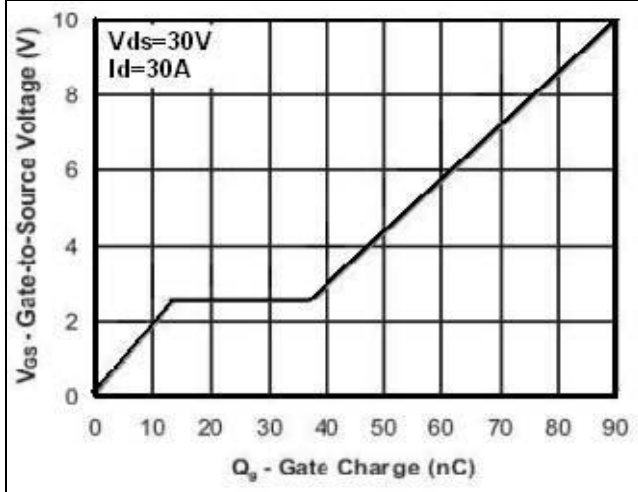

Gate Charge

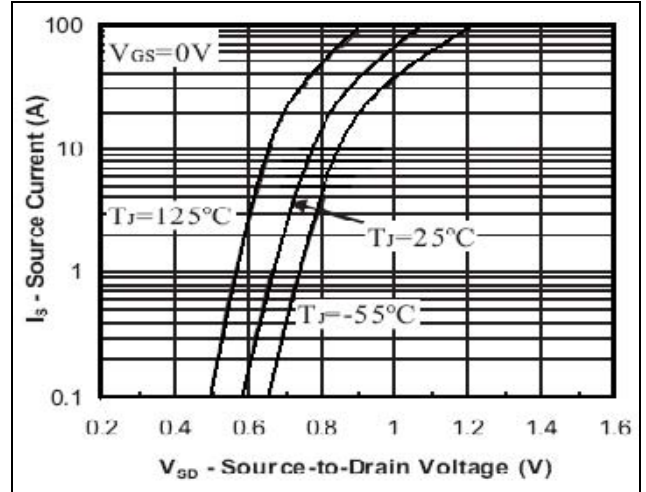

Source-Drain Diode Forward Voltage

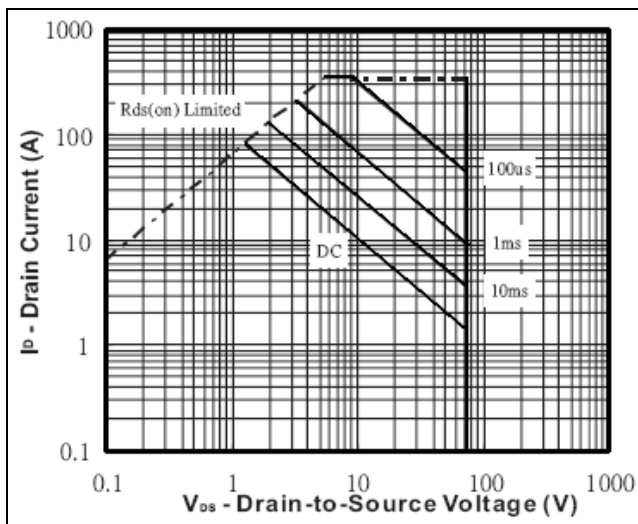

Safe Operation Area

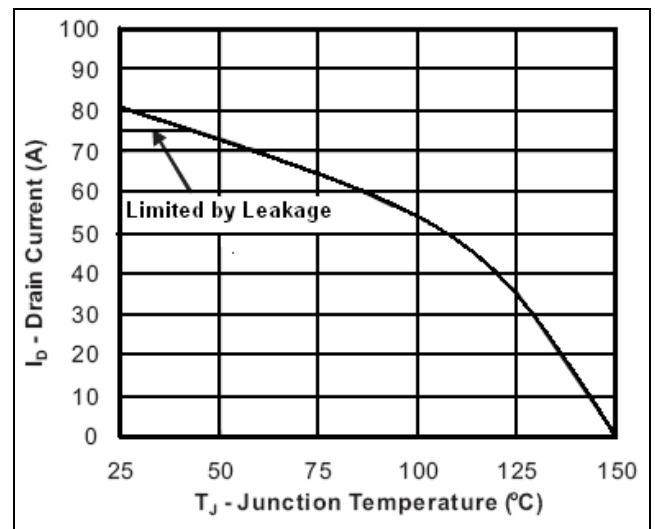

Max Drain Current vs. Junction

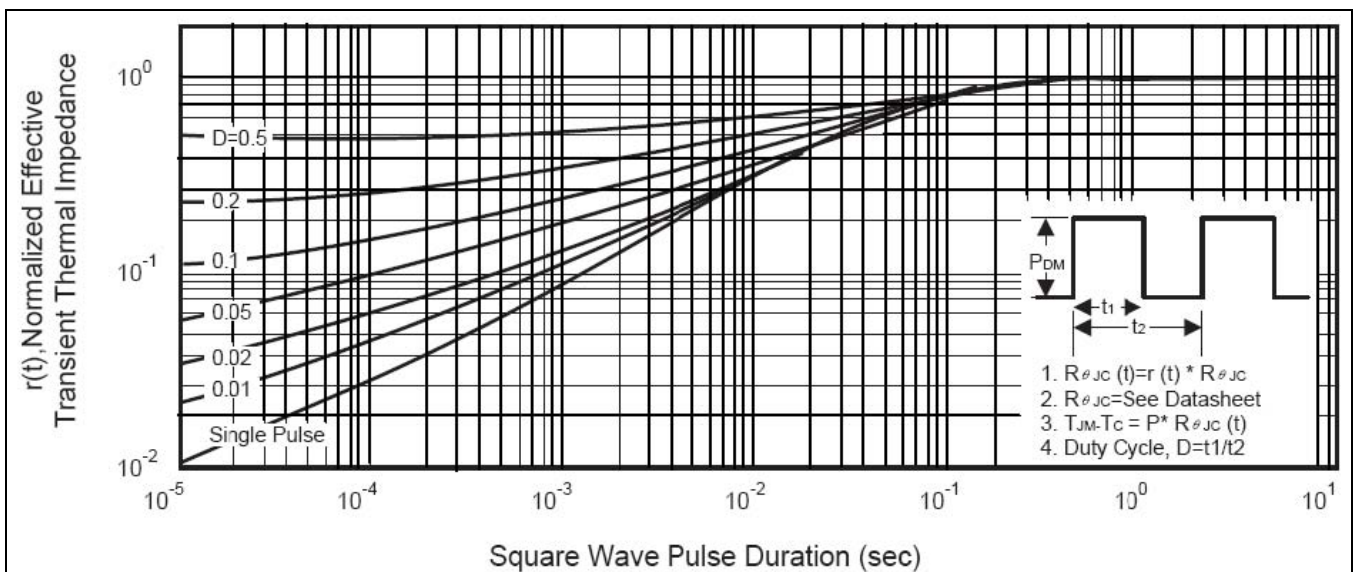

Transient Thermal Impedance Curve

TO-220 MECHANICAL DATA:

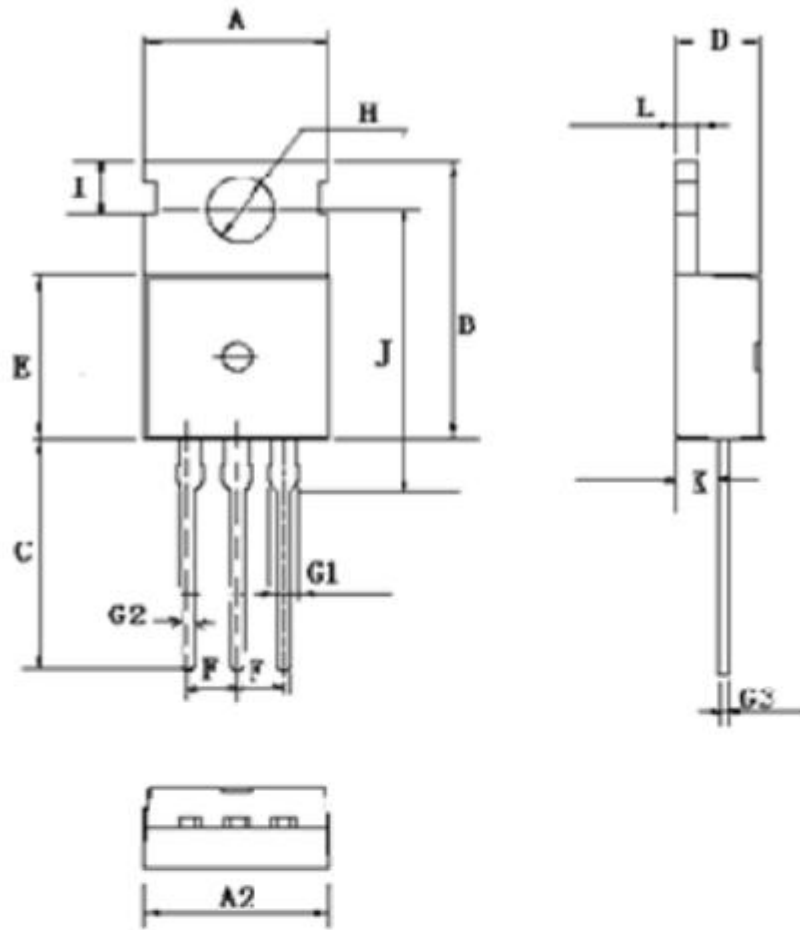

TO-220 3L

图形对应符号	产品外形尺寸
A(mm)	9.66~10.28
A2(mm)	9.80~10.20
B(mm)	15.6~15.8
C(mm)	12.70~14.27
D(mm)	4.30~4.70
E(mm)	8.59~9.40
F(mm)	2.54 (nom)
G1(mm)	1.42~1.62
G2(mm)	0.70~0.95
G3(mm)	0.45~0.60
H(mm) dia.	3.50~3.70
I(mm)	2.7~2.9
J(mm)	15.70~16.25
K(mm)	2.20~2.90
L(mm)	1.15~1.40
M(mm)	0.5