

**Features:**

- Advanced trench process technology
- Special designed for Convertors and power controls
- High density cell design for ultra low Rdson
- Fully characterized Avalanche voltage and current
- Avalanche Energy 100% test

**Description:**

The SSF3018 is a new generation of middle voltage and high current N-Channel enhancement mode trench power MOSFET. This new technology increases the cell density and reduces the on-resistance; its typical Rdson can reduce to 13.8mohm.

**Application:**

- Power switching application

**Absolute Maximum Ratings**

	Parameter	Max.	Units
$I_D@T_c=25^\circ\text{C}$	Continuous drain current, VGS@10V	60	A
$I_D@T_c=100^\circ\text{C}$	Continuous drain current, VGS@10V	50	
$I_{DM}$	Pulsed drain current ①	240	
$P_D@T_c=25^\circ\text{C}$	Power dissipation	147	W
	Linear derating factor	2.0	W/°C
$V_{GS}$	Gate-to-Source voltage	±20	V
$E_{AS}$	Single pulse avalanche energy ②	480	mJ
$E_{AR}$	Repetitive avalanche energy	TBD	
$T_J$ $T_{STG}$	Operating Junction and Storage Temperature Range	-55 to +150	°C

**ID=60A**  
**BV=100V**  
**Rdson=15mohm**

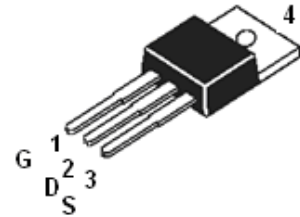
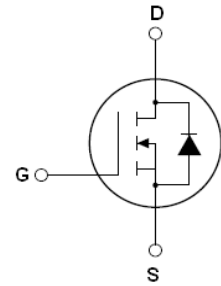
**SSF3018 TOP View (TO220)**
**Thermal Resistance**

	Parameter	Min.	Typ.	Max.	Units
$R_{\theta JC}$	Junction-to-case	—	0.85	—	°C/W

**Electrical Characteristics @TJ=25 °C(unless otherwise specified)**

	Parameter	Min.	Typ.	Max.	Units	Test Conditions
$BV_{DSS}$	Drain-to-Source breakdown voltage	100	—	—	V	$V_{GS}=0V, I_D=250\mu A$
$R_{DS(on)}$	Static Drain-to-Source on-resistance	—	13.8	15	mΩ	$V_{GS}=10V, I_D=30A$
$V_{GS(th)}$	Gate threshold voltage	2.0	—	4.0	V	$V_{DS}=V_{GS}, I_D=250\mu A$
$g_{fs}$	Forward transconductance	—	42	—	S	$V_{DS}=10V, I_D=30A$
$I_{DSS}$	Drain-to-Source leakage current	—	—	1	μA	$V_{DS}=100V, V_{GS}=0V$
		—	—	100		$V_{DS}=100V, V_{GS}=0V, T_J=150^\circ\text{C}$
$I_{GSS}$	Gate-to-Source forward leakage	—	—	100	nA	$V_{GS}=20V$
	Gate-to-Source reverse leakage	—	—	-100		$V_{GS}=-20V$
$Q_g$	Total gate charge	—	49	—	nC	$I_D=10A$
$Q_{gs}$	Gate-to-Source charge	—	15	—	nC	$V_{DS}=0.5V_{DSS}$

$Q_{gd}$	Gate-to-Drain("Miller") charge	—	11	—		$V_{GS}=10V$
$t_{d(on)}$	Turn-on delay time	—	27	—	nS	$V_{DS}=0.5V_{DSS}$ $I_D=10A$ $R_G=15\Omega$ $V_{GS}=10V$
$t_r$	Rise time	—	40	—		
$t_{d(off)}$	Turn-Off delay time	—	43	—		
$t_f$	Fall time	—	37	—		
$C_{iss}$	Input capacitance	—	2650	—	pF	$V_{GS}=0V$ $V_{DS}=25V$ $f=1.0MHZ$
$C_{oss}$	Output capacitance	—	335	—		
$C_{rss}$	Reverse transfer capacitance	—	60	—		

### Source-Drain Ratings and Characteristics

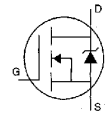
	Parameter	Min.	Typ.	Max.	Units	Test Conditions
$I_S$	Continuous Source Current. (Body Diode)	—	—	60	A	MOSFET symbol showing the integral reverse p-n junction diode. 
$I_{SM}$	Pulsed Source Current (Body Diode) ①	—	—	240		
$V_{SD}$	Diode Forward Voltage	—	—	1.3	V	$T_J=25^\circ C, I_S=30A, V_{GS}=0V$ ③
$t_{rr}$	Reverse Recovery Time	—	59	—	nS	$I_F=0.5 \cdot I_S, V_{GS}=0V, V_R=0.5 \cdot V_{DSS}$ $di/dt=100A/\mu s$ ③
$Q_{rr}$	Reverse Recovery Charge	—	112	—	nC	
$t_{on}$	Forward Turn-on Time	Intrinsic turn-on time is negligible (turn-on is dominated by $L_S + L_D$ )				

#### Notes:

- ① Repetitive rating; pulse width limited by max junction temperature.
- ② Test condition:  $L = 0.3mH, I_D = 37A, V_{DD} = 50V$
- ③ Pulse width  $\leq 300\mu s$ ; duty cycle  $\leq 1.5\%$   $R_G = 25\Omega$  Starting  $T_J = 25^\circ C$

#### EAS test circuits:

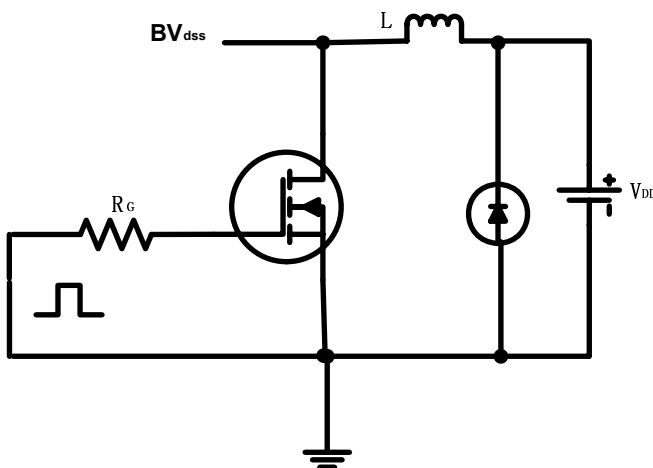

#### Gate charge test circuit:

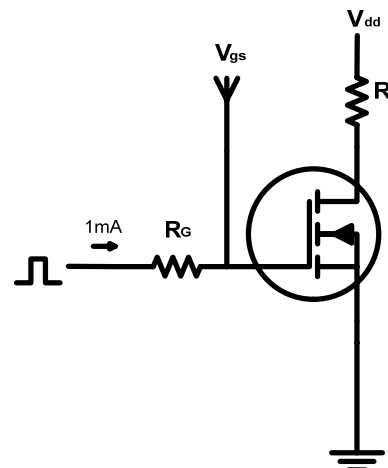

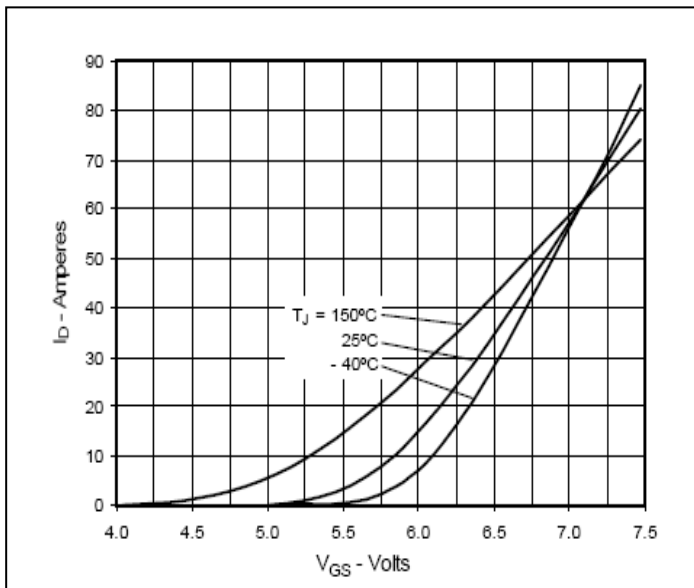
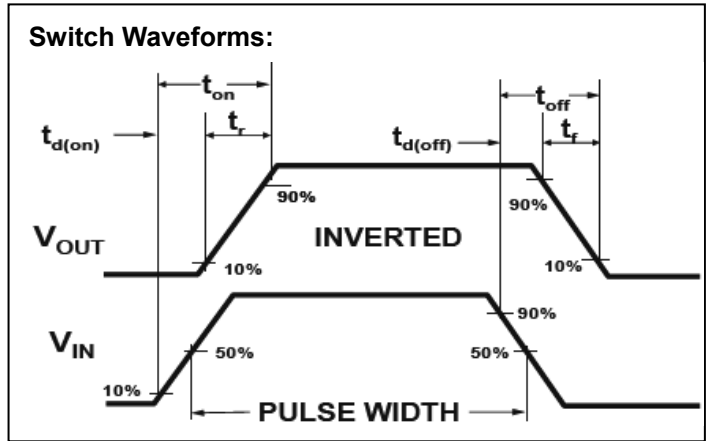
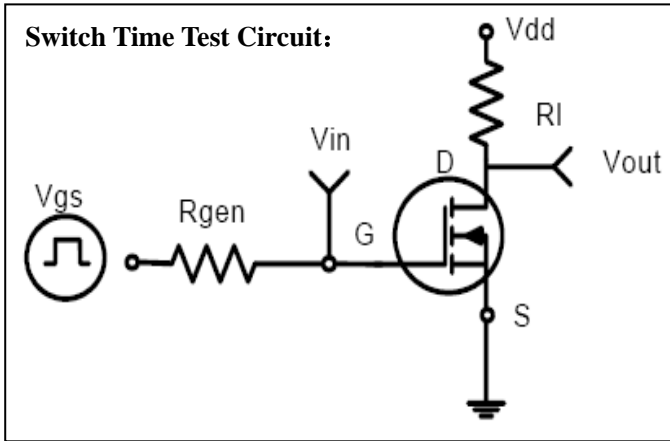

**Input Admittance**

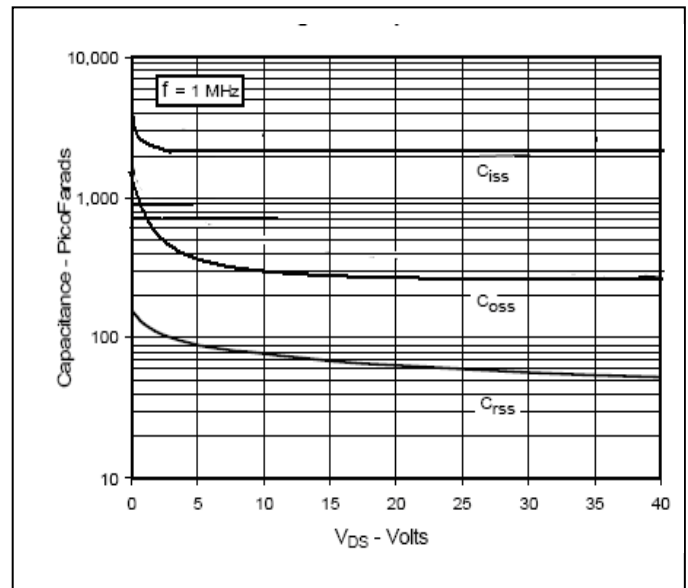

**Capacitance**

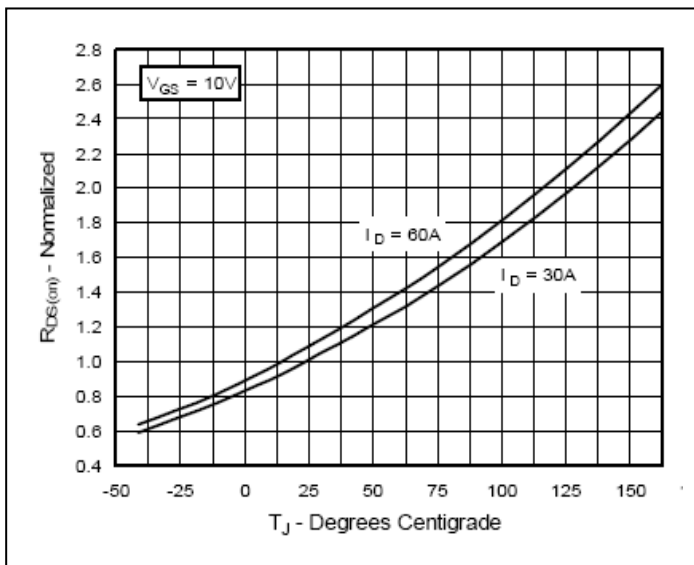

**On Resistance vs. Junction Temperature**

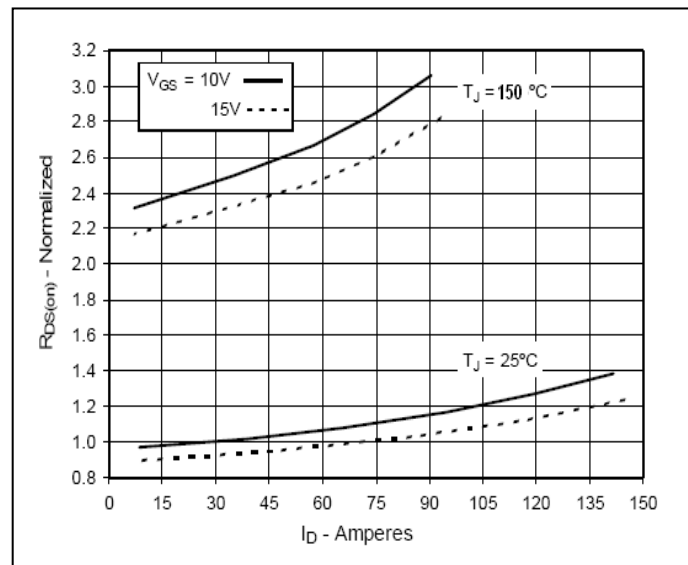

**On Resistance vs. Drain Current**

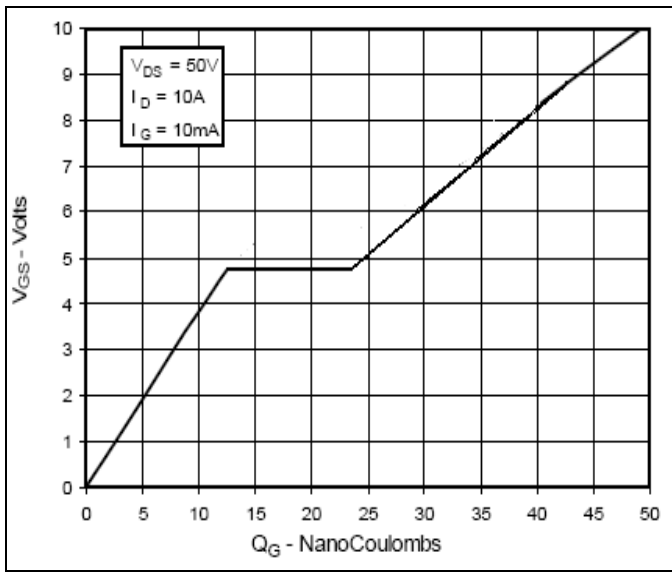

**Gate Charge**

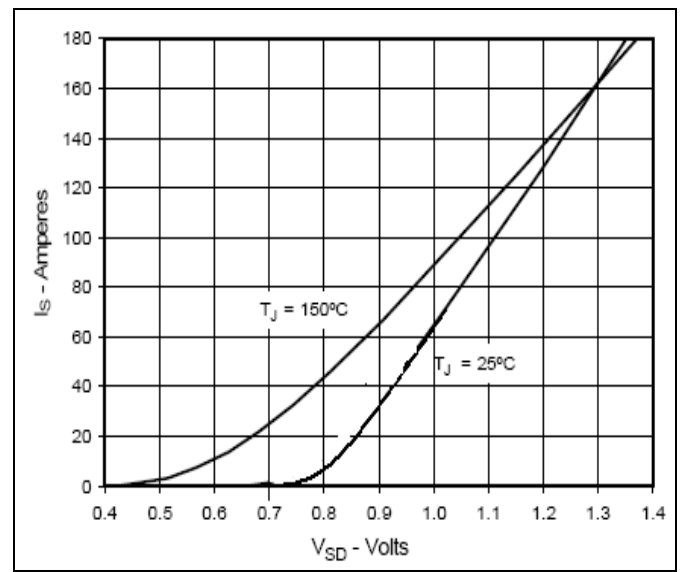

**Forward Voltage Drop of Intrinsic Diode**

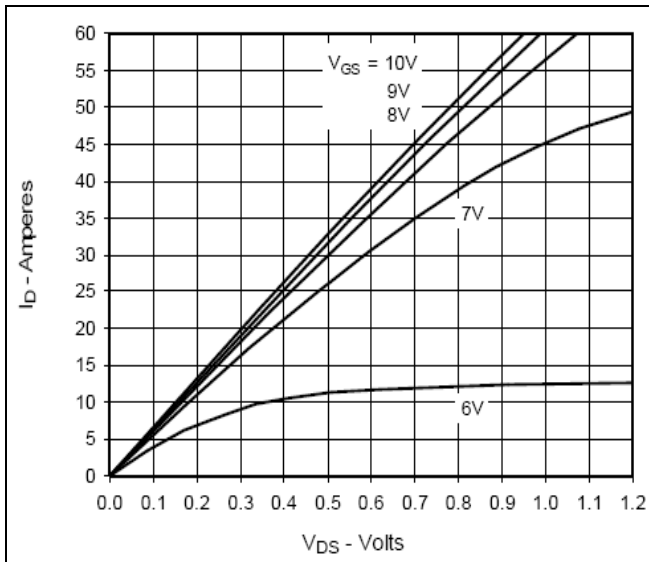

**Output Characteristics@25°C**

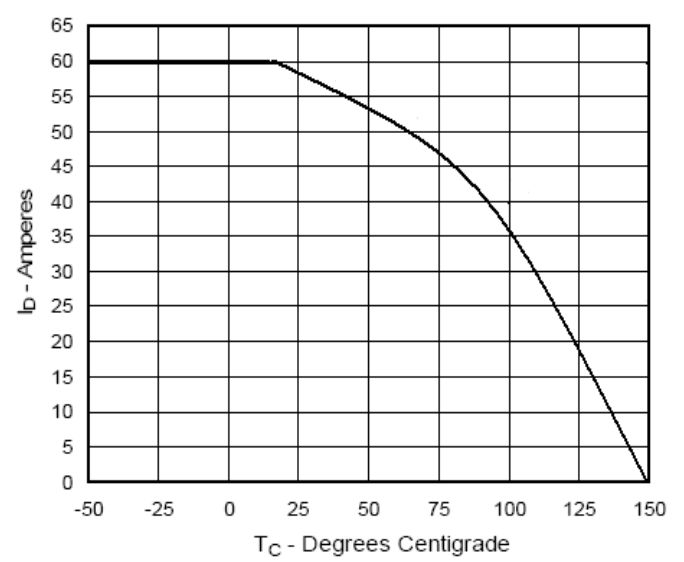

**Drain Current vs. Case Temperature**

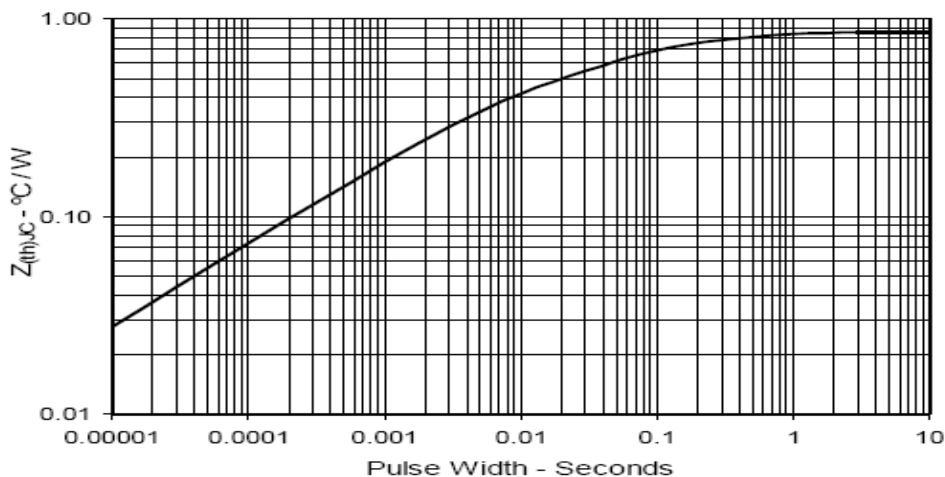

**Maximum Transient Thermal Impedance**

## TO220 MECHANICAL DATA:

