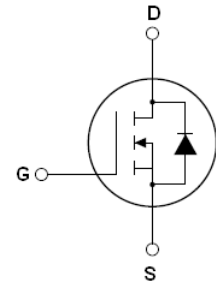

Features:

- Advanced trench process technology
- Ultra low $R_{ds(on)}$, typical 16mohm
- High avalanche energy, 100% test
- Fully characterized avalanche voltage and current

$I_D = 60A$
 $BV = 100V$
 $R_{ds(on)} = 16m\Omega$ (Typ.)

Description:

The SSF1020 is a new generation of middle voltage and high current N-Channel enhancement mode trench power MOSFET. This new technology increases the device reliability and electrical parameter repeatability. SSF1020 is assembled in high reliability and qualified assembly house.

Application:

- Power switching application

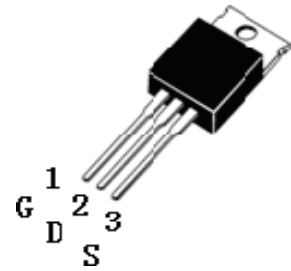

SSF1020 TOP View (TO220)

Absolute Maximum Ratings

	Parameter	Max.	Units
$I_D @ T_c = 25^\circ C$	Continuous drain current, $V_{GS} @ 10V$	60	A
$I_D @ T_c = 100^\circ C$	Continuous drain current, $V_{GS} @ 10V$	50	
I_{DM}	Pulsed drain current ①	240	
$P_D @ T_c = 25^\circ C$	Power dissipation	180	W
	Linear derating factor	2.0	W/C
V_{GS}	Gate-to-Source voltage	± 20	V
E_{AS}	Single pulse avalanche energy ②	240	mJ
E_{AR}	Repetitive avalanche energy	TBD	
T_J T_{STG}	Operating Junction and Storage Temperature Range	-55 to +175	$^\circ C$

Thermal Resistance

	Parameter	Min.	Typ.	Max.	Units
$R_{\theta JC}$	Junction-to-case	—	0.83	—	$^\circ C/W$
$R_{\theta JA}$	Junction-to-ambient	—	—	62	

Electrical Characteristics @ $T_J = 25^\circ C$ (unless otherwise specified)

	Parameter	Min.	Typ.	Max.	Units	Test Conditions
BV_{DSS}	Drain-to-Source breakdown voltage	100	—	—	V	$V_{GS} = 0V, I_D = 250\mu A$
$R_{DS(on)}$	Static Drain-to-Source on-resistance	—	16	20	m Ω	$V_{GS} = 10V, I_D = 30A$
$V_{GS(th)}$	Gate threshold voltage	2.0	3.0	4.0	V	$V_{DS} = V_{GS}, I_D = 250\mu A$
g_{fs}	Forward transconductance	—	58	—	S	$V_{DS} = 5V, I_D = 30A$
I_{DSS}	Drain-to-Source leakage current	—	—	1	μA	$V_{DS} = 100V, V_{GS} = 0V$
		—	—	10		$V_{DS} = 100V, V_{GS} = 0V, T_J = 150^\circ C$

I_{GSS}	Gate-to-Source forward leakage	—	—	100	nA	$V_{GS}=20V$
	Gate-to-Source reverse leakage	—	—	-100		$V_{GS}=-20V$
Q_g	Total gate charge	—	90	—	nC	$I_D=30A$
Q_{gs}	Gate-to-Source charge	—	14	—		$V_{DD}=30V$
Q_{gd}	Gate-to-Drain("Miller") charge	—	24	—		$V_{GS}=10V$
$t_{d(on)}$	Turn-on delay time	—	18.2	—	nS	$V_{DD}=30V$
t_r	Rise time	—	15.6	—		$I_D=2A, R_L=15\Omega$
$t_{d(off)}$	Turn-Off delay time	—	70.5	—		$R_G=2.5\Omega$
t_f	Fall time	—	13.8	—		$V_{GS}=10V$
C_{iss}	Input capacitance	—	3150	—	pF	$V_{GS}=0V$
C_{oss}	Output capacitance	—	300	—		$V_{DS}=25V$
C_{rss}	Reverse transfer capacitance	—	240	—		$f=1.0MHz$

Source-Drain Ratings and Characteristics

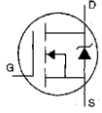
	Parameter	Min.	Typ.	Max.	Units	Test Conditions
I_S	Continuous Source Current (Body Diode)	—	—	60	A	MOSFET symbol showing the integral reverse p-n junction diode. 
I_{SM}	Pulsed Source Current (Body Diode) ①	—	—	240		
V_{SD}	Diode Forward Voltage	—	—	1.3	V	$T_J=25C, I_S=30A, V_{GS}=0V$ ③
t_{rr}	Reverse Recovery Time	—	57	—	nS	$T_J=25C, I_F=60A$ $di/dt=100A/\mu s$ ③
Q_{rr}	Reverse Recovery Charge	—	107	—	nC	
t_{on}	Forward Turn-on Time	Intrinsic turn-on time is negligible (turn-on is dominated by $L_S + L_D$)				

Notes:

- ① Repetitive rating; pulse width limited by max junction temperature.
- ② Test condition: $L = 0.3mH, I_D = 40A, V_{DD} = 50V$
- ③ Pulse width $\leq 300\mu s$, duty cycle $\leq 1.5\%$; $R_G = 25\Omega$ Starting $T_J = 25^\circ C$

EAS test circuit

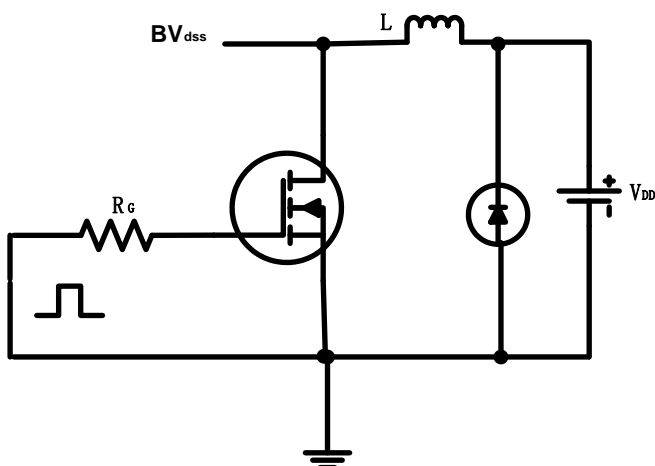

Gate charge test circuit

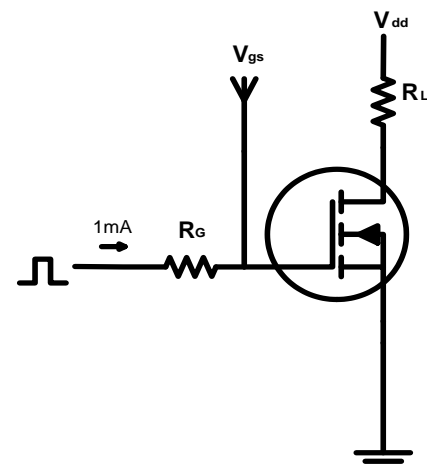

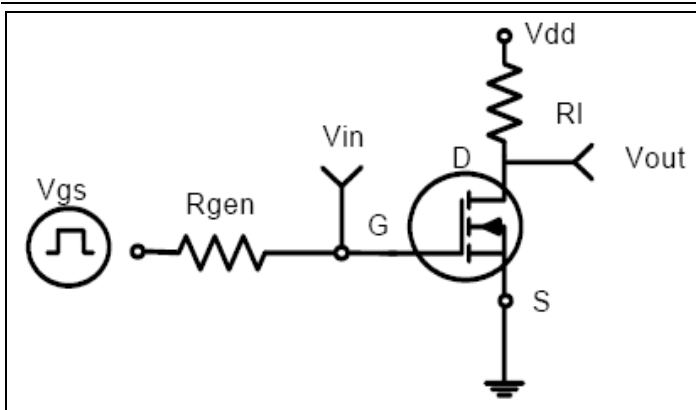

Switch Time Test Circuit:

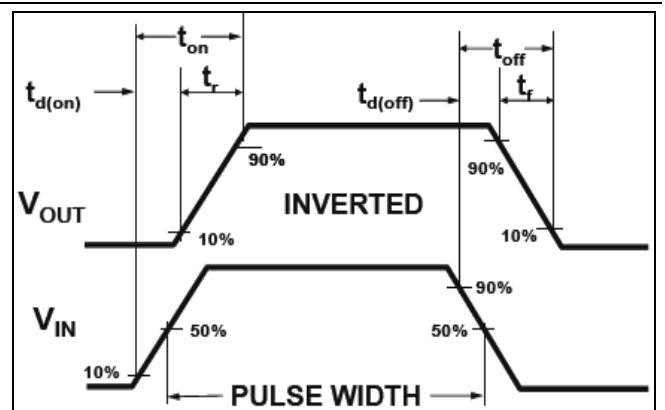

Switch Waveforms:

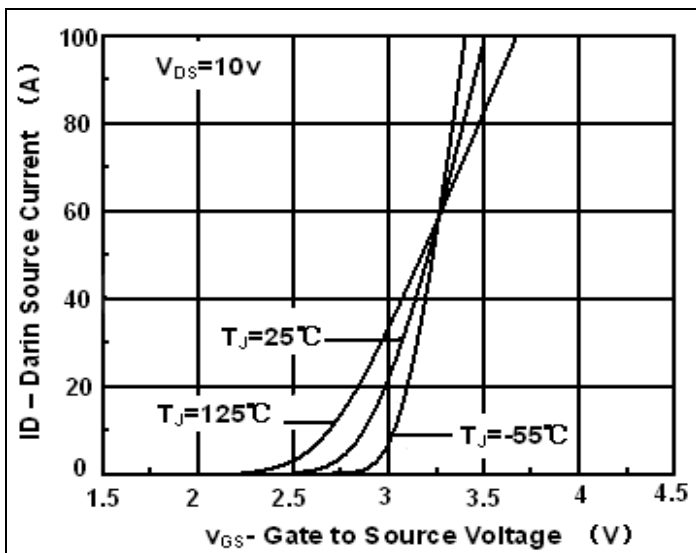

Transfer Characteristic

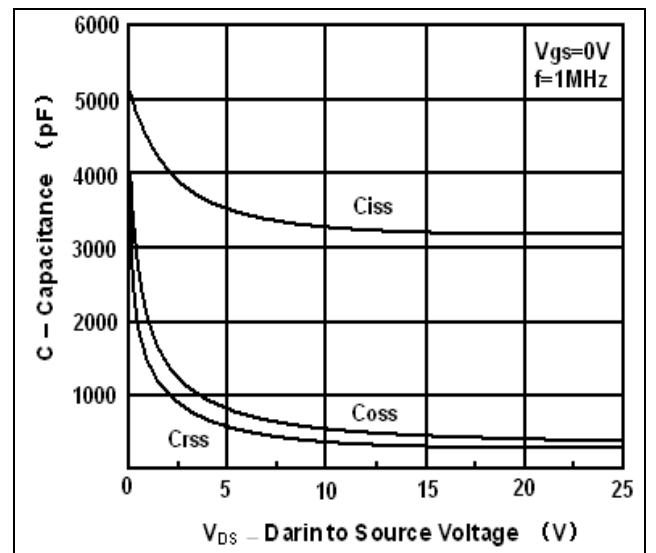

Capacitance

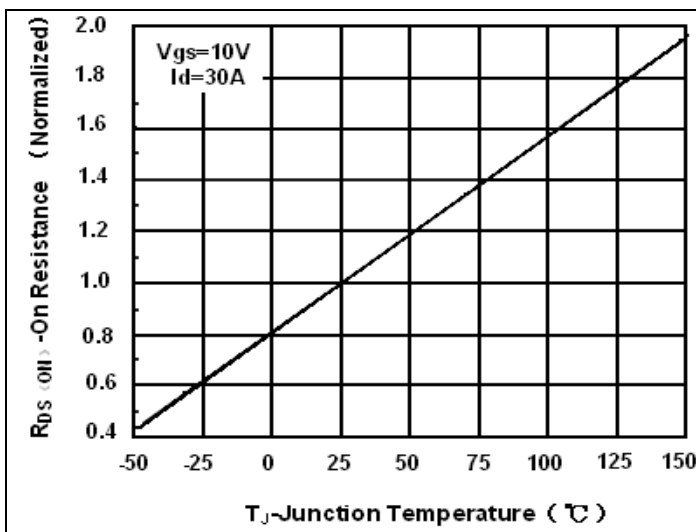

On Resistance vs. Junction Temperature

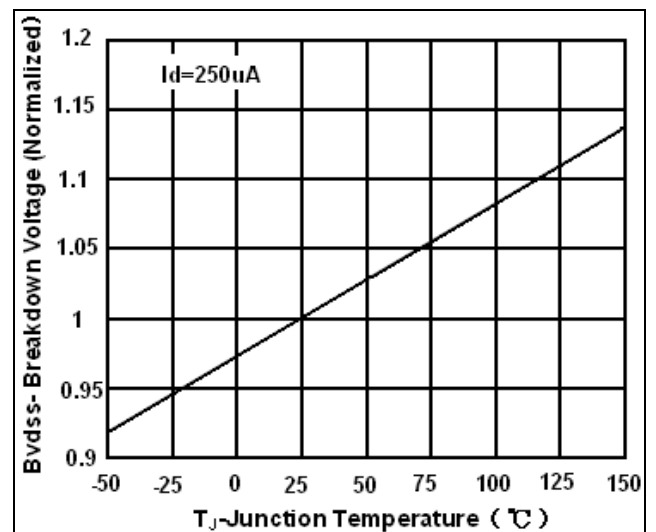

Breakdown Voltage vs. Junction Temperature

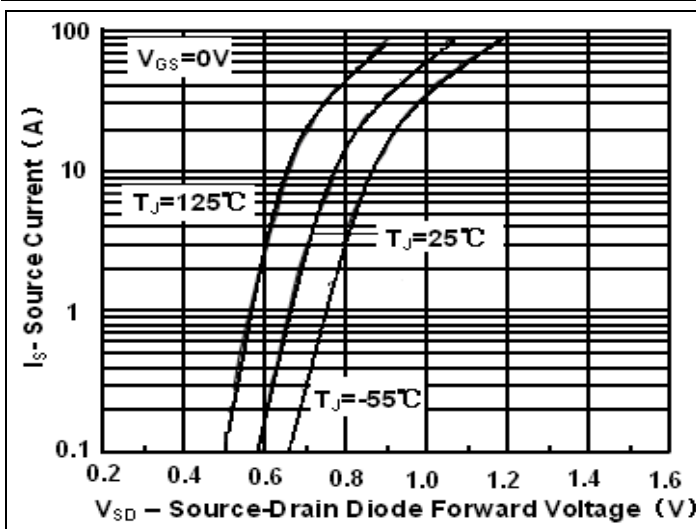

Source-Drain Diode Forward Voltage

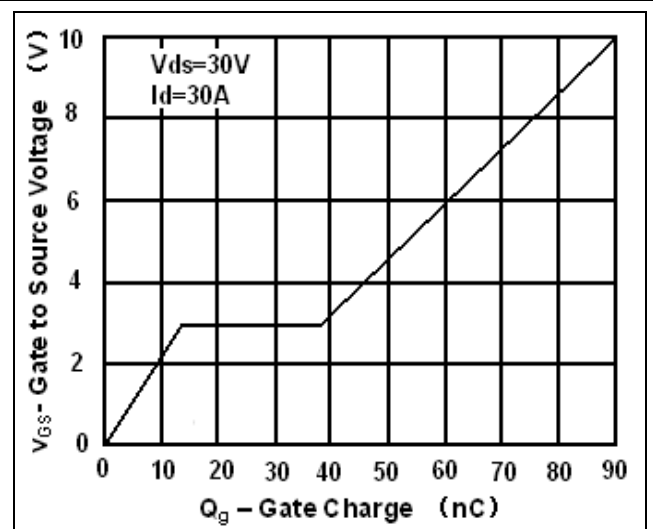

Gate Charge

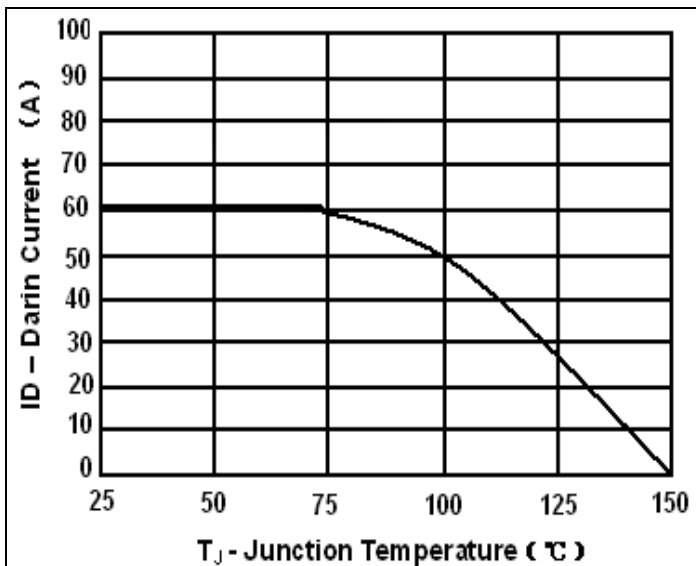

Max Drain Current vs. Junction Temperature

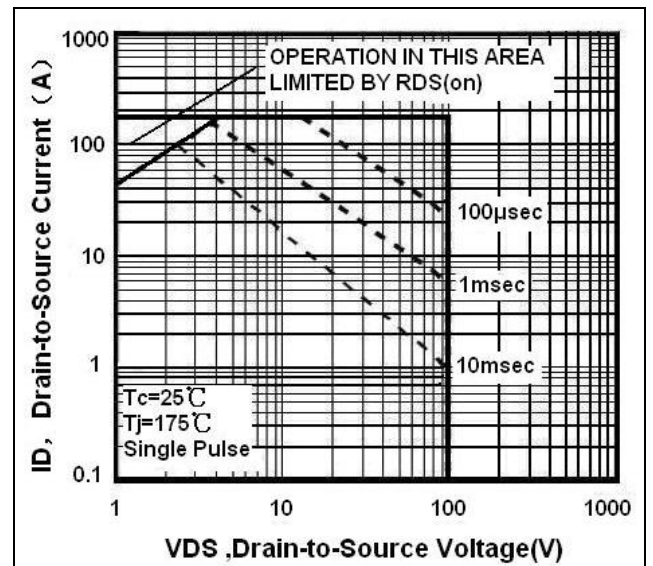

Safe Operation Area

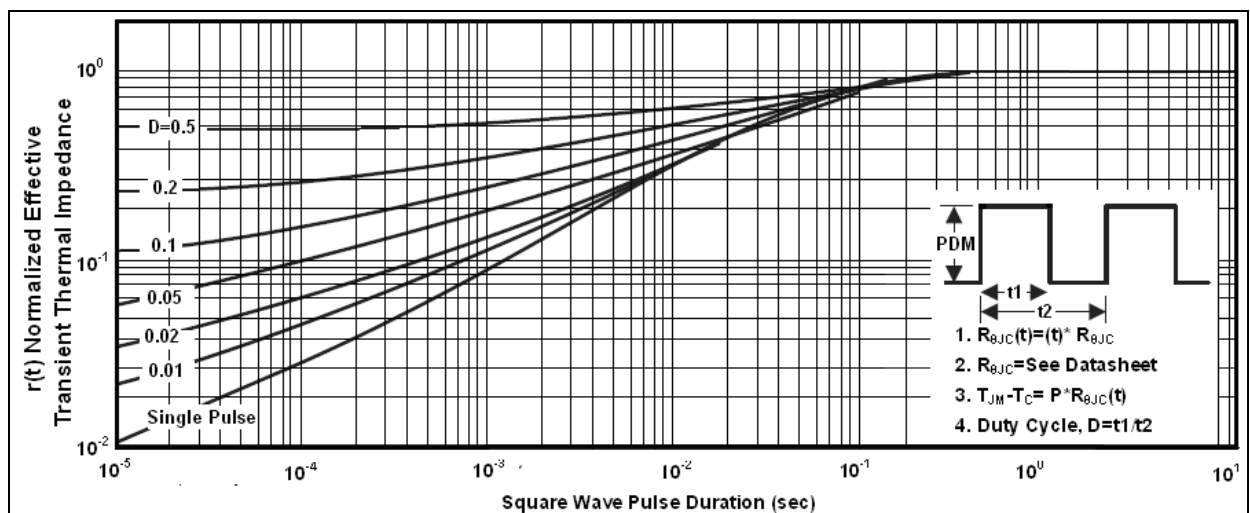

Transient Thermal Impedance Curve

TO220 MECHANICAL DATA:

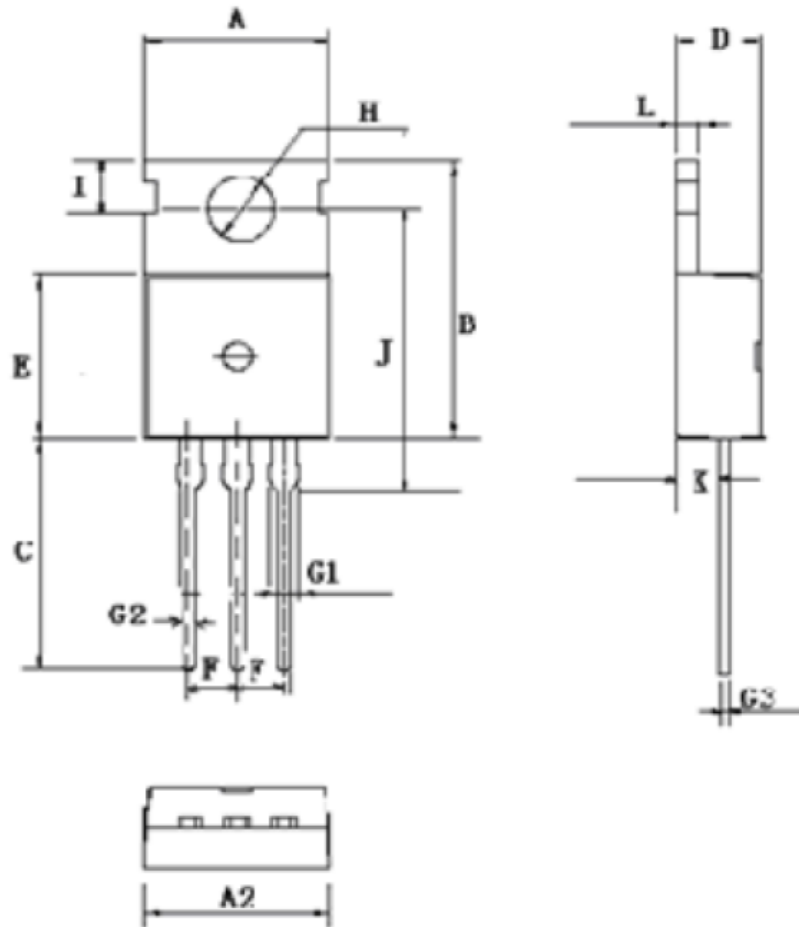

TO-220 3L

图形对应符号	产品外形尺寸
A(mm)	9.66~10.28
A2(mm)	9.80~10.20
B(mm)	15.6~15.8
C(mm)	12.70~14.27
D(mm)	4.30~4.70
E(mm)	8.59~9.40
F(mm)	2.54 (nom)
G1(mm)	1.42~1.62
G2(mm)	0.70~0.95
G3(mm)	0.45~0.60
H(mm) dia.	3.50~3.70
I(mm)	2.7~2.9
J(mm)	15.70~16.25
K(mm)	2.20~2.90
L(mm)	1.15~1.40
M(mm)	0.5