

C2611(NPN)

TO-126 Transistor

TO-126

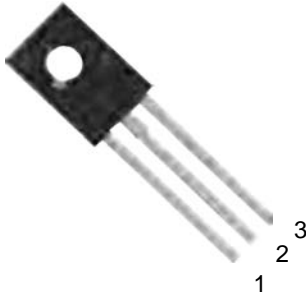

1. EMITTER
2. COLLECTOR
3. BASE

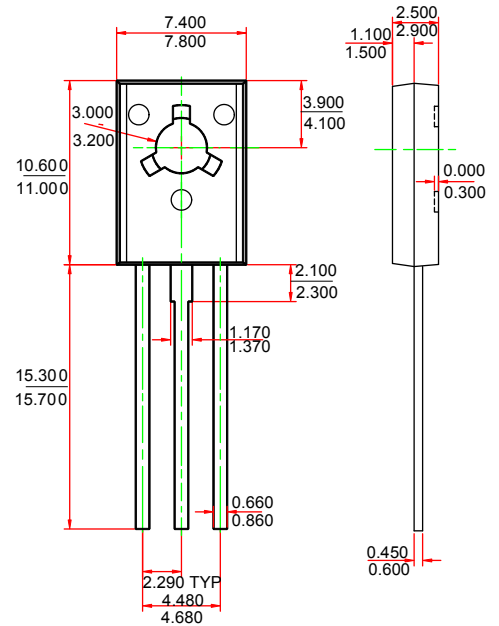

Dimensions in inches and (millimeters)

Features

- ✧ power switching applications

MAXIMUM RATINGS ($T_A=25^\circ\text{C}$ unless otherwise noted)

Symbol	Parameter	Value	Units
V_{CB0}	Collector -Base Voltage	600	V
V_{CE0}	Collector-Emitter Voltage	400	V
V_{EB0}	Emitter-Base Voltage	7	V
I_C	Collector Current -Continuous	0.2	A
P_C	Collector Power Dissipation	1	W
T_J	Junction Temperature	150	$^\circ\text{C}$
T_{stg}	Storage Temperature	-55-150	$^\circ\text{C}$

ELECTRICAL CHARACTERISTICS ($T_{amb}=25^\circ\text{C}$ unless otherwise specified)

Parameter	Symbol	Test conditions	MIN	TYP	MAX	UNIT
Collector-base breakdown voltage	$V_{(BR)CBO}$	$I_C=100\mu\text{A}, I_E=0$	600			V
Collector-emitter breakdown voltage	$V_{(BR)CEO}$	$I_C=1\text{mA}, I_B=0$	400			V
Emitter-base breakdown voltage	$V_{(BR)EBO}$	$I_E=100\mu\text{A}, I_C=0$	7			V
Collector cut-off current	I_{CBO}	$V_{CB}=600\text{V}, I_E=0$			100	μA
Collector cut-off current	I_{CEO}	$V_{CE}=400\text{V}, I_B=0$			200	μA
Emitter cut-off current	I_{EBO}	$V_{EB}=7\text{V}, I_C=0$			100	μA
DC current gain	$h_{FE(1)}$	$V_{CE}=20\text{V}, I_C=20\text{mA}$	10		40	
	$h_{FE(2)}$	$V_{CE}=10\text{V}, I_C=0.25\text{mA}$	5			
Collector-emitter saturation voltage	$V_{CE(sat)}$	$I_C=50\text{mA}, I_B=10\text{mA}$			0.5	V
		$I_C=100\text{mA}, I_B=20\text{mA}$			0.6	V
Base-emitter saturation voltage	$V_{BE(sat)}$	$I_C=50\text{mA}, I_B=10\text{mA}$			1.2	V
Transition frequency	f_T	$V_{CE}=20\text{V}, I_C=20\text{mA}$ $f=1\text{MHz}$	8			MHz
Fall time	t_s	$I_C=50\text{mA}$			0.3	μs
Storage time	t_f	$I_{B1}=-I_{B2}=5\text{mA}$ $V_{CC}=45\text{V}$			1.5	μs

CLASSIFICATION OF $h_{FE(1)}$

Rank						
Range	10-15	15-20	20-25	25-30	30-35	35-40

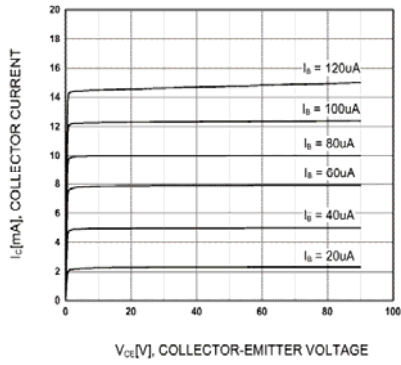
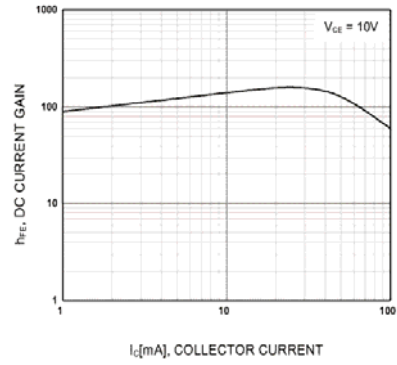
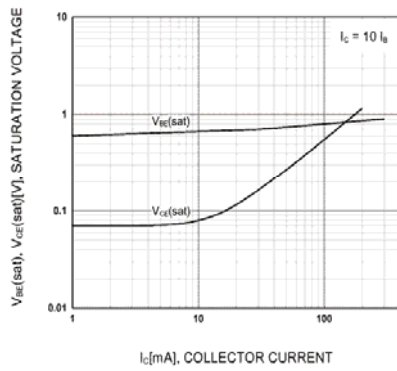
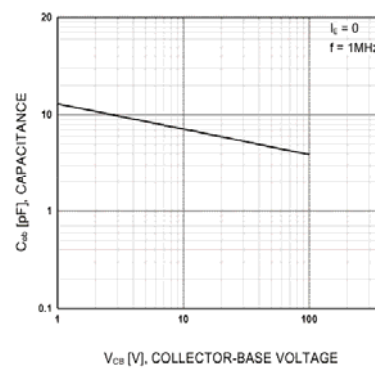
Typical Characteristics

Figure 1. Static Characteristic

Figure 2. DC current Gain

**Figure 3. Base-Emitter Saturation Voltage
Collector-Emitter Saturation Voltage**

Figure 4. Collector Output Capacitance