



VOLTAGE RANGE: 600 ---1000 V
CURRENT: 1.5 A

Features

- ◇ Low cost
- ◇ Diffused junction
- ◇ Low leakage
- ◇ Low forward voltage drop
- ◇ High current capability
- ◇ Easily cleaned with Freon, Alcohol, Isopropanol and similar solvents
- ◇ The plastic material carries U/L recognition 94V-0

Mechanical Data

- ◇ Case: JEDEC DO-15, molded plastic
- ◇ Terminals: Axial lead, solderable per MIL-STD-202, Method 208
- ◇ Polarity: Color band denotes cathode
- ◇ Weight: 0.014 ounces, 0.39 grams
- ◇ Mounting position: Any

DO - 15

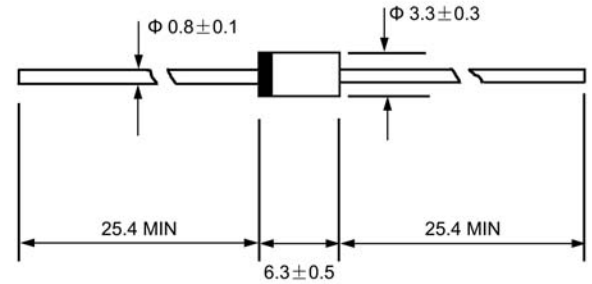

Dimensions in millimeters

MAXIMUM RATINGS AND ELECTRICAL CHARACTERISTICS

Ratings at 25°C ambient temperature unless otherwise specified.

Single phase, half wave, 60 Hz, resistive or inductive load. For capacitive load, derate by 20%.

		TVR4J	TVR4N	UNITS
Maximum recurrent peak reverse voltage	V_{RRM}	600	1000	V
Maximum RMS voltage	V_{RMS}	420	700	V
Maximum DC blocking voltage	V_{DC}	600	1000	V
Maximum average forward rectified current 9.5mm lead length, @ $T_A=75^\circ\text{C}$	$I_{F(AV)}$	1.5		A
Peak forward surge current 8.3ms single half-sine-wave superimposed on rated load	I_{FSM}	50.0		A
Maximum instantaneous forward voltage @ 1.5 A	V_F	1.3		V
Maximum reverse current @ $T_A=25^\circ\text{C}$ at rated DC blocking voltage @ $T_A=100^\circ\text{C}$	I_R	5.0 100.0		μA
Maximum reverse recovery time (Note1)	t_{rr}	1000		ns
Typical junction capacitance (Note2)	C_J	20		pF
Typical thermal resistance (Note3)	$R_{\theta JA}$	40		$^\circ\text{C/W}$
Operating junction temperature range	T_J	-55-----150		$^\circ\text{C}$
Storage temperature range	T_{STG}	-55-----150		$^\circ\text{C}$

NOTE: 1. Measured with $I_F=0.5\text{A}$, $I_R=1\text{A}$, $I_L=0.25\text{A}$.

3. Thermal resistance from junction to ambient.

2. Measured at 1.0MHz and applied reverse voltage of 4.0V DC.

Ratings AND Characteristic Curves

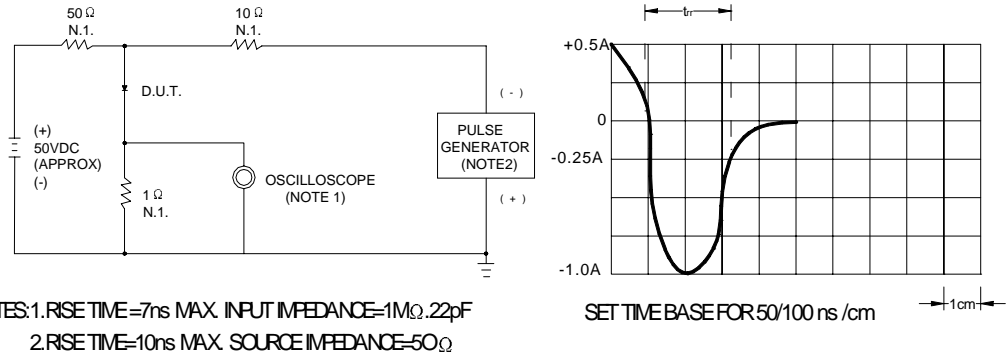
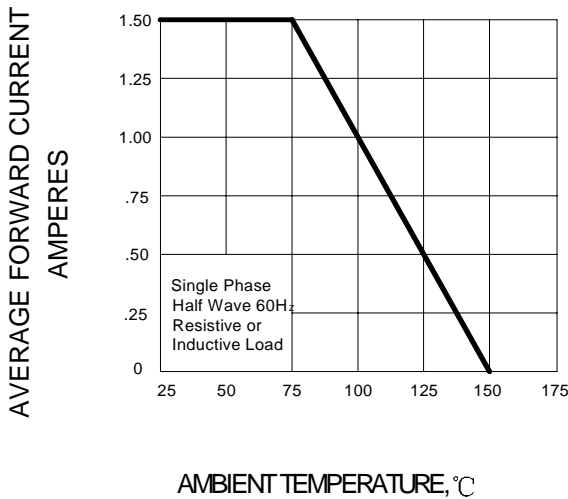
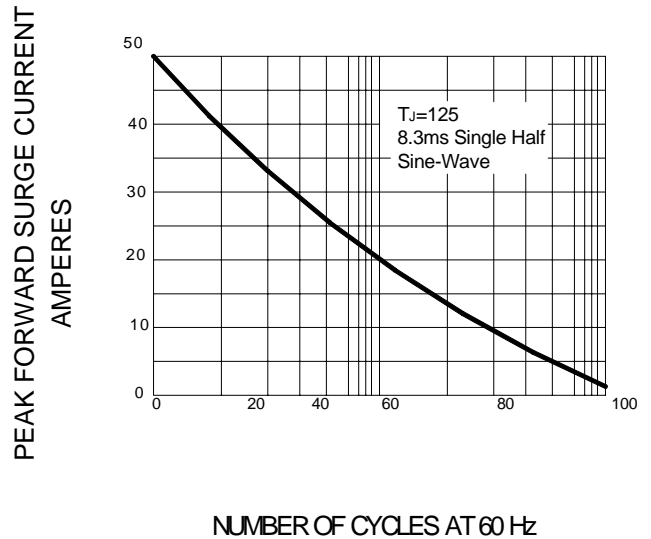
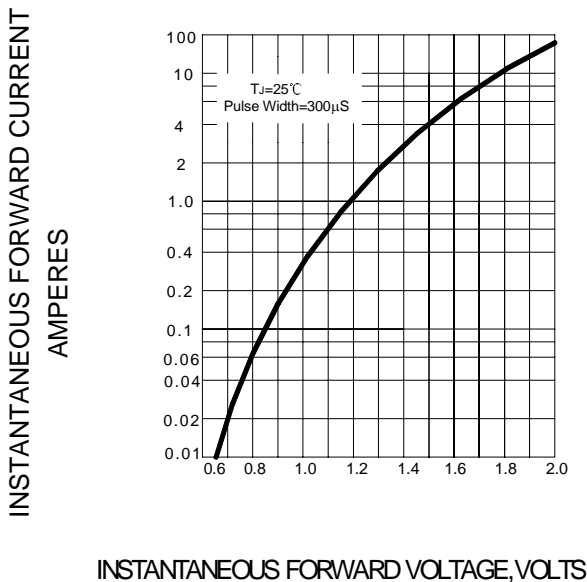
FIG.1 – REVERSE RECOVERY TIME CHARACTERISTIC AND TEST CIRCUIT DIAGRAM

FIG.2 – FORWARD DERATING CURVE

FIG.3 – PEAK FORWARD SURGE CURRENT

FIG.4 – TYPICAL FORWARD CHARACTERISTIC

FIG.5 – TYPICAL JUNCTION CAPACITANCE
