

ERD09-13--ERD09-15

Fast Recovery Rectifiers

VOLTAGE RANGE: 1300 --- 1500 V

CURRENT: 3.0 A



Features

- ◇ Low cost
- ◇ Diffused junction
- ◇ Low leakage
- ◇ Low forward voltage drop
- ◇ High current capability
- ◇ Easily cleaned with Freon, Alcohol, Isopropanol and similar solvents
- ◇ The plastic material carries U/L recognition 94V-0

Mechanical Data

- ◇ Case: JEDEC DO-27, molded plastic
- ◇ Polarity: Color band denotes cathode
- ◇ Weight: 0.041 ounces, 1.15 grams
- ◇ Mounting position: Any

DO - 27

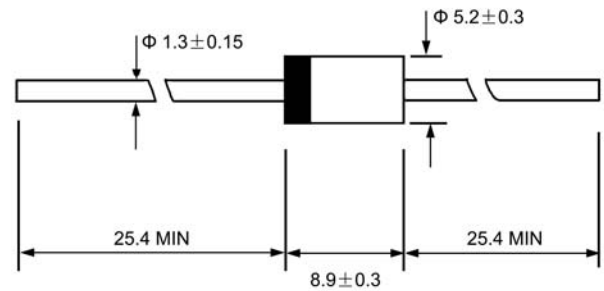

Dimensions in millimeters

MAXIMUM RATINGS AND ELECTRICAL CHARACTERISTICS

Ratings at 25°C ambient temperature unless otherwise specified.

Single phase, half wave, 60 Hz, resistive or inductive load. For capacitive load, derate by 20%.

		ERD09 -13	ERD09 -15	UNITS
Maximum recurrent peak reverse voltage	V_{RRM}	1300	1500	V
Maximum RMS voltage	V_{RMS}	910	1050	V
Maximum DC blocking voltage	V_{DC}	1300	1500	V
Maximum average forward rectified current 9.5mm lead length, @ $T_A=75^\circ\text{C}$	$I_{F(AV)}$	3.0		A
Peak forward surge current 8.3ms single half-sine-wave superimposed on rated load @ $T_J=125^\circ\text{C}$	I_{FSM}	70.0		A
Maximum instantaneous forward voltage at 3.0 A	V_F	1.5		V
Maximum reverse current @ $T_A=25^\circ\text{C}$ at rated DC blocking voltage @ $T_A=100^\circ\text{C}$	I_R	10.0	200.0	μA
Maximum reverse recovery time (Note1)	t_{rr}	600		ns
Typical junction capacitance (Note2)	C_J	32		pF
Typical thermal resistance (Note3)	$R_{\theta JA}$	22		$^\circ\text{C/W}$
Operating junction temperature range	T_J	-55----+150		$^\circ\text{C}$
Storage temperature range	T_{STG}	-55----+150		$^\circ\text{C}$

NOTE:1. Measured with $I_F=0.5\text{A}$, $I_R=1\text{A}$, $I_{rr}=0.25\text{A}$.

2. Measured at 1.0MHz and applied reverse voltage of 4.0V DC.

3. Thermal resistance from junction to ambient.

Ratings AND Characteristic Curves

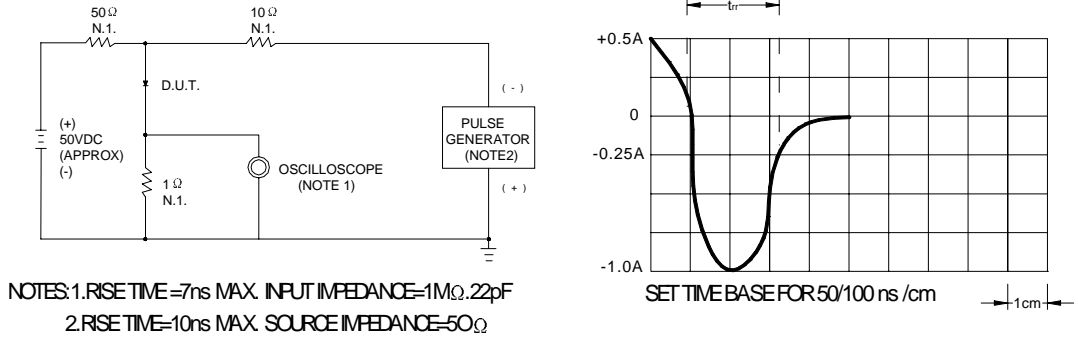
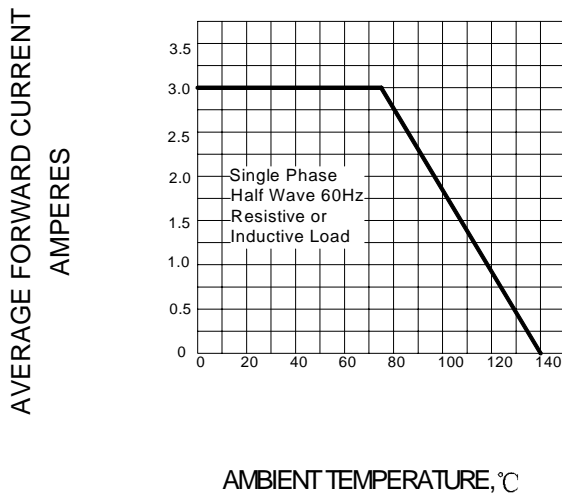
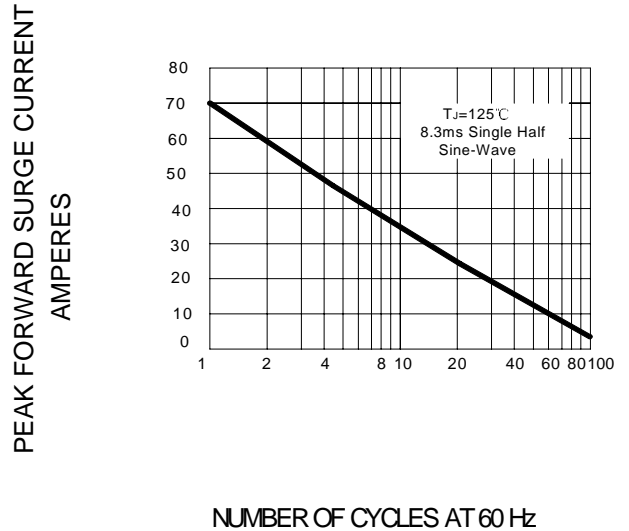
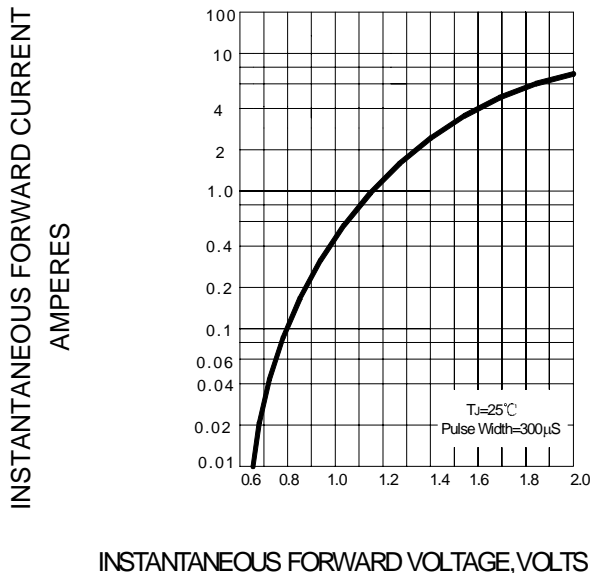
FIG.1 – REVERSE RECOVERY TIME CHARACTERISTIC AND TEST CIRCUIT DIAGRAM

FIG.2 – FORWARD DERATING CURVE

FIG.3 – PEAK FORWARD SURGE CURRENT

FIG.4 – TYPICAL FORWARD CHARACTERISTIC

FIG.5 – TYPICAL JUNCTION CAPACITANCE
