

**特征 FEATURES**

- .低成本. Low cost
- .正向压降低. Low forward voltage drop
- .低漏电. Low leakage current
- .高浪涌承受能力. High surge current capability
- .设计应用于机动车上. Designed for automotive applications

**机械数据 MECHANICAL DATA**

.端子:镀金端子,焊接按照 MIL-STD-202,方法 208.

Terminals: Plated terminals, solderable per  
MIL-STD-202, method 208.

.极性:红色代表阴极,黑色代表阳极引线.

Polarity :Red color denotes cathode

Black color denotes anode lead

.安装:结合与散热片. Mounting position: Wed with heat sink

.重量 : 11.2克. Weight: 11.2grams

**极限值和电参数** TA= 25℃除非另有规定. 单相,正半弦波,60HZ,阻抗或电感负载.为电容装载,减少电流的 20%

**MAXIMUM RATINGS AND ELECTRICAL CHARACTERISTICS**

Rating at 25℃ Ambient temp. Unless otherwise specified. Single phase, half sine wave, 60HZ, resistive or inductive load.

For capacitive load, derate current by 20%

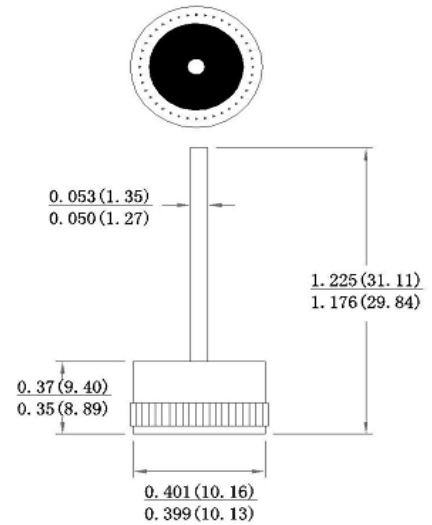
**MR**

Dimension in inch(millimeters)

	SYMBOL	MR							UNITS
		2501	2502	2503	2504	2505	2506	2507	
		N/P							
最大峰值反向电压 Maximum Current Peak Reverse Voltage	VRRM	50	100	200	400	600	800	1000	Volts
最大反向有效电压 Maximum RMS Voltage	VRMS	35	70	140	280	480	560	700	Volts
最大直流阻断电压 Maximum DC Blocking Voltage	VDC	50	100	200	400	600	800	1000	Volts
最大正向平均整流电流 $T_L=125^{\circ}\text{C}$ Maximum Average Forward Rectified Current	I(AV)	25							Amps
正向峰值浪涌电流 Peak Forward Surge Current 8.3ms Single Sine-wave on Rated Load (JEDEC Method)	IFSM	300							Amps
25A 直流电时最大正向瞬间电压降 Maximum Instantaneous Forward Voltage Drop at 25A DC	VF	1.0							Volts
最大反向漏电流 Maximum DC Reverse Current $T_A=25^{\circ}\text{C}$ at Rated DC Blocking Voltage $T_A=100^{\circ}\text{C}$	IR	5 500							uA
典型结电容 Typical Junction Capacitance (NOTE 1)	CJ	140							pF
工作温度存储温度 Operating AND Storage Temperature Range	TSTG/ TJ	-55 to +150							℃

NOTE: 1.Measured at 1 MHz and Applied Reverse Voltage of 4.0 Volts D.C.

### RATING AND CHARACTERISTIC CURVES MR2501N/P THRU MR2507N/P

FIG. 1 –最大正向平均电流降额

FIG. 1 –MAXIMUM AVERAGE FORWARD CURRENT DERATING

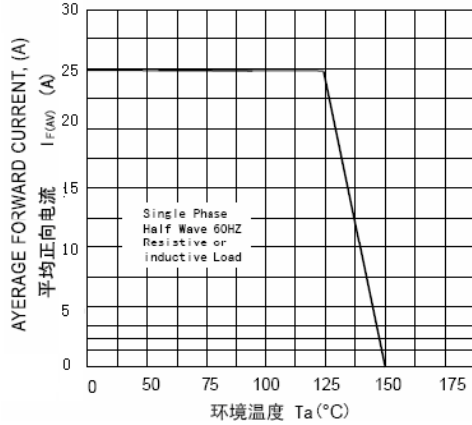

FIG. 2 –最大非重复正向浪涌电流

FIG. 2 –MAXIMUM NON-REPETITIVE FORWARD SURGE CURRENT

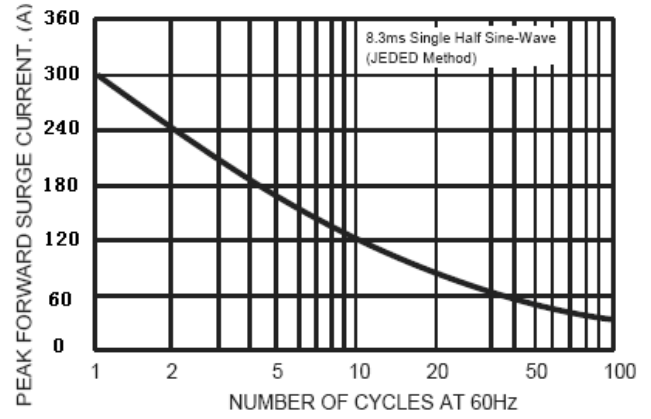

FIG. 3 –反向特性曲线(典型)

FIG. 3 –TYPICAL REVERSE CHARACTERISTICS

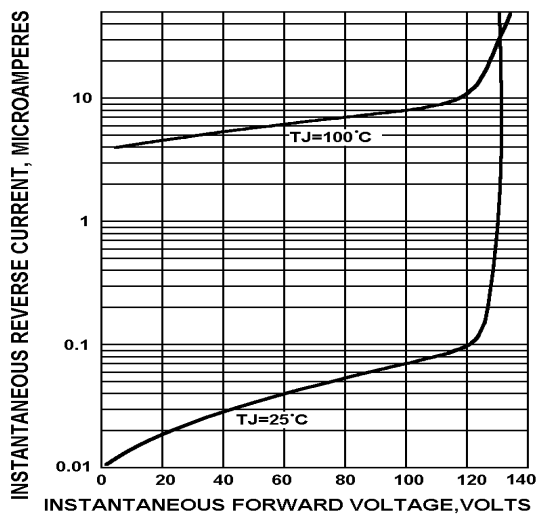

FIG. 4 –正向特性曲线(典型)

FIG. 4 –TYPICAL FORWARD CHARACTERISTICS

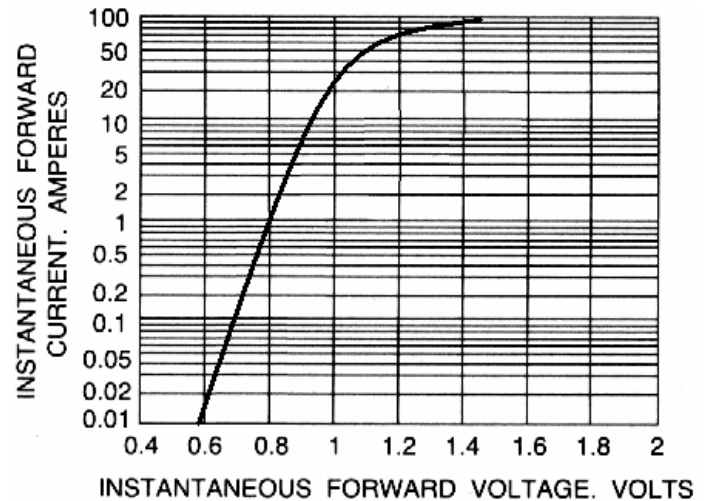

FIG.5 –结电容特性曲线

FIG.5 –TYPICAL JUNCTION CAPACITANCE

