

RBV4005-RBV410

Silicon Bridge Rectifiers

VOLTAGE RANGE: 50 --- 1000 V

CURRENT: 4.0 A



KBJ4

Features

- ◇ Ideal for printed circuit board
- ◇ Reliable low cost construction utilizing molded plastic technique
- ◇ Surge overload rating: 80 amperes peak

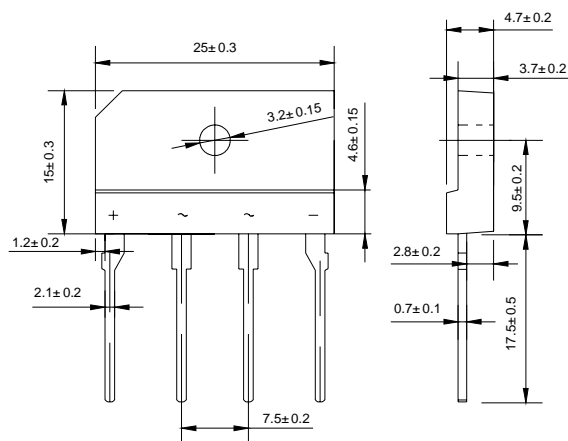

Dimensions in millimeters

MAXIMUM RATINGS AND ELECTRICAL CHARACTERISTICS

Ratings at 25°C ambient temperature unless otherwise specified.

Single phase, half wave, 60 Hz, resistive or inductive load. For capacitive load, derate by 20%.

		RBV 4005	RBV 401	RBV 402	RBV 404	RBV 406	RBV 408	RBV 410	UNITS
Maximum recurrent peak reverse voltage	V_{RRM}	50	100	200	400	600	800	1000	V
Maximum RMS voltage	V_{RMS}	35	70	140	280	420	560	700	V
Maximum DC blocking voltage	V_{DC}	50	100	200	400	600	800	1000	V
Maximum average forward Output current @ $T_c=50^\circ C$	$I_{F(AV)}$	4.0							A
Peak forward surge current 8.3ms single half-sine-wave superimposed on rated load	I_{FSM}	80							A
Maximum instantaneous forward voltage at 2.0 A	V_F	1.0							V
Maximum reverse current @ $T_A=25^\circ C$ at rated DC blocking voltage @ $T_A=100^\circ C$	I_R	10 100							μA
Operating junction temperature range	T_J	- 55 ---- + 150							$^\circ C$
Storage temperature range	T_{STG}	- 55 ---- + 150							$^\circ C$

Ratings AND Characteristic Curves

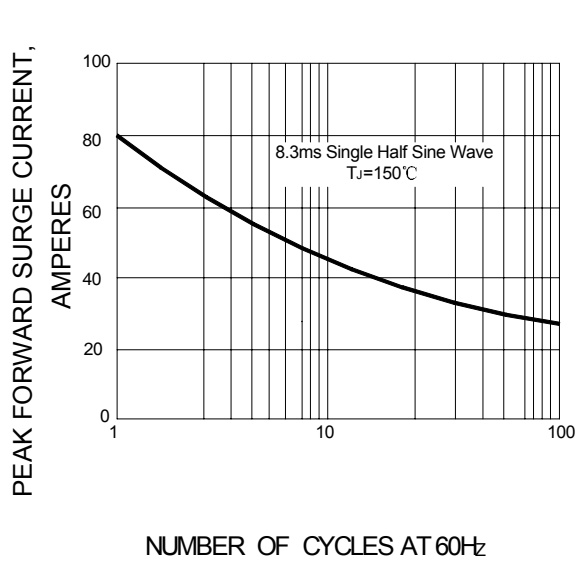
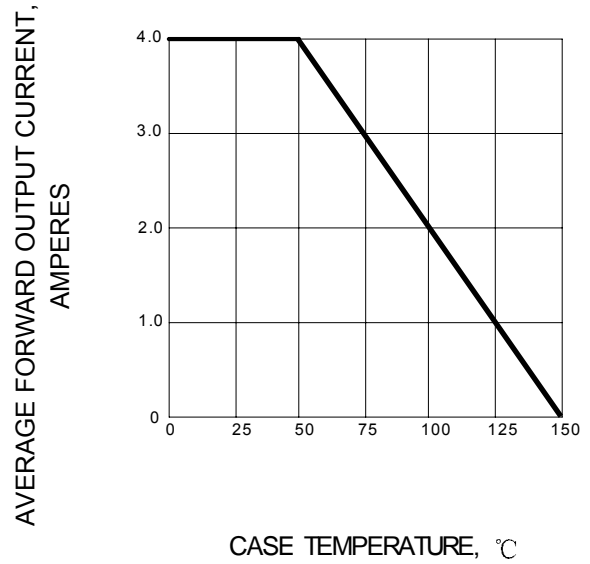
FIG.1 – PEAK FORWARD SURGE CURRENT

FIG.2 – FORWARD DERATING CURVE

FIG.3 – TYPICAL FORWARD CHARACTERISTIC
