

Ultra Fast Recovery Rectifiers

UFR8510 — UFR8520

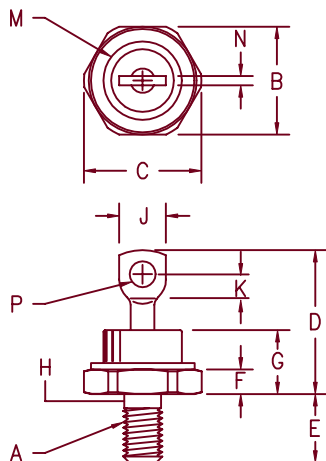

Notes:

1. Full threads within 2 1/2 threads
2. Standard Polarity: Stud is Cathode
Reverse Polarity: Stud is Anode

Dim.	Inches		Millimeter		Notes
	Minimum	Maximum	Minimum	Maximum	
A		1/4-28 UNF 3A	16.94		1
B	.667	.687	17.45		
C	---	.793	20.14		
D	---	1.00	25.40		
E	.422	.453	10.72	11.51	
F	.115	.200	2.92	5.08	
G	---	.450	---	11.43	
H	.220	.249	5.59	6.32	2
J	.250	.375	6.35	9.52	
K	.140	---	3.56	---	
M	---	.667	---	16.94	Dia
N	---	.080	---	2.03	
P	.140	.175	3.56	4.44	Dia

D0203AB (D05)

Microsemi Catalog Number	Working Peak Reverse Voltage	Peak Reverse Voltage
UFR8510*	100V	100V
UFR8515*	150V	150V
UFR8520*	200V	200V

*Add Suffix R For Reverse Polarity

- Ultra Fast Recovery Rectifier
- 175°C Junction Temperature
- 85 Amps current rating
- V_{RRM} 100 to 200 Volts
- t_{RR} 50 nsec maximum

Electrical Characteristics

Average forward current	$I_{F(AV)}$ 85 Amps	$T_C = 125^\circ\text{C}$, Square wave, $R_{\theta JC} = 0.6^\circ\text{C/W}$ 8.3 ms, half sine, $T_J = 175^\circ\text{C}$
Maximum surge current	I_{FSM} 1500 Amps	
Max peak forward voltage	V_{FM} .975 Volts	$I_{FM} = 85\text{A}$; $T_J = 25^\circ\text{C}^*$
Max reverse recovery time	t_{RR} 50 ns	1/2A, 1A, 1/4A, $T_J = 25^\circ\text{C}$
Max peak reverse current	I_{RM} 5 mA	V_{RRM} , $T_J = 125^\circ\text{C}$
Max peak reverse current	I_{RM} 50 μA	V_{RRM} , $T_J = 25^\circ\text{C}$
Typical Junction Capacitance	C_J 675 pF	$V_R = 10\text{V}$, $f = 1\text{Mhz}$, $T_J = 25^\circ\text{C}$

*Pulse test: Pulse width 300 μsec , Duty cycle 2%

Thermal and Mechanical Characteristics

Storage temp range	T_{STG}	-65°C to 175°C
Operating junction temp range	T_J	-65°C to 175°C
Max thermal resistance	$R_{\theta JC}$	0.6°C/W Junction to case
Typical thermal resistance (greased)	$R_{\theta CS}$	0.5°C/W Case to sink
Mounting torque		25-30 inch pounds
Weight		.52 ounces (14.7 grams) typical

UFR8510 — UFR8520

Figure 1
Typical Forward Characteristics

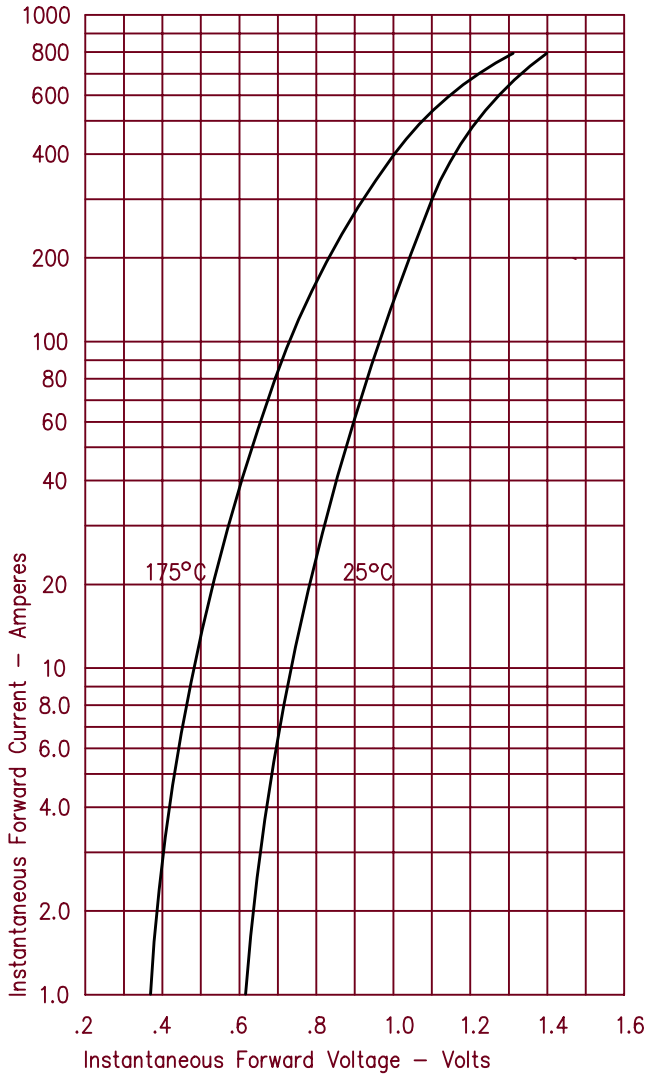

Figure 3
Typical Junction Capacitance

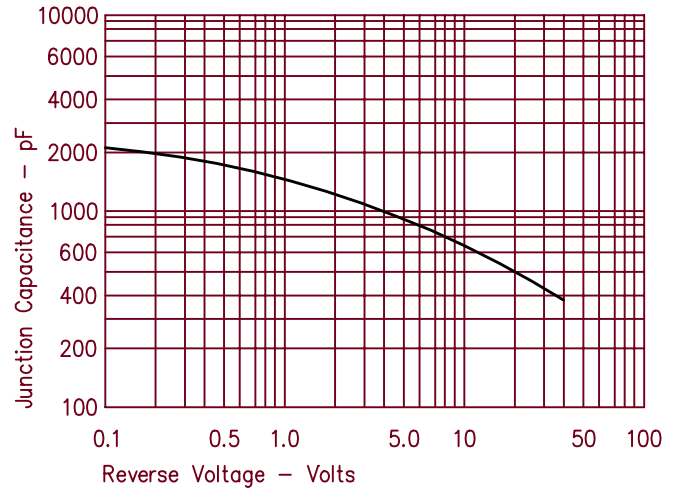

Figure 4
Forward Current Derating

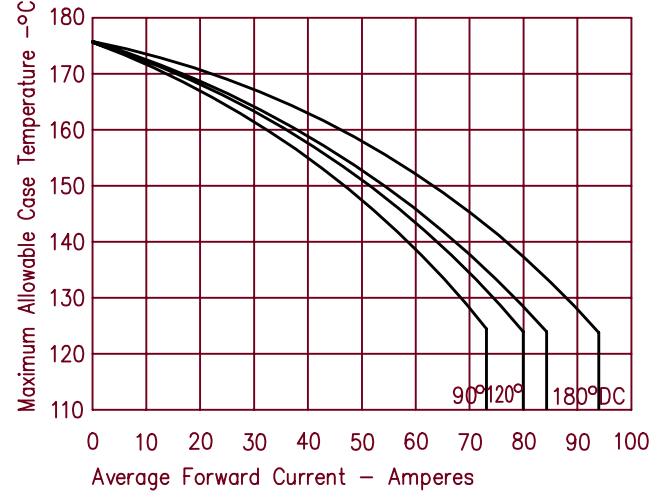

Figure 2
Typical Reverse Characteristics

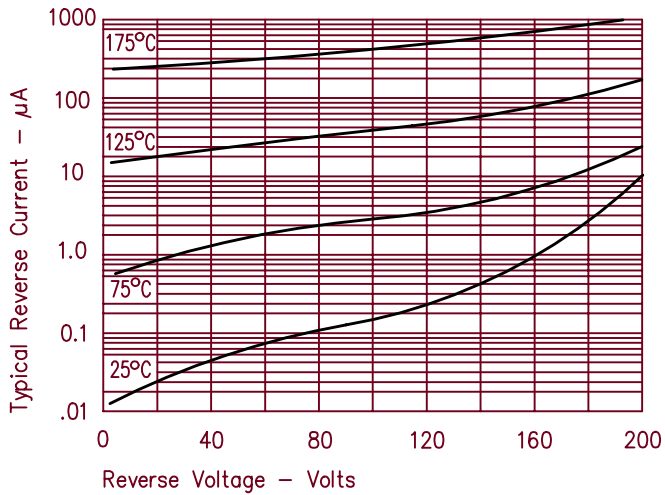

Figure 5
Maximum Forward Power Dissipation

