

60 Amp Schottky Rectifier

SBR6035 — SBR6045

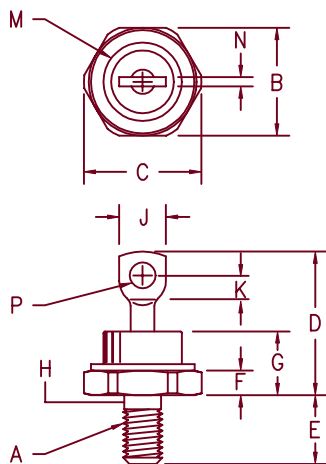

- Notes:
1. Full threads within 2 1/2 threads
 2. Standard Polarity: Stud is Cathode
Reverse Polarity: Stud is Anode

Dim.	Inches		Millimeter		Notes
	Minimum	Maximum	Minimum	Maximum	
A	----	----	----	----	1/4-28
B	.669	.688	17.00	17.47	
C	----	.794	----	20.16	
D	.750	1.00	19.05	25.40	
E	.422	.453	10.72	11.50	
F	.115	.200	2.93	5.08	
G	----	.450	----	11.43	
H	.220	.249	5.59	6.32	1
J	----	.375	----	9.52	
K	.156	----	3.97	----	
M	----	.510	----	12.95	Dia
N	----	.080	----	2.03	
P	.140	.175	3.56	4.44	Dia

DO-203AB (DO-5)

Microsemi Catalog Number	Industry Part Number	Working Peak Reverse Voltage	Peak Reverse Voltage
SBR6035*	50HQ035, 51HQ035 MBR6035	35V	35V
SBR6040*	50HQ040, 51HQ040 MBR6040	40V	40V
SBR6045*	50HQ045, 51HQ045 MBR6045	45V	45V

*Add Suffix R For Reverse Polarity

- Schottky Barrier Rectifier
- Low forward voltage
- Guard Ring Protected
- Reverse Energy Tested
- 150°C Junction Temperature
- VRRM -35 to 45 Volts

Electrical Characteristics

Average forward current per leg	I _{F(AV)} 60 Amps	T _C = 102°C, Square wave, R _{θJC} = 1.0°C/W
Maximum surge current per leg	I _{FSM} 1000 Amps	8.3ms, half sine, T _J = 125°C
Max repetitive peak reverse current	I _{R(OV)} 2 Amp	f = 1 KHz, 25°C, 1 μsec Square wave
Max peak forward voltage	V _{FM} .58 Volts	I _{FM} = 60A: 125°C *
Max peak forward voltage	V _{FM} .60 Volts	I _{FM} = 60A: 25°C *
Max peak reverse current	I _{RM} 600 mA	V _{RRM} , T _J = 125°C *
Max peak reverse current	I _{RM} 2.0 mA	V _{RRM} , T _J = 25°C
Typical junction capacitance	C _J 2700 pF	V _R = 5.0V, T _J = 25°C

*Pulse test: Pulse width 300 μsec, Duty cycle 2%

Thermal and Mechanical Characteristics

Storage temp range	T _{STG}	-65°C to 175°C
Operating junction temp range	T _J	-65°C to 150°C
Max thermal resistance	R _{θJC}	1.0°C/W Junction to Case
Typical thermal resistance (greased)	R _{θCS}	0.5°C/W Case to sink
Mounting torque		25-30 inch pounds
Weight		.54 ounces (15.3 grams) typical

SBR6035 — SBR6045

Figure 1
Typical Forward Characteristics

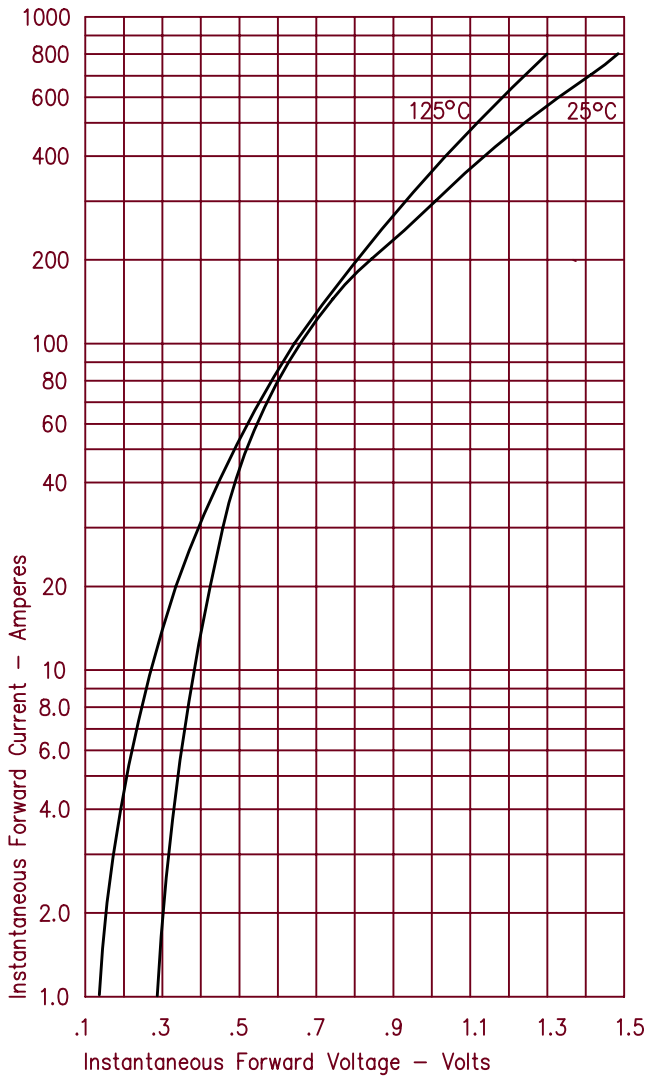

Figure 3
Typical Junction Capacitance

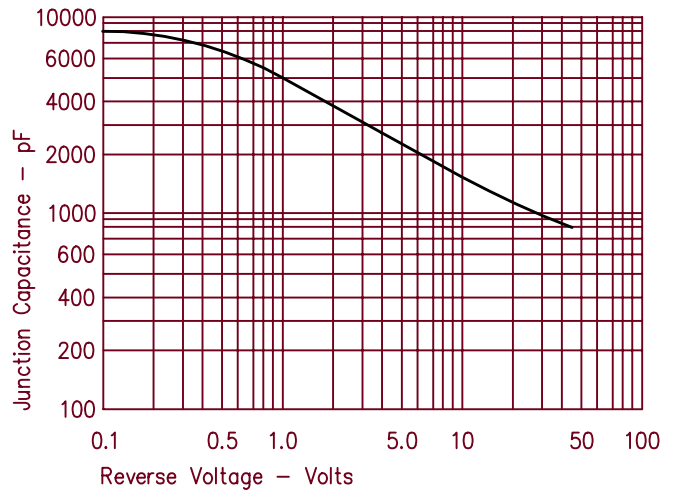

Figure 4
Forward Current Derating

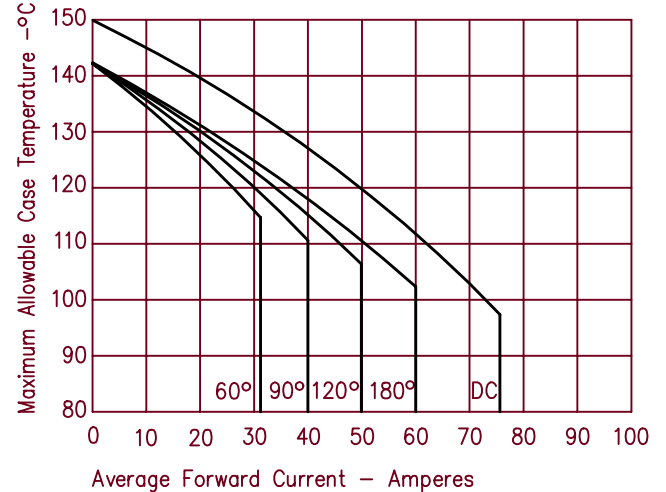

Figure 2
Typical Reverse Characteristics

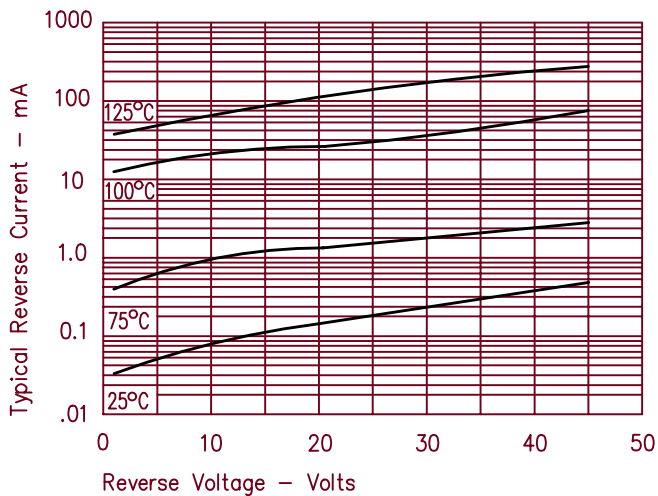

Figure 5
Maximum Forward Power Dissipation

