

High Voltage Standard Rectifier

Single Diode

$V_{RRM} = 2200 \text{ V}$
 $I_{FAV} = 30 \text{ A}$
 $V_F = 1.25 \text{ V}$

Part number

DNA 30 E 2200 FE

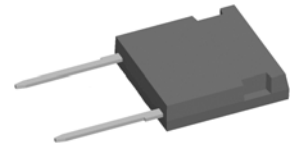
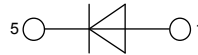

Backside: anode



Features / Advantages:

- Planar passivated chips
- Very low leakage current
- Very low forward voltage drop
- Improved thermal behaviour

Applications:

- Diode for main rectification
- For single and three phase bridge configurations

Package:

- Housing: i4-Pac
- DCB isolated backside
- Isolation Voltage 3000 V
- Epoxy meets UL 94V-0
- RoHS compliant

Ratings

Symbol	Definition	Conditions	Ratings			Unit	
			min.	typ.	max.		
V_{RRM}	max. repetitive reverse voltage				2200	V	
I_R	reverse current	$V_R = 2200 \text{ V}$			40	μA	
		$V_R = 2200 \text{ V}$			1.5	mA	
V_F	forward voltage	$I_F = 30 \text{ A}$			1.27	V	
		$I_F = 60 \text{ A}$			1.50	V	
		$I_F = 30 \text{ A}$	$T_{VJ} = 150^\circ\text{C}$			1.25	V
		$I_F = 60 \text{ A}$	$T_{VJ} = 150^\circ\text{C}$			1.59	V
I_{FAV}	average forward current	rectangular $d = 0.5$	$T_C = 105^\circ\text{C}$		30	A	
V_{F0}	threshold voltage	} for power loss calculation only	$T_{VJ} = 175^\circ\text{C}$		0.83	V	
r_F	slope resistance				12.2	m Ω	
R_{thJC}	thermal resistance junction to case				1.35	K/W	
T_{VJ}	virtual junction temperature		-55		175	$^\circ\text{C}$	
P_{tot}	total power dissipation		$T_C = 25^\circ\text{C}$		110	W	
I_{FSM}	max. forward surge current	$t = 10 \text{ ms}; (50 \text{ Hz}), \text{ sine}$	$T_{VJ} = 45^\circ\text{C}$		370	A	
		$t = 8,3 \text{ ms}; (60 \text{ Hz}), \text{ sine}$	$V_R = 0 \text{ V}$		400	A	
		$t = 10 \text{ ms}; (50 \text{ Hz}), \text{ sine}$	$T_{VJ} = 150^\circ\text{C}$		315	A	
		$t = 8,3 \text{ ms}; (60 \text{ Hz}), \text{ sine}$	$V_R = 0 \text{ V}$		340	A	
I^2t	value for fusing	$t = 10 \text{ ms}; (50 \text{ Hz}), \text{ sine}$	$T_{VJ} = 45^\circ\text{C}$		685	A ² s	
		$t = 8,3 \text{ ms}; (60 \text{ Hz}), \text{ sine}$	$V_R = 0 \text{ V}$		665	A ² s	
		$t = 10 \text{ ms}; (50 \text{ Hz}), \text{ sine}$	$T_{VJ} = 150^\circ\text{C}$		495	A ² s	
		$t = 8,3 \text{ ms}; (60 \text{ Hz}), \text{ sine}$	$V_R = 0 \text{ V}$		480	A ² s	
C_J	junction capacitance	$V_R = 700 \text{ V}; f = 1 \text{ MHz}$	$T_{VJ} = 25^\circ\text{C}$		7	pF	

Symbol	Definition	Conditions	Ratings			Unit
			min.	typ.	max.	
I_{RMS}	RMS current	per terminal			70	A
R_{thCH}	thermal resistance case to heatsink			0.20		K/W
T_{stg}	storage temperature		-55		150	°C
Weight				9		g
F_C	mounting force with clip		20		120	N
V_{ISOL}	isolation voltage	t = 1 second	3600			V
		t = 1 minute	3000			V
$d_{Spp/App}$	creepage striking distance on surface through air	terminal to terminal	13.8			mm
$d_{Spb/Apb}$	creepage striking distance on surface through air	terminal to backside	5.1			mm

Product Marking

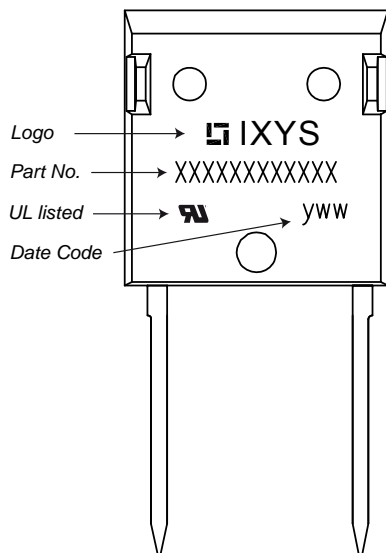

Part number

- D = Diode
- N = High Voltage Standard Rectifier
- A = (≥ 2200 V)
- 30 = Current Rating [A]
- E = Single Diode
- 2200 = Reverse Voltage [V]
- FE = i4-Pac (2HV)

Ordering	Ordering Number	Marking on Product	Delivery Mode	Quantity	Code No.
Standard	DNA 30 E 2200 FE	DNA30E2200FE	Tube	25	508861

Similar Part	Package	Voltage class
DNA30E2200PA	TO-220AC (2)	2200
DNA30E2200PC	TO-263AB (D2Pak)	2200
DNA30EM2200PC	TO-263AB (D2Pak)	2200

Outlines i4-Pac

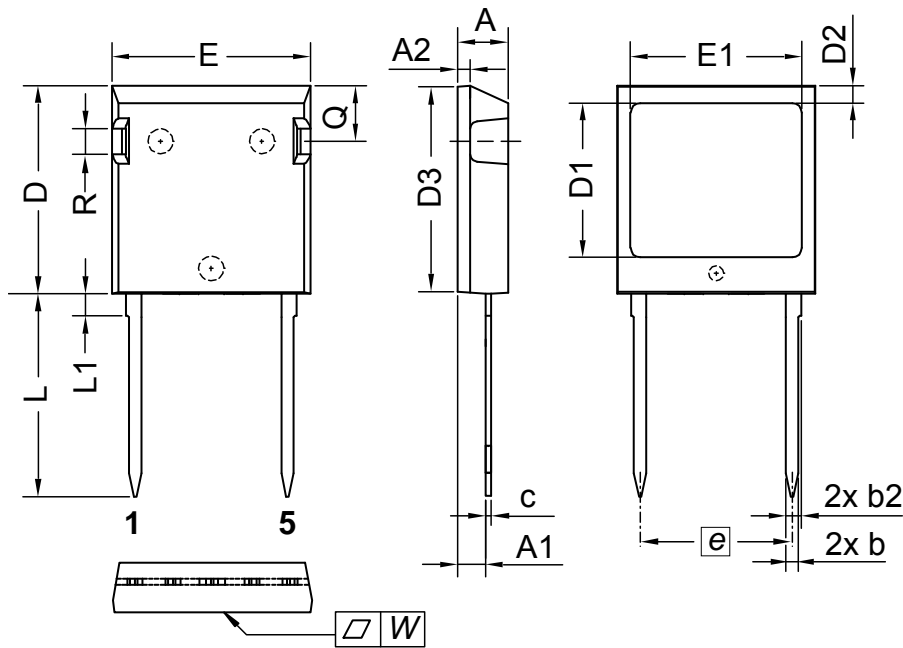

Dim.	Millimeter		Inches	
	min	max	min	max
A	4.83	5.21	0.190	0.205
A1	2.59	3.00	0.102	0.118
A2	1.17	2.16	0.046	0.085
b	1.14	1.40	0.045	0.055
b2	1.47	1.73	0.058	0.068
c	0.51	0.74	0.020	0.029
D	20.80	21.34	0.819	0.840
D1	14.99	15.75	0.590	0.620
D2	1.65	2.03	0.065	0.080
D3	20.30	20.70	0.799	0.815
E	19.56	20.29	0.770	0.799
E1	16.76	17.53	0.660	0.690
e	15.24	BSC	0.600	BSC
L	19.81	21.34	0.780	0.840
L1	2.11	2.59	0.083	0.102
Q	5.33	6.20	0.210	0.244
R	2.54	4.57	0.100	0.180
W	-	0.10	-	0.004

Die konvexe Form des Substrates ist typ. < 0.05 mm über der Kunststoffoberfläche der Bauteilunterseite
 The convexbow of substrate is typ. < 0.05 mm over plastic surface level of device bottom side

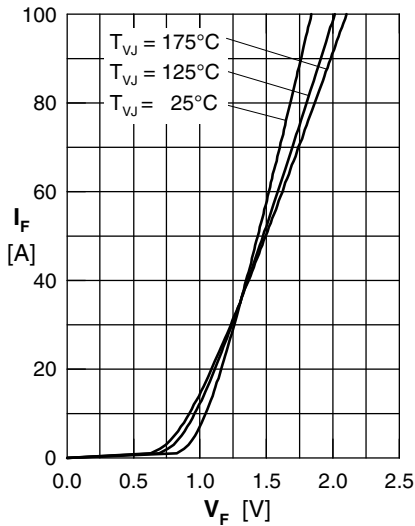

Fig. 1 Forward current versus voltage drop per diode

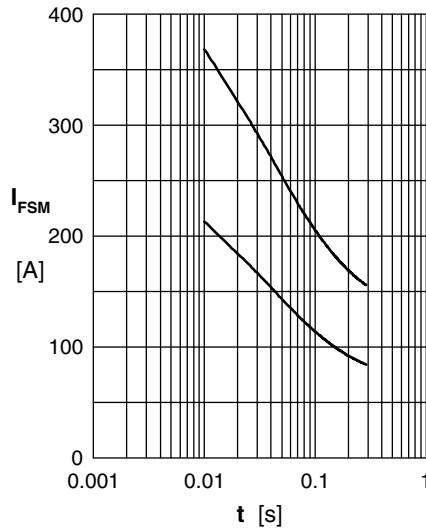

Fig. 2 Surge overload current

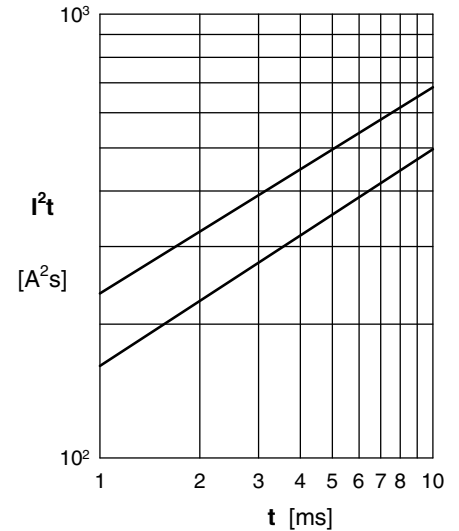

Fig. 3 I^2t versus time per diode

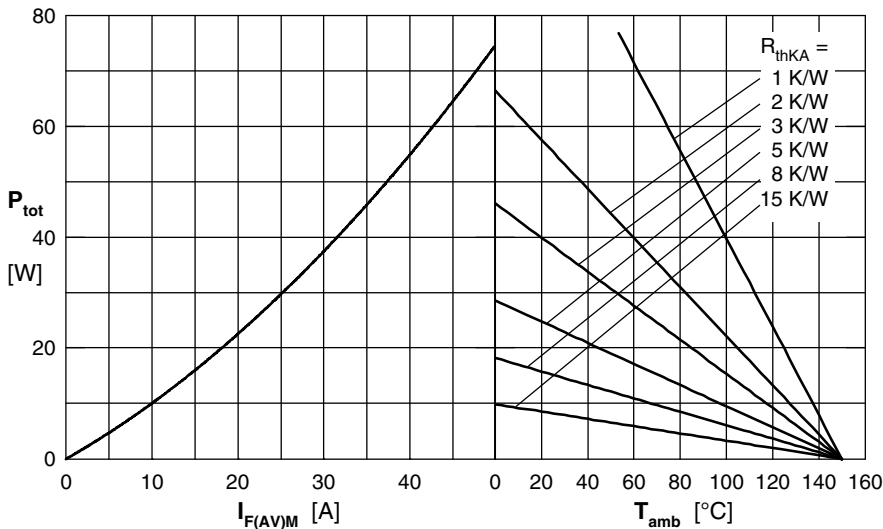

Fig. 4 Power dissipation vs. direct output current & ambient temperature, sine 180°

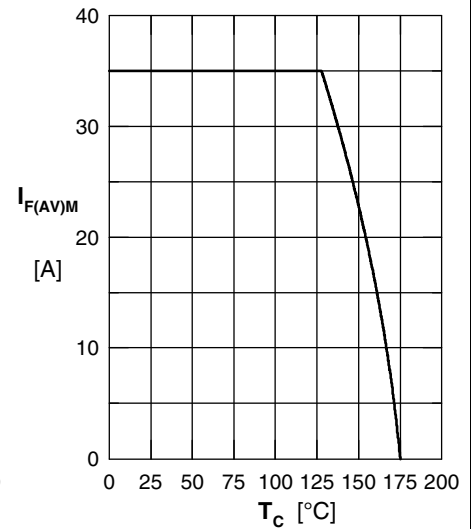

Fig. 5 Max. forward current versus case temperature, sine 180°

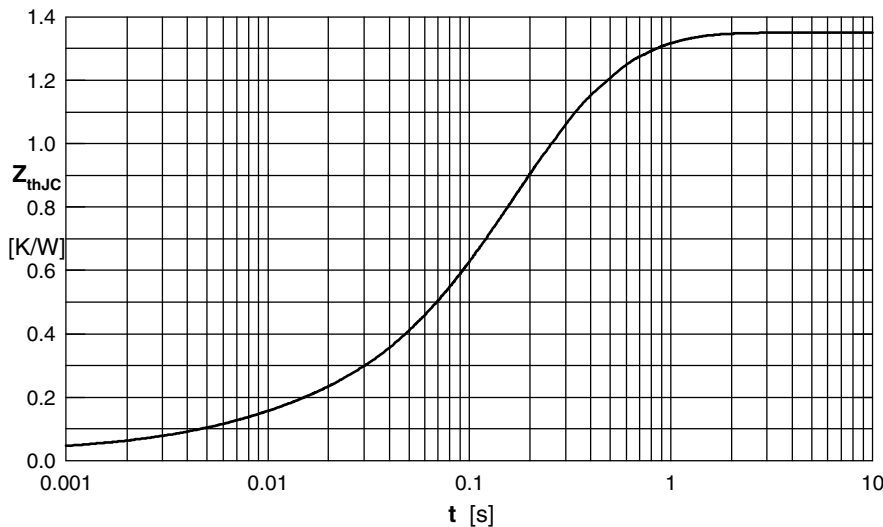

Fig. 6 Transient thermal impedance junction to case

Constants for Z_{thJC} calculation:

i	R_{thi} (K/W)	t_i (s)
1	0.03	0.0003
2	0.072	0.0065
3	0.122	0.083
4	0.736	0.152
5	0.39	0.4