

preliminary

# Schottky Diode Gen<sup>2</sup>

High Performance Schottky Diode  
Low Loss and Soft Recovery  
Single Diode

Part number

**DSA 15 IM 200 UC**

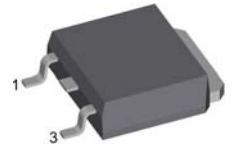
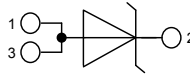
 Marking on Product: *SFMAUI*

Backside: cathode

**Features / Advantages:**

- Very low  $V_f$
- Extremely low switching losses
- low  $I_{RM}$  values
- Improved thermal behaviour
- High reliability circuit operation
- Low voltage peaks for reduced protection circuits
- Low noise switching

**Applications:**

- Rectifiers in switch mode power supplies (SMPS)
- Free wheeling diode in low voltage converters

**Package:**

- Housing: TO-252 (DPak)
- Industry standard outline
- Epoxy meets UL 94V-0
- RoHS compliant

**Ratings**

Symbol	Definition	Conditions	Ratings			Unit
			min.	typ.	max.	
$V_{RRM}$	max. repetitive reverse voltage				200	V
$I_R$	reverse current	$V_R = 200\text{ V}$			0.25	mA
		$V_R = 200\text{ V}$			2.5	mA
$V_F$	forward voltage	$I_F = 15\text{ A}$			0.94	V
		$I_F = 30\text{ A}$			1.10	V
		$I_F = 15\text{ A}$			0.78	V
		$I_F = 30\text{ A}$			0.95	V
$I_{FAV}$	average forward current	rectangular $d = 0.5$			15	A
$V_{F0}$	threshold voltage				0.53	V
$r_F$	slope resistance					
$R_{thJC}$	thermal resistance junction to case				2.00	K/W
$T_{VJ}$	virtual junction temperature		-55		175	°C
$P_{tot}$	total power dissipation				75	W
$I_{FSM}$	max. forward surge current	$t = 10\text{ ms}$ (50 Hz), sine			80	A
$C_J$	junction capacitance	$V_R = 24\text{ V}$ ; $f = 1\text{ MHz}$		67		pF

Symbol	Definition	Conditions	Ratings			Unit
			min.	typ.	max.	
$I_{RMS}$	RMS current	per terminal <sup>1)</sup>			20	A
$R_{thCH}$	thermal resistance case to heatsink			0.50		K/W
$T_{stg}$	storage temperature		-55		150	°C
<b>Weight</b>				0.3		g
$F_C$	mounting force with clip		20		60	N

<sup>1)</sup>  $I_{RMS}$  is typically limited by the pin-to-chip resistance (1); or by the current capability of the chip (2).  
 In case of (1) and a product with multiple pins for one chip-potential, the current capability can be increased by connecting the pins as one contact.

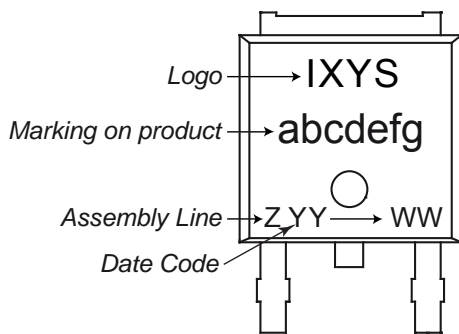
**Product Marking**

- a) S = Semiconductor
- b) F = Current Rating
- c) M = Voltage Class
- d) A = Technology
- e) U = Package
- f) I = Configuration

**Part number**

- D = Diode
- S = Schottky Diode
- A = low VF
- 15 = Current Rating [A]
- IM = Single Diode
- 200 = Reverse Voltage [V]
- UC = TO-252AA (DPak)

Ordering	Ordering Number	Marking on Product	Delivery Mode	Quantity	Code No.
Standard	DSA 15 IM 200 UC	SFMAUI	Tape & Reel	2500	510408

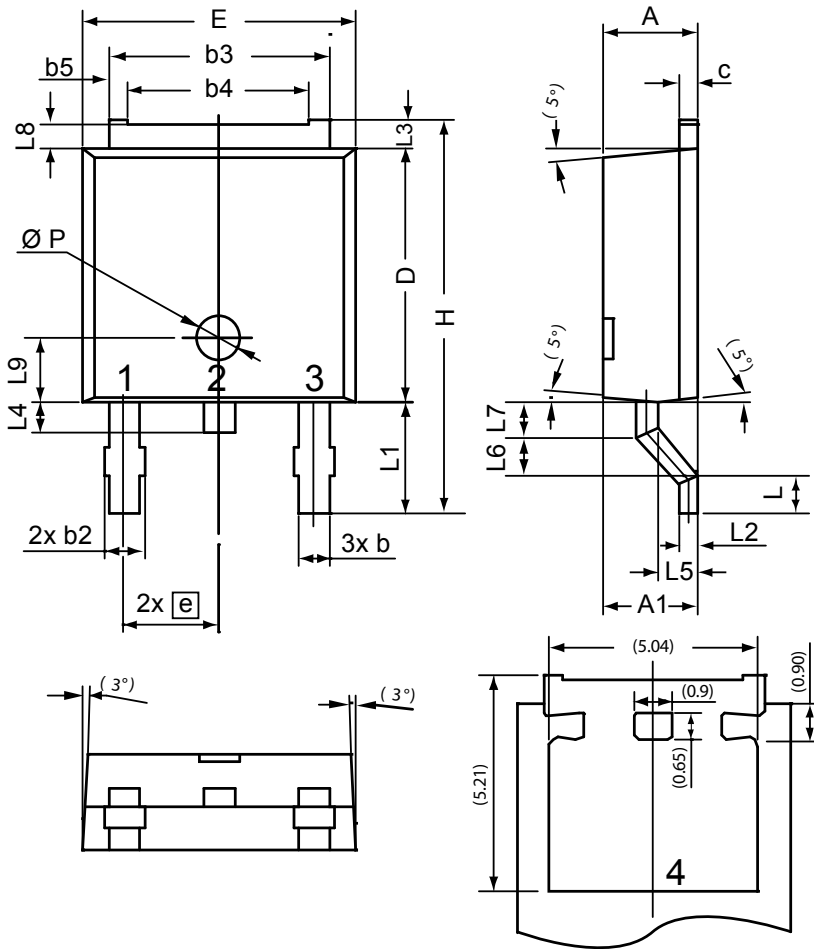
**Outlines TO-252 (DPak)**

Dim.	Millimeters		Inches	
	min	max	min	max
A	2.20	2.40	0.087	0.094
A1	2.10	2.50	0.083	0.098
b	0.66	0.86	0.026	0.034
b2	-	0.96	-	0.038
b3	5.04	5.64	0.198	0.222
b4	4.34 BSC		0.171 BSC	
b5	0.50 BSC		0.020 BSC	
c	0.40	0.60	0.016	0.024
D	5.90	6.30	0.232	0.248
E	6.40	6.80	0.252	0.268
e	2.10	2.50	0.083	0.098
H	9.20	9.80	0.362	0.386
L	0.55	1.02	0.022	0.040
L1	2.50	2.90	0.098	0.114
L2	0.40	0.60	0.016	0.024
L3	0.50	0.90	0.020	0.035
L4	0.60	1.00	0.024	0.039
L5	0.82	1.22	0.032	0.048
L6	0.79	0.99	0.031	0.039
L7	0.81	1.01	0.032	0.040
L8	0.40	0.80	0.016	0.031
L9	1.50 BSC		0.059 BSC	
Ø P	1.00 BSC		0.039 BSC	

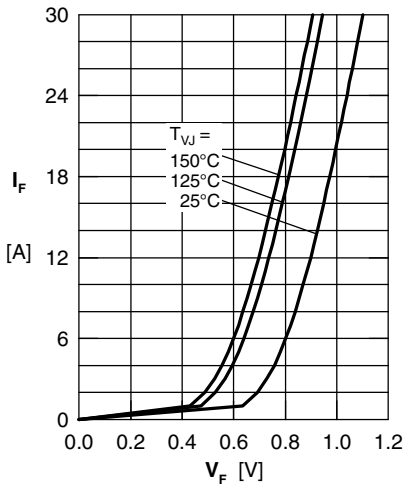

Fig. 1 Maximum forward voltage drop characteristics

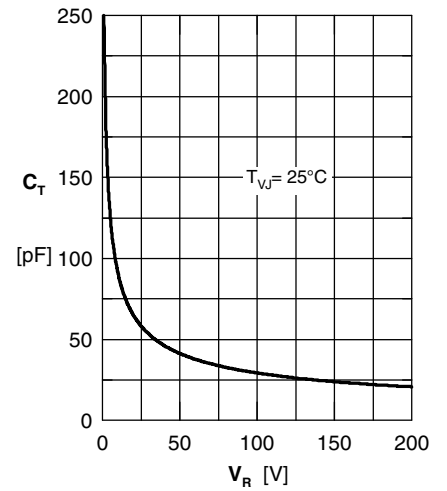

Fig. 3 Typ. junction capacitance  $C_T$  vs. reverse voltage  $V_R$

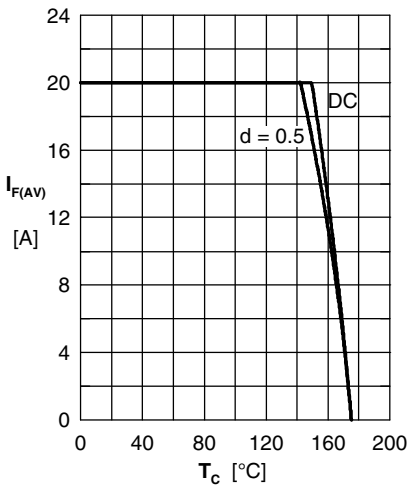

Fig. 4 Avg: forward current  $I_{F(AV)}$  vs. case temperature  $T_C$

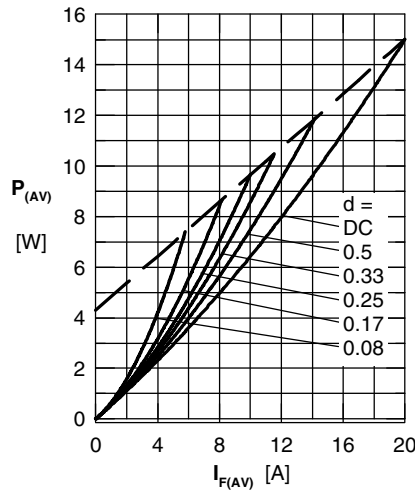

Fig. 5 Forward power loss characteristics

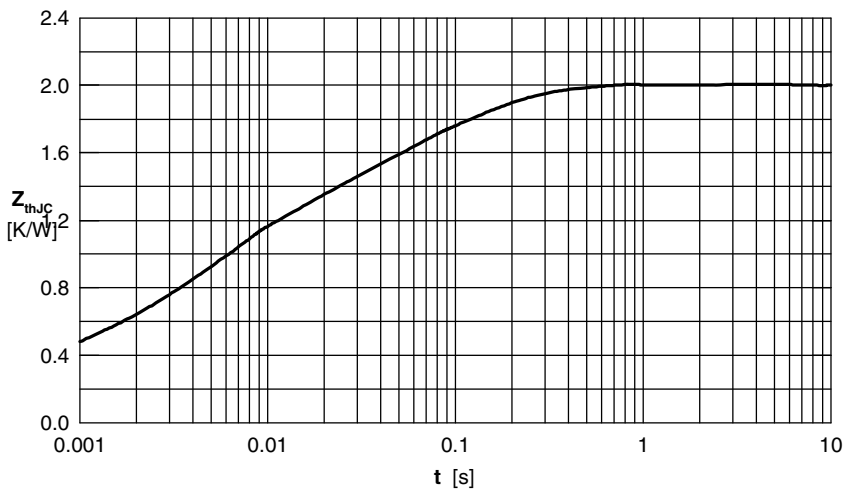

Fig. 6 Transient thermal impedance junction to case