

# Schottky Power Surface Mount FST80150SM1 – SM6 Series

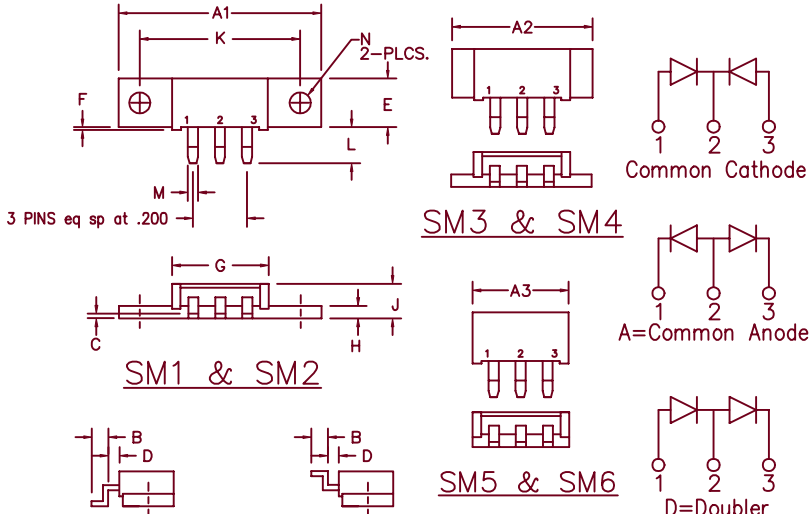

TYP. PIN CONFIGURATION FOR SM1, SM3, & SM5  
TYP. PIN CONFIGURATION FOR SM2, SM4, & SM6

Note: Baseplate Common with Pin 2

Dim.	Inches		Millimeter		Notes
	Minimum	Maximum	Minimum	Maximum	
A1	1.490	1.510	37.85	38.35	
A2	1.020	1.040	26.12	26.42	
A3	.695	.715	17.65	18.16	
B	.110	.120	2.79	3.04	
C	.027	.037	0.69	0.94	
D	.100	.110	2.54	2.79	
E	.350	.370	8.89	9.40	
F	.015	.025	0.38	0.64	
G	.695	.715	17.65	18.16	
H	.088	.098	2.24	2.49	
J	.240	.260	6.10	6.60	
K	1.180	1.195	29.97	30.35	
L	.230	.250	5.84	6.35	
M	.065	.085	1.65	2.16	
N	.151	.161	3.84	4.09	Dia.

Microsemi Catalog Catalog Number	Industry Part Number	Working Peak Reverse Voltage	Repetitive Peak Reverse Voltage
FST80150SM <sup>①</sup> <sub>-</sub> <sup>②</sup> <sub>-</sub>	89CNQ150ASL 89CNQ150ASM	150V	150V

Note: ① Specify (1-6) to identify package desired  
② Specify C-Common Cathode, A-Common Anode, D-Doubler

- Schottky Barrier Rectifier
- Guard Ring Protection
- 2 X 40 Amperes Avg.
- 175°C Junction Temperature
- Reverse Energy Tested
- $V_{RRM}$  – 150 Volts

## Electrical Characteristics

Average forward current per pkg	$I_{F(AV)}$ 80 Amps	$T_C = 144^\circ\text{C}$ , Square wave, $R_{\theta JC} = 0.5^\circ\text{C/W}$
Average forward current per leg	$I_{F(AV)}$ 40 Amps	$T_C = 144^\circ\text{C}$ , Square wave, $R_{\theta JC} = 1.0^\circ\text{C/W}$
Maximum surge current per leg	$I_{FSM}$ 1000 Amps	8.3 ms, half sine, $T_J = 175^\circ\text{C}$
Max repetitive peak reverse current per leg	$I_{R(OV)}$ 2 Amps	$f = 1 \text{ KHZ}$ , $25^\circ\text{C}$ , 1 usec square wave
Max peak forward voltage per leg	$V_{FM}$ 0.86 volts	$I_{FM} = 40\text{A}$ ; $T_J = 25^\circ\text{C}^*$
Max peak reverse current per leg	$I_{RM}$ 10 mA	$V_{RRM}$ , $T_C = 125^\circ\text{C}^*$
Max peak reverse current per leg	$I_{RM}$ 2.0 mA	$V_{RRM}$ , $T_J = 25^\circ\text{C}$
Typical junction capacitance per leg	$C_J$ 970 pF	$V_R = 5.0\text{V}$ , $T_C = 25^\circ\text{C}$

\*Pulse test: Pulse width 300 usec, Duty cycle 2%

## Thermal and Mechanical Characteristics

Storage temp range	$T_{STG}$	$-55^\circ\text{C}$ to $175^\circ\text{C}$
Operating junction temp range	$T_J$	$-55^\circ\text{C}$ to $175^\circ\text{C}$
Max thermal resistance per leg	$R_{\theta JC}$	$1.0^\circ\text{C/W}$ Junction to case
Max thermal resistance per pkg.	$R_{\theta JC}$	$0.5^\circ\text{C/W}$ Junction to case
Typical thermal resistance (greased)	$R_{\theta CS}$	$0.3^\circ\text{C/W}$ Case to sink
Mounting Base Torque		10 inch pounds maximum (SM1, 2)
Weight		SM1-2 0.3 ounce (8.4 grams) typical SM3-4 0.24 ounce (6.7 grams) typical SM5-6 0.18 ounce (5.2 grams) typical

# FST80150SM1 – SM6

Figure 1  
Typical Forward Characteristics

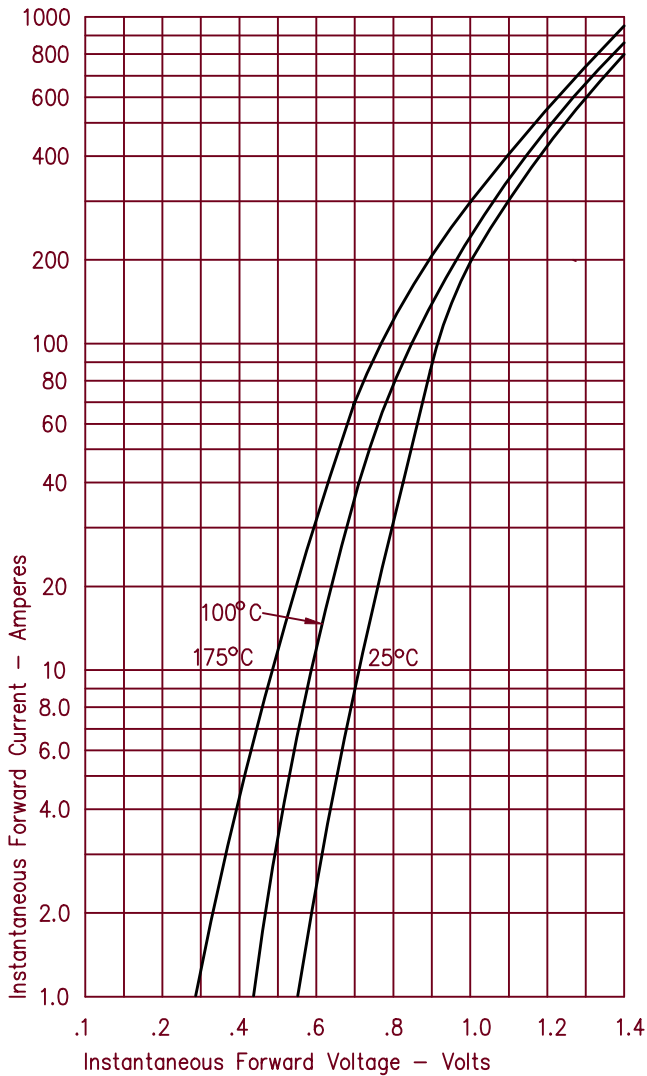

Figure 3  
Typical Junction Capacitance

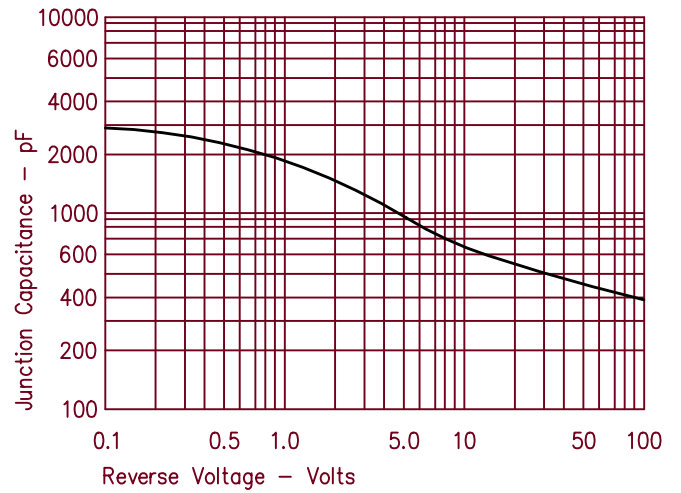

Figure 4  
Forward Current Derating – Per Leg

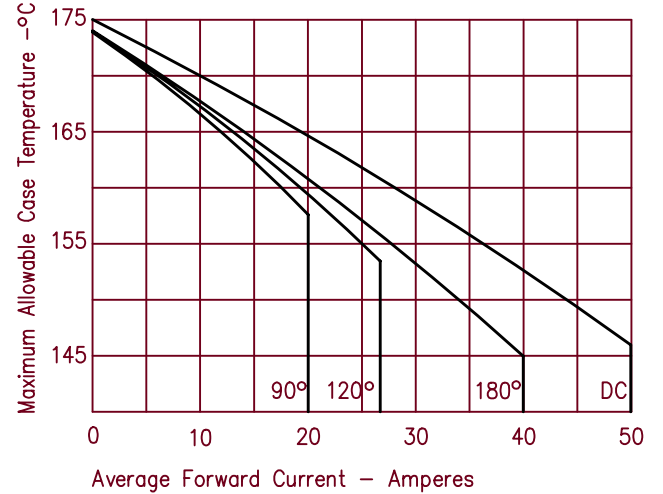

Figure 2  
Typical Reverse Characteristics

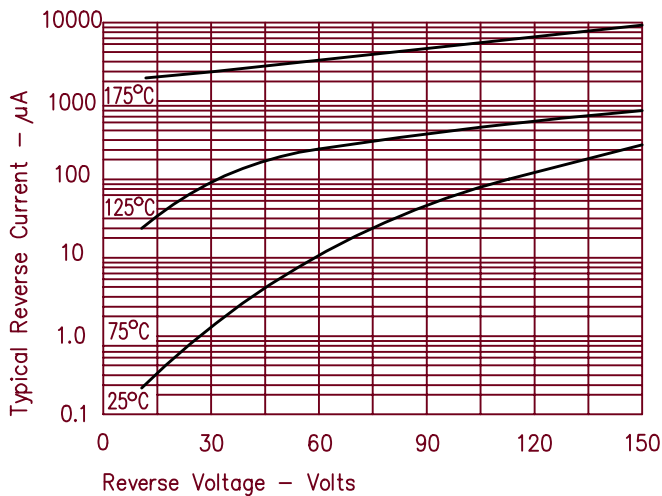

Figure 5  
Maximum Forward Power Dissipation

