

# Schottky PowerMod

## CPT20130 — CPT20145

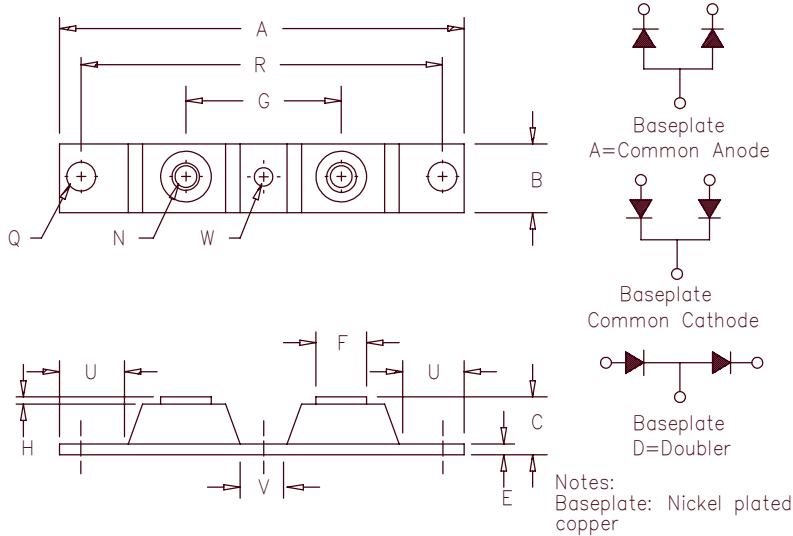

Dim.	Inches		Millimeters		Notes
	Min.	Max.	Min.	Max.	
A	---	3.630	---	92.20	
B	0.700	0.800	17.78	20.32	
C	---	0.630	---	16.00	
E	0.120	0.130	3.05	3.30	
F	0.490	0.510	12.45	12.95	
G	1.375 BSC		34.92 BSC		
H	0.010	---	0.25	---	
N	---	---	---	---	1/4-28
Q	0.275	0.290	6.99	7.37	Dia.
R	3.150 BSC		80.01 BSC		
U	0.600	---	15.24	---	
V	0.312	0.340	7.92	8.64	
W	0.180	0.195	4.57	4.95	Dia.

Microsemi Catalog Number	Industry Part Number	Working Peak Reverse Voltage	Repetitive Peak Reverse Voltage
CPT20130*	MBR20030CT	30V	30V
CPT20135*	200CNQ035 224CNQ035 MBR20035CT	35V	35V
CPT20140*	200CNQ040 224CNQ040 MBR20040CT	40V	40V
CPT20145*	200CNQ045 224CNQ045 MBR20045CT	45V	45V

\*Add Suffix A for Common Anode, D for Doubler

- Schottky Barrier Rectifier
- Guard Ring Protection
- 200 Amperes/30 to 45 Volts
- 150° C Junction Temperature
- Reverse Energy Tested
- ROHS Compliant

### Electrical Characteristics

Average forward current per pkg	$I_{F(AV)}$ 200 Amps	$T_C = 99^\circ\text{C}$ , Square wave, $R_{\theta JC} = .20^\circ\text{C/W}$
Average forward current per leg	$I_{F(AV)}$ 100 Amps	$T_C = 99^\circ\text{C}$ , Square wave, $R_{\theta JC} = .40^\circ\text{C/W}$
Maximum surge current per leg	$I_{FSM}$ 2000 Amps	8.3ms, half sine, $T_J = 125^\circ\text{C}$
Maximum repetitive reverse current per leg	$I_{R(OV)}$ 2 Amps	$f = 1 \text{ KHZ}$ , $25^\circ\text{C}$
Max peak forward voltage per leg	$V_{FM}$ 0.68 Volts	$I_{FM} = 200\text{A}$ ; $T_J = 25^\circ\text{C}^*$
Max peak forward voltage per leg	$V_{FM}$ 0.64 Volts	$I_{FM} = 200\text{A}$ ; $T_J = 125^\circ\text{C}^*$
Max peak reverse current per leg	$I_{RM}$ 1100mA	$V_{RRM}$ , $T_J = 125^\circ\text{C}^*$
Max peak reverse current per leg	$I_{RM}$ 4.0mA	$V_{RRM}$ , $T_J = 25^\circ\text{C}$
Typical junction capacitance	$C_J$ 5500pF	$V_R = 5.0\text{V}$ , $T_C = 25^\circ\text{C}$

\*Pulse test: Pulse width 300 $\mu\text{sec}$ , Duty cycle 2%

### Thermal and Mechanical Characteristics

Storage temp range	$T_{STG}$	-55°C to 150°C
Operating junction temp range	$T_J$	-55°C to 150°C
Max thermal resistance per leg	$R_{\theta JC}$	0.40°C/W Junction to case
Typical thermal resistance (greased)	$R_{\theta CS}$	0.08°C/W Case to sink
Terminal Torque		35-50 inch pounds
Mounting Base Torque (outside holes)		30-40 inch pounds
Mounting Base Torque (center hole)		8-10 inch pounds
center hole must be torqued first		
Weight		2.8 ounces (75 grams) typical

# CPT20130 – CPT20145

Figure 1  
Maximum Forward Characteristics – Per Leg

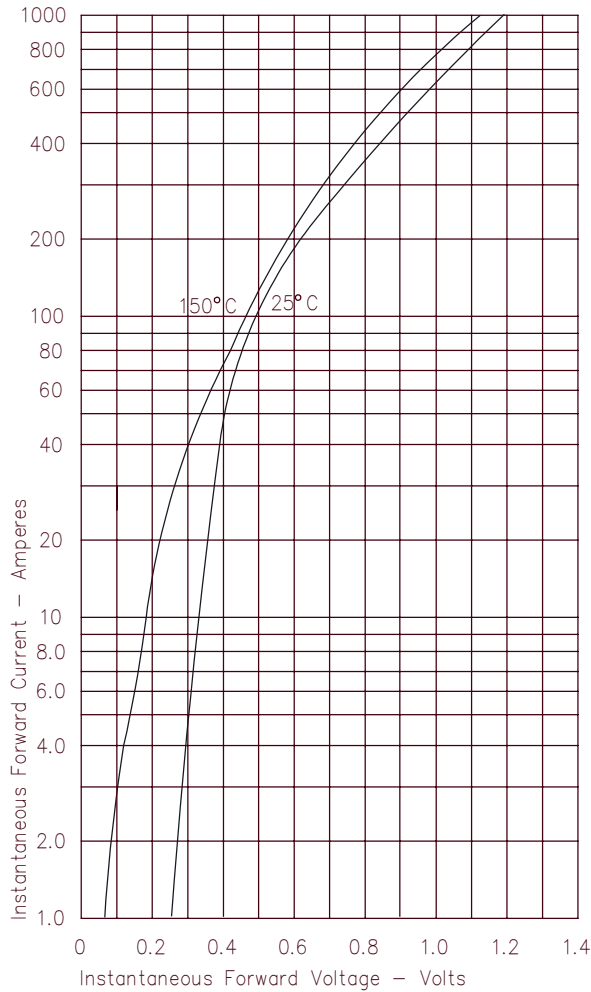

Figure 3  
Typical Junction Capacitance – Per Leg

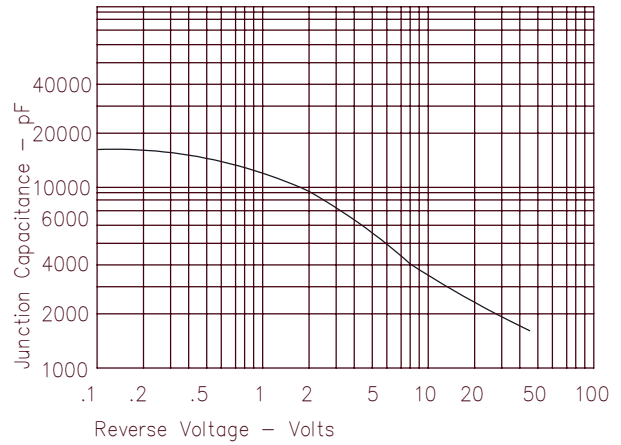

Figure 4  
Forward Current Derating – Per Leg

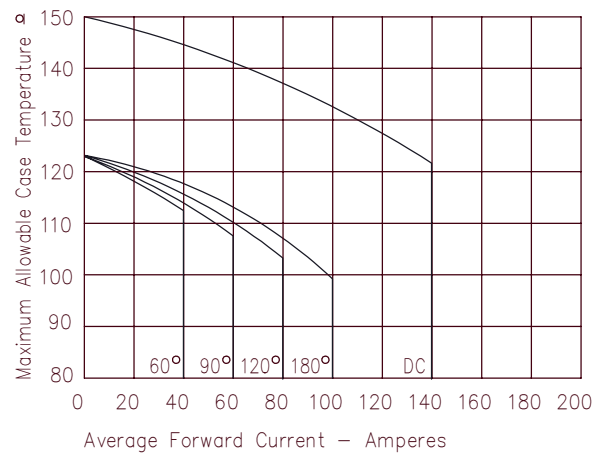

Figure 2  
Typical Reverse Characteristics – Per Leg

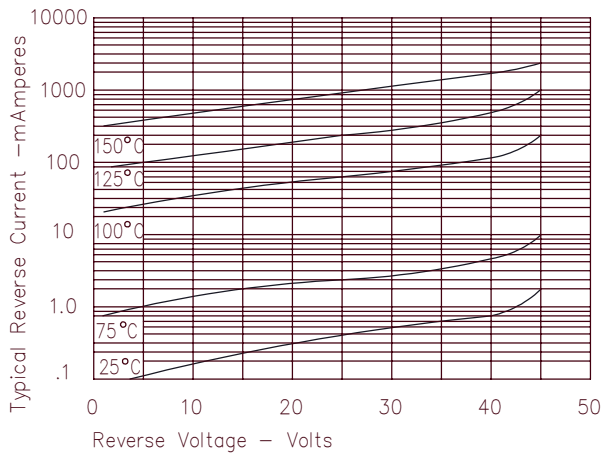

Figure 5  
Maximum Forward Power Dissipation – Per Leg

