

Schottky PowerMod

CPT60035 — CPT60045

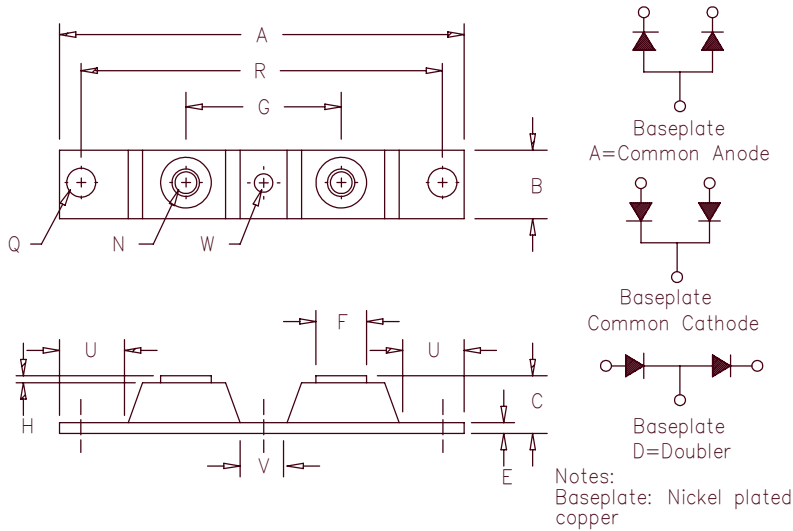

Dim.	Inches		Millimeters		Notes
	Min.	Max.	Min.	Max.	
A	---	3.630	---	92.20	
B	0.700	0.800	17.78	20.32	
C	---	0.680	---	17.28	
E	0.120	0.130	3.05	3.30	
F	0.490	0.510	12.45	12.95	
G	1.375 BSC		34.92 BSC		
H	0.010	---	0.25	---	
N	---	---	---	---	1/4-20 Dia.
Q	0.275	0.290	6.99	7.37	
R	3.150 BSC		80.01 BSC		
U	0.600	---	15.24	---	
V	0.312	0.340	7.92	8.64	
W	0.180	0.195	4.57	4.95	Dia.

Microsemi Catalog Number	Industry Part Number	Working Peak Reverse Voltage	Repetitive Peak Reverse Voltage
CPT60035*	MBRP60035CTL	35V	35V
CPT60040*		40V	40V
CPT60045*		45V	45V

*Add Suffix A for Common Anode, D for Doubler

- Schottky Barrier Rectifier
- Guard Ring Protection
- 600 Amperes/35 to 45 Volts
- 175°C Junction Temperature
- Reverse Energy Tested
- ROHS Compliant

Electrical Characteristics

Average forward current per pkg	$I_{F(AV)}$ 600 Amps	$T_C = 139^\circ\text{C}$, Square wave, $R_{\theta JC} = 0.10^\circ\text{C/W}$
Average forward current per leg	$I_{F(AV)}$ 300 Amps	$T_C = 139^\circ\text{C}$, Square wave, $R_{\theta JC} = 0.20^\circ\text{C/W}$
Maximum surge current per leg	I_{FSM} 6000 Amps	8.3ms, half sine, $T_J = 175^\circ\text{C}$
Maximum repetitive reverse current per leg	$I_{R(OV)}$ 2 Amps	$f = 1 \text{ KHZ}$, 25°C , $1\mu\text{sec}$ square wave
Max peak forward voltage per leg	V_{FM} 0.65 Volts	$I_{FM} = 300\text{A}$; $T_J = 25^\circ\text{C}$
Max peak forward voltage per leg	V_{FM} 0.52 Volts	$I_{FM} = 300\text{A}$; $T_J = 175^\circ\text{C}$
Max peak reverse current per leg	I_{RM} 75 mA	V_{RRM} , $T_J = 125^\circ\text{C}^*$
Max peak reverse current per leg	I_{RM} 8.0 mA	V_{RRM} , $T_J = 25^\circ\text{C}$
Typical junction capacitance per leg	C_J 14000 pF	$V_R = 5.0\text{V}$, $T_C = 25^\circ\text{C}$

*Pulse test: Pulse width 300 μsec , Duty cycle 2%

Thermal and Mechanical Characteristics

Storage temp range	T_{STG}	-55°C to 175°C
Operating junction temp range	T_J	-55°C to 175°C
Max thermal resistance per leg	$R_{\theta JC}$	0.20°C/W Junction to case
Max thermal resistance per pkg	$R_{\theta JC}$	0.10°C/W Junction to case
Typical thermal resistance (greased)	$R_{\theta CS}$	0.08°C/W Case to sink
Terminal Torque		35-50 inch pounds
Mounting Base Torque (outside holes)		30-40 inch pounds
Mounting Base Torque (center hole) center hole must be torqued first		8-10 inch pounds
Weight		2.8 ounces (78 grams) typical

CPT60035 — CPT60045

Figure 1
Typical Forward Characteristics — Per Leg

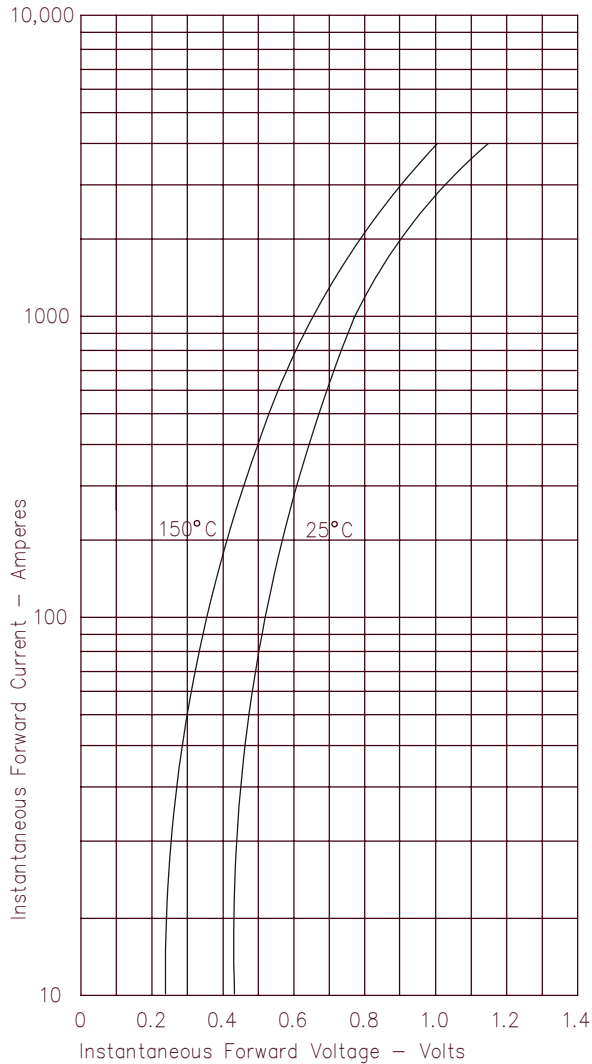

Figure 3
Typical Junction Capacitance — Per Leg

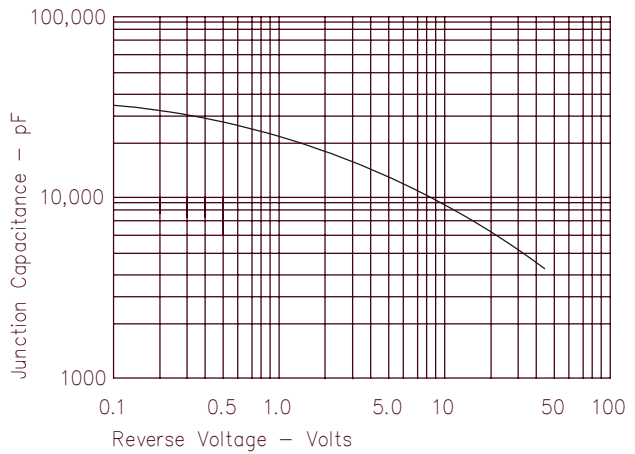

Figure 4
Forward Current Derating — Per Leg

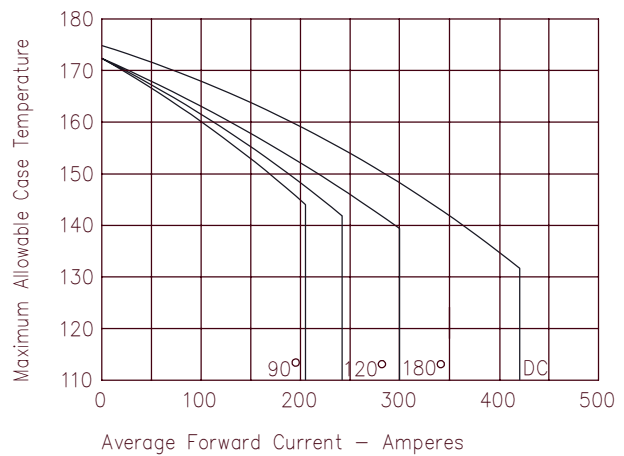

Figure 2
Typical Reverse Characteristics — Per Leg

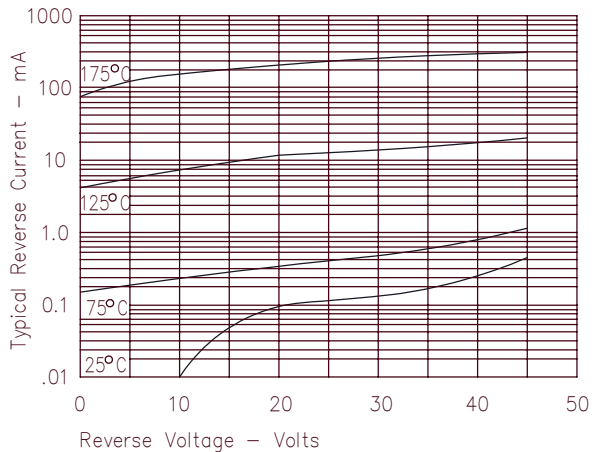

Figure 5
Maximum Forward Power Dissipation — Per Leg

