

NPN Transistors

2SD2457-HF

■ Features

- High collector to emitter voltage V_{CE0} .
- Large collector power dissipation P_C .
- Complementary to 2SB1599-HF
- Pb-Free Package May be Available. The G-Suffix Denotes a Pb-Free Lead Finish

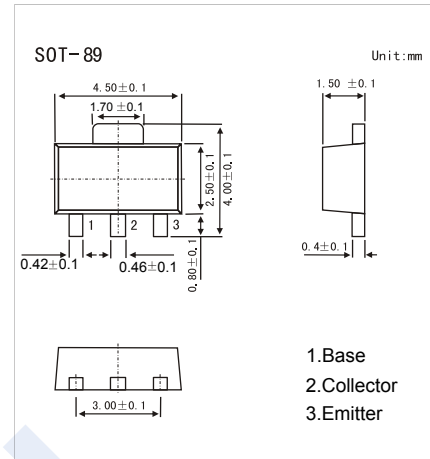

■ Absolute Maximum Ratings $T_a = 25^\circ\text{C}$

Parameter	Symbol	Rating	Unit
Collector - Base Voltage	V_{CB0}	50	V
Collector - Emitter Voltage	V_{CE0}	40	
Emitter - Base Voltage	V_{EB0}	5	
Collector Current - Continuous	I_C	1.5	A
Collector Current - Pulse	I_{CP}	3	
Collector Power Dissipation	P_C	1	W
Junction Temperature	T_J	150	$^\circ\text{C}$
Storage Temperature Range	T_{stg}	-55 to 150	

■ Electrical Characteristics $T_a = 25^\circ\text{C}$

Parameter	Symbol	Test Conditions	Min	Typ	Max	Unit
Collector- base breakdown voltage	V_{CB0}	$I_C = 1 \text{ mA}, I_E = 0$	50			V
Collector- emitter breakdown voltage	V_{CE0}	$I_C = 2 \text{ mA}, I_B = 0$	40			
Emitter - base breakdown voltage	V_{EB0}	$I_E = 1 \text{ mA}, I_C = 0$	5			
Collector-base cut-off current	I_{CBO}	$V_{CB} = 50 \text{ V}, I_E = 0$			1	μA
Collector-emitter cut-off current	I_{CEO}	$V_{CE} = 40 \text{ V}, I_B = 0$			10	
Emitter cut-off current	I_{EBO}	$V_{EB} = 5 \text{ V}, I_C = 0$			0.1	
Collector-emitter saturation voltage	$V_{CE(sat)}$	$I_C = 1.5 \text{ A}, I_B = 150 \text{ mA}$			1	V
Base - emitter saturation voltage	$V_{BE(sat)}$	$I_C = 2 \text{ A}, I_B = 200 \text{ mA}$			1.5	
DC current gain	h_{FE}	$V_{CE} = 5 \text{ V}, I_C = 1 \text{ A}$	80		220	
Collector output capacitance	C_{ob}	$V_{CB} = 20 \text{ V}, I_E = 0, f = 1 \text{ MHz}$		45		pF
Transition frequency	f_T	$V_{CE} = 5 \text{ V}, I_E = -500 \text{ mA}, f = 200 \text{ MHz}$		150		MHz

■ Classification of h_{fe}

Type	2SD2457-Q-HF	2SD2457-R-HF
Range	80-160	120-220
Marking	1YQ _F	1YR _F

NPN Transistors

2SD2457-HF

Typical Characteristics

