

## NPN Transistors

### 2SD1623-HF

#### ■ Features

- Low collector-to-emitter saturation voltage.
- Large current capacity and wide ASO.
- Fast switching speed.
- Complementary to 2SB1123-HF
- Pb-Free Package May be Available. The G-Suffix Denotes a Pb-Free Lead Finish

#### ■ Absolute Maximum Ratings Ta = 25°C

Parameter	Symbol	Rating	Unit
Collector - Base Voltage	V <sub>CB0</sub>	60	V
Collector - Emitter Voltage	V <sub>CEO</sub>	50	
Emitter - Base Voltage	V <sub>EB0</sub>	6	
Collector Current - Continuous	I <sub>C</sub>	2	A
Collector Current - Pulse	I <sub>CP</sub>	4	
Collector Power Dissipation (Note.1)	P <sub>C</sub>	0.5 1.3	W
Junction Temperature	T <sub>J</sub>	150	
Storage Temperature Range	T <sub>stg</sub>	-55 to 150	

Note.1: Mounted on ceramic board (250mm<sup>2</sup> × 0.8mm)

#### ■ Electrical Characteristics Ta = 25°C

Parameter	Symbol	Test Conditions	Min	Typ	Max	Unit
Collector- base breakdown voltage	V <sub>CB0</sub>	I <sub>C</sub> = 100 μA, I <sub>E</sub> = 0	60			V
Collector- emitter breakdown voltage	V <sub>CEO</sub>	I <sub>C</sub> = 1 mA, R <sub>BE</sub> = ∞	50			
Emitter - base breakdown voltage	V <sub>EB0</sub>	I <sub>E</sub> = 100 μA, I <sub>C</sub> = 0	6			
Collector-base cut-off current	I <sub>CB0</sub>	V <sub>CB</sub> = 50 V, I <sub>E</sub> = 0			0.1	μA
Emitter cut-off current	I <sub>EB0</sub>	V <sub>EB</sub> = 4V, I <sub>C</sub> = 0			0.1	
Collector-emitter saturation voltage	V <sub>CE(sat)</sub>	I <sub>C</sub> = 1 A, I <sub>B</sub> = 50 mA		0.15	0.4	V
Base - emitter saturation voltage	V <sub>BE(sat)</sub>	I <sub>C</sub> = 1 A, I <sub>B</sub> = 50 mA		0.9	1.2	
DC current gain	h <sub>FE</sub>	V <sub>CE</sub> = 2V, I <sub>C</sub> = 100 mA	100		560	
		V <sub>CE</sub> = 2V, I <sub>C</sub> = 1.5 A	40			
Turn-ON Time	t <sub>on</sub>	See specified Test Circuit.		60		ns
Storage Time	t <sub>stg</sub>			550		
Fall Time	t <sub>f</sub>			30		
Collector output capacitance	C <sub>ob</sub>	V <sub>CB</sub> = 10V, I <sub>E</sub> = 0, f=1MHz		12		pF
Transition frequency	f <sub>T</sub>	V <sub>CE</sub> = 10V, I <sub>C</sub> = 50mA		150		MHz

#### ■ Classification of h<sub>FE</sub>(1)

Type	2SD1623-R-HF	2SD1623-S-HF	2SD1623-T-HF	2SD1623-U-HF
Range	100-200	140-280	200-400	280-560
Marking	DF R* <sub>F</sub>	DF S* <sub>F</sub>	DF T* <sub>F</sub>	DF U* <sub>F</sub>

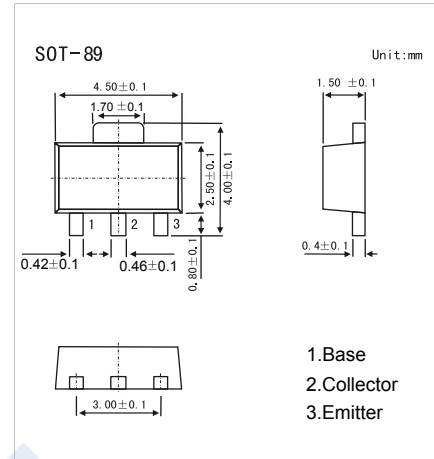

### NPN Transistors

### 2SD1623-HF

#### Switching Time Test Circuit

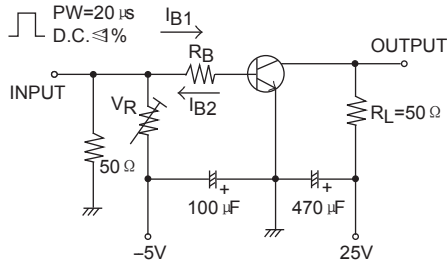

$I_C = 10I_{B1} = -10I_{B2} = 500\text{mA}$   
 (For PNP, the polarity is reversed)

#### Typical Characteristics

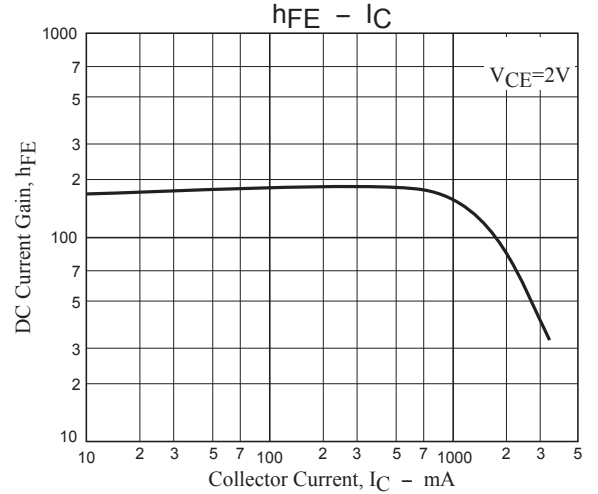
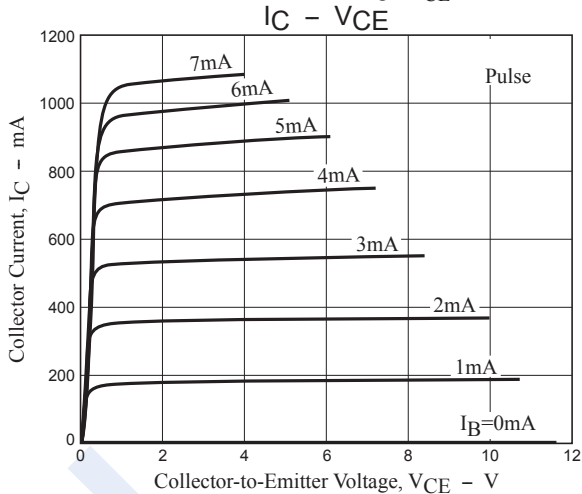
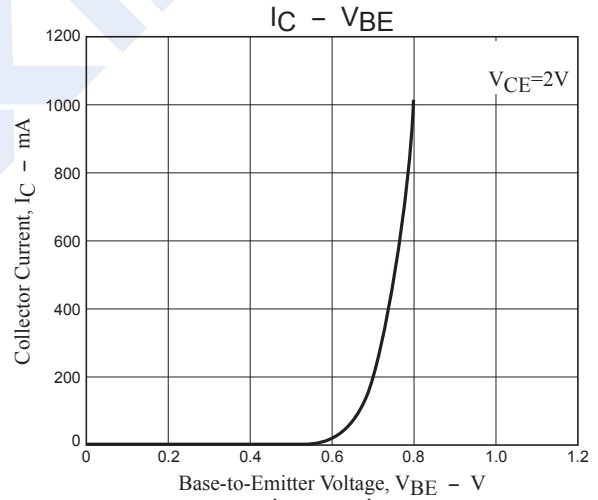
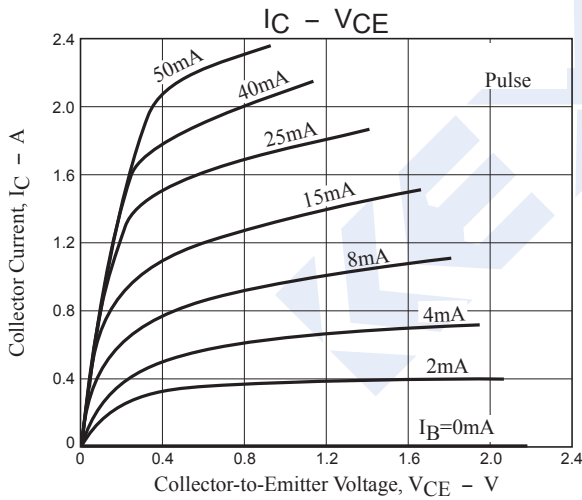

### NPN Transistors

### 2SD1623-HF

■ Typical Characteristics

