

PNP Transistors

2SA1734-HF

■ Features

- Low saturation voltage
- High speed switching time
- Small flat package
- PC = 1.0 to 2.0 W (mounted on a ceramic substrate)
- Complementary to 2SC4539-HF
- Pb-Free Package May be Available. The G-Suffix Denotes a Pb-Free Lead Finish

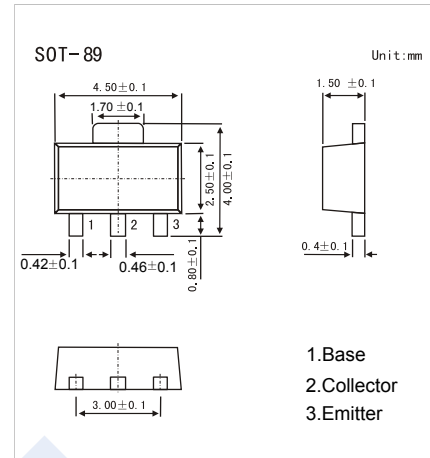

■ Absolute Maximum Ratings Ta = 25°C

Parameter	Symbol	Rating	Unit
Collector - Base Voltage	V _{CB0}	-40	V
Collector - Emitter Voltage	V _{CEO}	-30	
Emitter - Base Voltage	V _{EBO}	-6	
Collector Current - Continuous	I _C	-1.2	A
Base Current	I _B	-0.3	
Collector Power Dissipation (Note.1)	P _C	0.5	W
		1	
Junction Temperature	T _J	150	°C
Storage Temperature range	T _{stg}	-55 to 150	

Note.1: Mounted on ceramic board (250mm² X 0.8mm)

■ Electrical Characteristics Ta = 25°C

Parameter	Symbol	Test Conditions	Min	Typ	Max	Unit
Collector- base breakdown voltage	V _{CB0}	I _C = -1 mA, I _E = 0	-40			V
Collector- emitter breakdown voltage	V _{CEO}	I _C = -10 mA, I _B = 0	-30			
Emitter - base breakdown voltage	V _{EBO}	I _E = -1 mA, I _C = 0	-6			
Collector-base cut-off current	I _{CB0}	V _{CB} = -40 V, I _E = 0			-0.1	uA
Emitter cut-off current	I _{EBO}	V _{EB} = -6 V, I _C = 0			-0.1	
Collector-emitter saturation voltage	V _{CE(sat)}	I _C = -700 mA, I _B = -35 mA			-0.5	V
Base - emitter saturation voltage	V _{BE(sat)}	I _C = -700 mA, I _B = -35 mA			-1.2	
DC current gain	h _{FE(1)}	V _{CE} = -2V, I _C = -100 mA	120		400	
	h _{FE(2)}	V _{CE} = -2V, I _C = -1 A	40			
Turn-on Time	t _{on}	See specified Test Circuit		0.1		us
Storage time	t _{stg}			0.2		
Fall time	t _f			0.1		
Collector output capacitance	C _{ob}	V _{CB} = -10V, I _E = 0, f = 1MHz		16		pF
Transition frequency	f _T	V _{CE} = -2V, I _C = -100 mA		100		MHz

■ Marking

Marking	L*B _F

PNP Transistors

2SA1734-HF

Switching Time Test Circuit

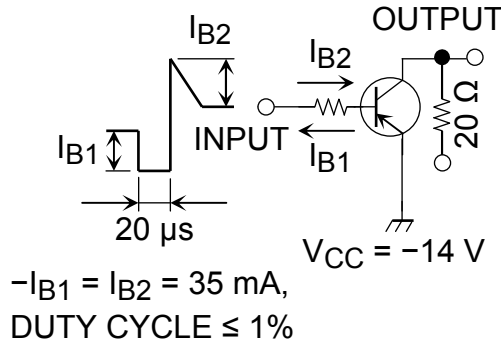

■ Typical Characteristics

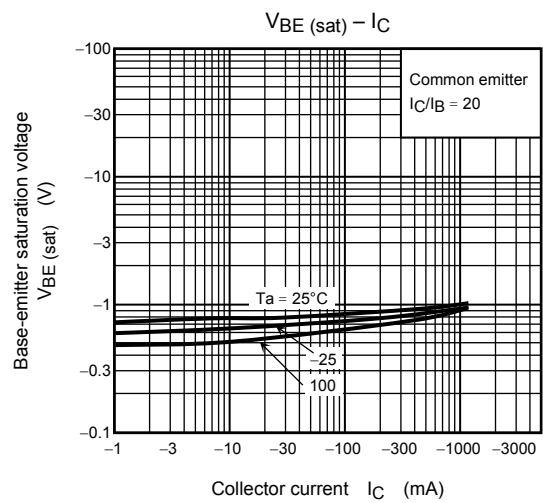
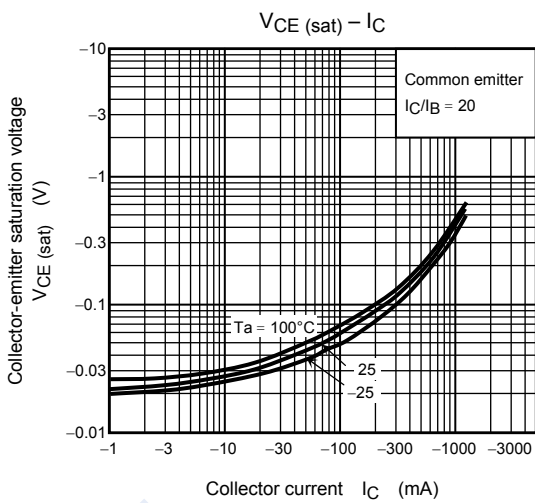
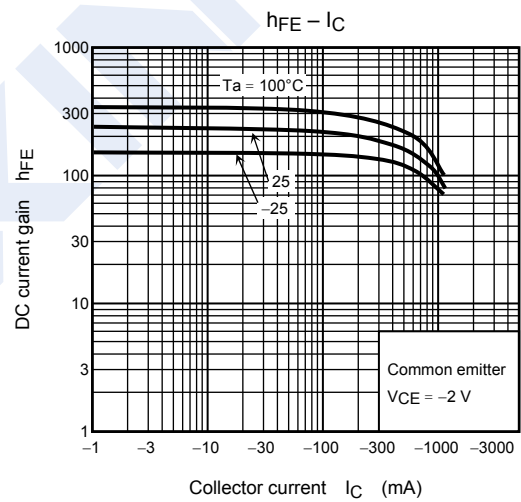
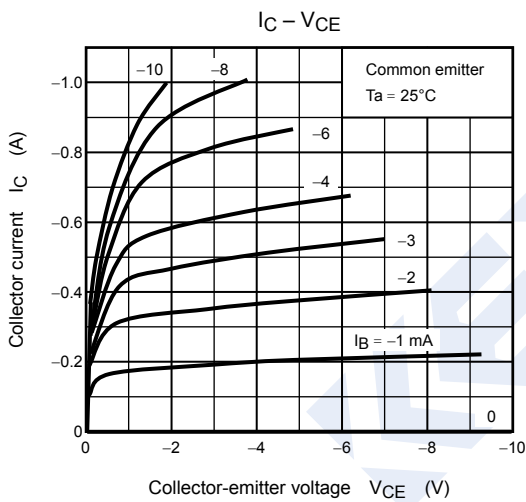

PNP Transistors

2SA1734-HF

Typical Characteristics

