

PNP Transistors

BCP51,BCP52,BCP53

(KCP51,KCP52,KCP53)

■ Features

- For AF driver and output stages
- High collector current
- Low collector-emitter saturation voltage
- Complementary to BCP54,BCP55,BCP56

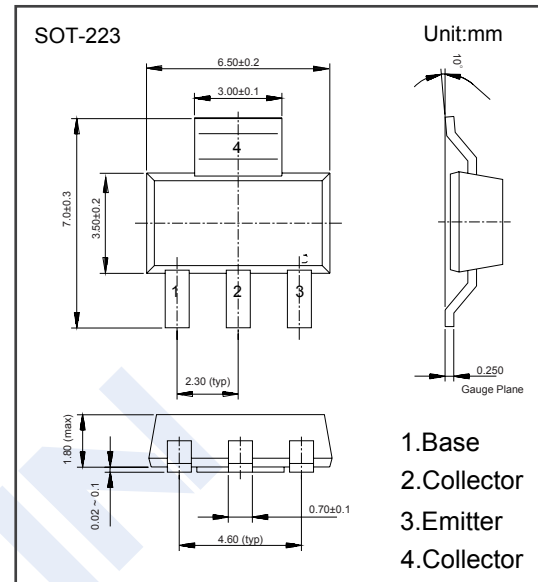

■ Absolute Maximum Ratings Ta = 25°C

Parameter	Symbol	BCP51	BCP52	BCP53	Unit
Collector - Base Voltage	V _{CBO}	-45	-60	-100	V
Collector - Emitter Voltage	V _{CEO}	-45	-60	-80	
Emitter - Base Voltage	V _{EBO}	-5			
Collector Current - Continuous	I _C	-1			A
Collector Power Dissipation	P _C	1.5			W
Thermal Resistance Junction to Ambient	R _{θJA}	94			°C/W
Junction Temperature	T _J	150			°C
Storage Temperature Range	T _{stg}	-65 to 150			

PNP Transistors BCP51,BCP52,BCP53 (KCP51,KCP52,KCP53)

■ Electrical Characteristics Ta = 25°C

Parameter		Symbol	Test Conditions	Min	Typ	Max	Unit
Collector- base breakdown voltage	BCP51	V _{CB0}	I _c = -100 μA, I _E = 0	-45			V
	BCP52			-60			
	BCP53			-100			
Collector- emitter breakdown voltage	BCP51	V _{CE0}	I _c = -10 mA, I _B = 0	-45			V
	BCP52			-60			
	BCP53			-80			
Emitter - base breakdown voltage		V _{EB0}	I _E = -100 μA, I _C = 0	-5			
Collector-base cut-off current	BCP51	I _{CBO}	V _{CB} = -45 V, I _E = 0			-0.1	μA
	BCP52		V _{CB} = -60 V, I _E = 0				
	BCP53		V _{CB} = -100 V, I _E = 0				
Emitter cut-off current		I _{EBO}	V _{EB} = -5V, I _C =0			-0.1	
Collector-emitter saturation voltage		V _{CE(sat)}	I _C =-500 mA, I _B =-50mA			-0.5	V
Base - emitter saturation voltage		V _{BE(sat)}	I _C =-500 mA, I _B =-50mA			-1.2	
Base-emitter voltage		V _{BE}	V _{CE} = -2V, I _C = -500mA			-1	
DC current gain	h _{FE(1)}		V _{CE} = -2V, I _C = -5mA	25			
	h _{FE(2)}		V _{CE} = -2V, I _C = -150mA	63		250	
	h _{FE(3)}		V _{CE} = -2V, I _C = -500mA	25			
Transition frequency		f _T	V _{CE} = -10V, I _C = -50mA,f=100MHz	100			MHz

■ Classification of h_{FE(2)}

TypE	BCP51-10,BCP52-10,BCP53-10	BCP51-16,BCP52-16,BCP53-16
Range	63-160	100-250