

**GLASS PASSIVATED
BRIDGE RECTIFIERS**

REVERSE VOLTAGE - 50 to 1000Volts
FORWARD CURRENT - 25.0 Amperes

FEATURES

- Surge overload rating -350 amperes peak
- Ideal for printed circuit board
- Reliable low cost construction utilizing molded plastic technique
- Plastic material has U/L flammability classification 94V-0
- Mounting position:Any

GBU

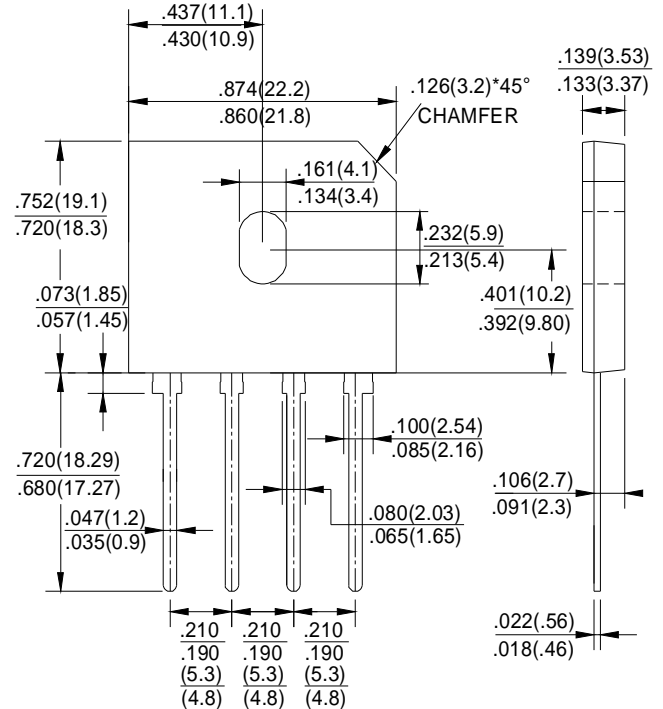

Dimensions in inches and (millimeters)

MAXIMUM RATINGS AND ELECTRICAL CHARACTERISTICS

Rating at 25°C ambient temperature unless otherwise specified.

Single phase, half wave ,60Hz, resistive or inductive load.

For capacitive load, derate current by 20%

CHARACTERISTICS	SYMBOL	GBU 25005	GBU 2501	GBU 2502	GBU 2504	GBU 2506	GBU 2508	GBU 2510	UNIT
Maximum Recurrent Peak Reverse Voltage	V _{RRM}	50	100	200	400	600	800	1000	V
Maximum RMS Voltage	V _{RMS}	35	70	140	280	420	560	700	V
Maximum DC Blocking Voltage	V _{DC}	50	100	200	400	600	800	1000	V
Maximum Average Forward Rectified Current @ T _c =100°C (with heatsink Note 2) @ T _c =100°C (without heatsink)	I _(AV)	25.0 4.2							A
Peak Forward Surge Current 8.3ms Single Half Sine-Wave Super Imposed on Rated Load (JEDEC Method)	I _{FSM}	350							A
Maximum Forward Voltage at 12.5A DC	V _F	1.0							V
Maximum DC Reverse Current at Rated DC Blocking Voltage @ T _J =25°C @ T _J =125°C	I _R	10.0 500							μA
I ² t Rating for Fusing (t<8.3ms)	I ² t	200							A ² s
Typical Junction Capacitance Per Element (Note1)	C _J	70							pF
Typical Thermal Resistance	R _{θJC}	2.2							°C/W
Operating Temperature Range	T _J	-55 to +150							°C
Storage Temperature Range	T _{STG}	-55 to +150							°C

NOTES: 1.Measured at 1.0MHz and applied reverse voltage of 4.0V DC.
2.Device mounted on 100mm*100mm*1.6mm Cu plate heatsink.

FIG.1-MAXIMUM FORWARD SURGE CURRENT

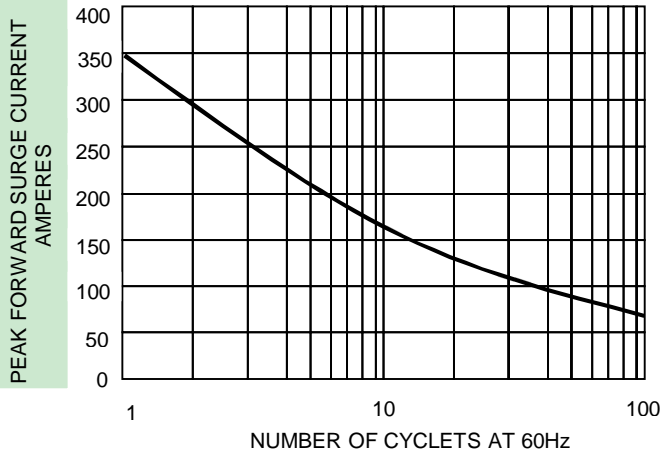

FIG.2- DERATING CURVE
 OUTPUT RECTIFIED CURRENT

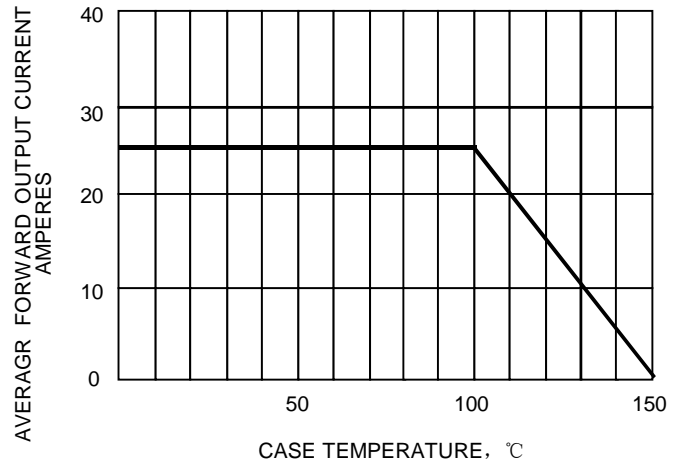

FIG.3-TYPICAL FORWARD
 CHARACTERISTICS

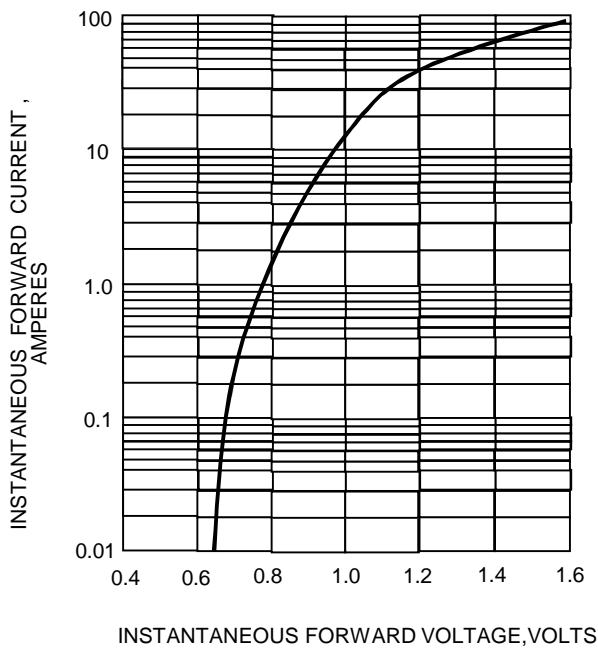

FIG.4-TYPICAL REVERSE
 CHARACTERISTICS

