

GLASS PASSIVATED BRIDGE RECTIFIERS

REVERSE VOLTAGE - 50 to 1000Volts
FORWARD CURRENT - 2.0 Amperes

FEATURES

- Surge overload rating -50 amperes peak
- Ideal for printed circuit board
- Reliable low cost construction utilizing molded plastic technique results in expensive product
- Mounting position :Any

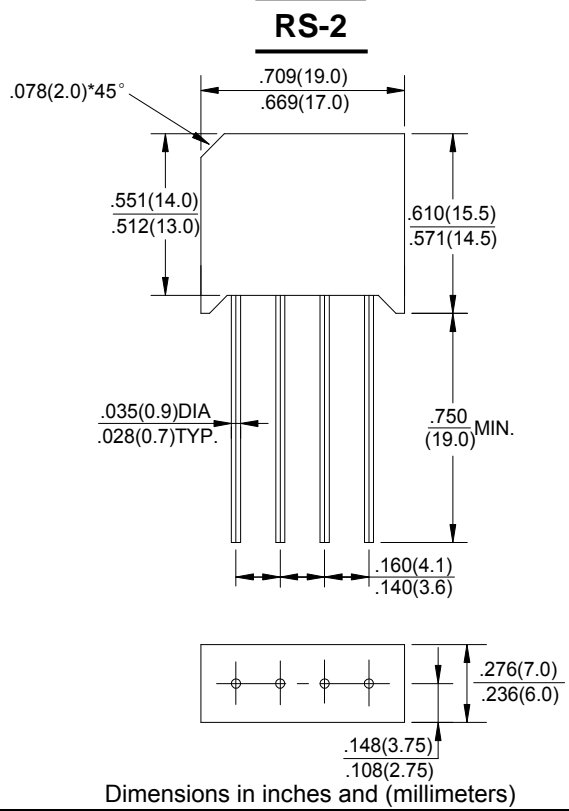

MAXIMUM RATINGS AND ELECTRICAL CHARACTERISTICS

Rating at 25°C ambient temperature unless otherwise specified.

Single phase, half wave ,60Hz, resistive or inductive load.

For capacitive load, derate current by 20%

CHARACTERISTICS	SYMBOL	RS201G	RS202G	RS203G	RS204G	RS205G	RS206G	RS207G	UNIT
Maximum Recurrent Peak Reverse Voltage	V _{RRM}	50	100	200	400	600	800	1000	V
Maximum RMS Voltage	V _{RMS}	35	70	140	280	420	560	700	V
Maximum DC Blocking Voltage	V _{DC}	50	100	200	400	600	800	1000	V
Maximum Average Forward Rectified Current 0.375" (9.5mm) Lead Lengths @T _A =40 °C	I <sub(av)< sub=""></sub(av)<>	2.0							A
Peak Forward Surge Current , 8.3ms Single Half Sine-Wave Super Imposed on Rated Load (JEDEC Method)	I _{FSM}	50							A
I ² t Rating for Fusing (t<8.3ms)	I ² t	15.0							A ² s
Maximum Forward Voltage Drop Per Element at 2.0A Peak	V _F	1.1							V
Maximum DC Reverse Current at Rated DC Blocking Voltage T _J =25°C T _J =100°C	I _R	10.0 1.0							μA mA
Typical Junction Capacitance Per Element (Note1)	C _J	30							pF
Operating Temperature Range	T _J	-55 to +150							°C
Storage Temperature Range	T _{STG}	-55 to +150							°C

Note:1.Measured at 1.0MHz and applied reverse voltage of 4.0V DC.

FIG.1-DERATING CURVE FOR OUTPUT RECTIFIED CURRENT

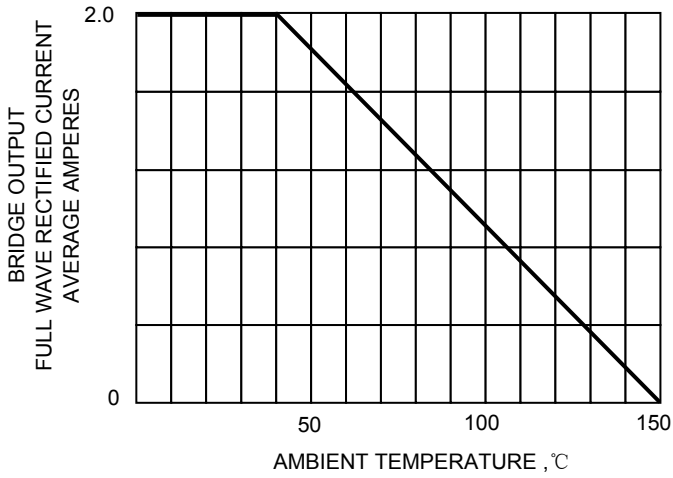

FIG.2-MXIMUM NON-REPETITIVE SURGE CURRENT

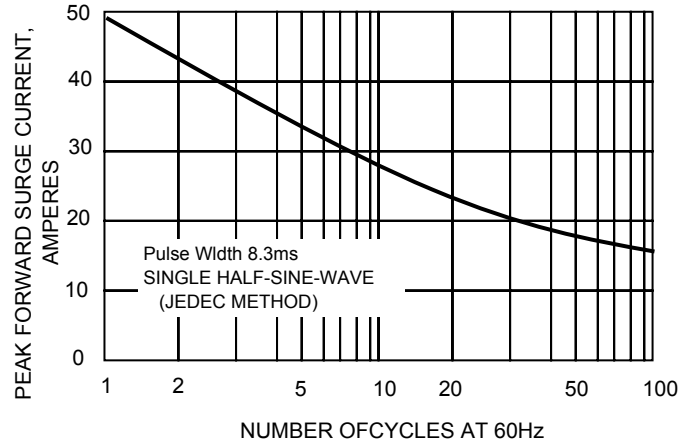

FIG.4-TYPICAL REVERSE CHARACTERISTICS

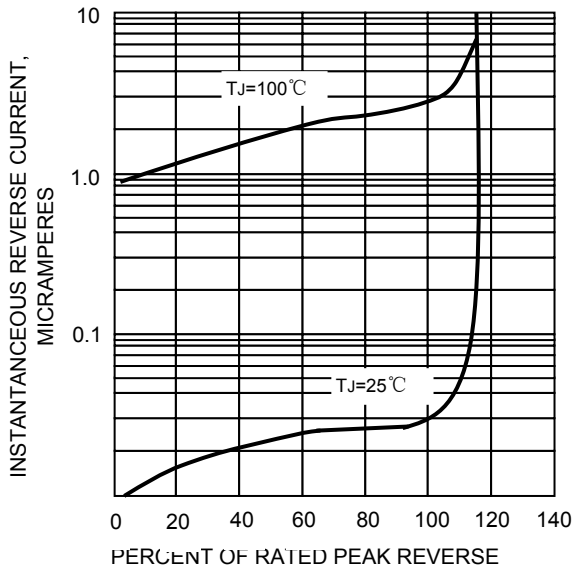

FIG.4-TYPICAL FORWARD CHARACTERISTICS

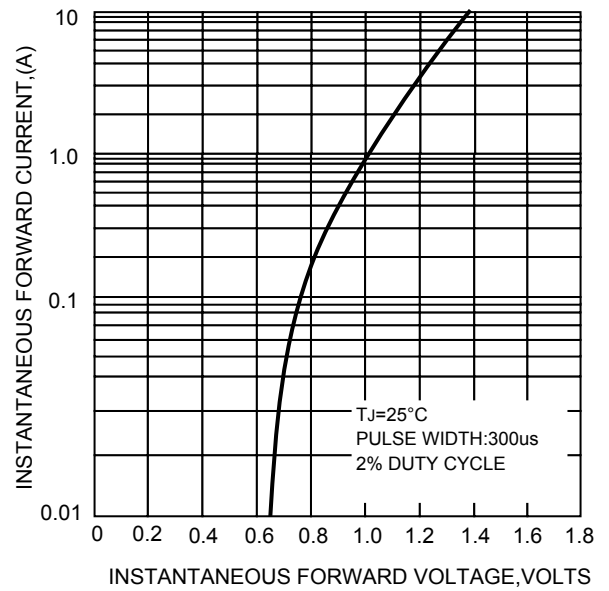

FIG.5-TYPICAL JUNCTION CAPACITANCE PER BRIDGE ELEMENT

