

GLASS PASSIVATED BRIDGE RECTIFIERS

REVERSE VOLTAGE - 50 to 1000Volts
FORWARD CURRENT - 2.0 Amperes

FEATURES

- Rating to 1000V PRV
- Ideal for printed circuit board
- Low forward voltage drop, high current capability
- Reliable low cost construction utilizing molded plastic technique results in inexpensive product
- The plastic material has UL flammability classification 94V-0

MECHANICAL DATA

- Polarity: As marked on Body
- Weight: 0.02 ounces, 0.38 grams
- Mounting position: Any

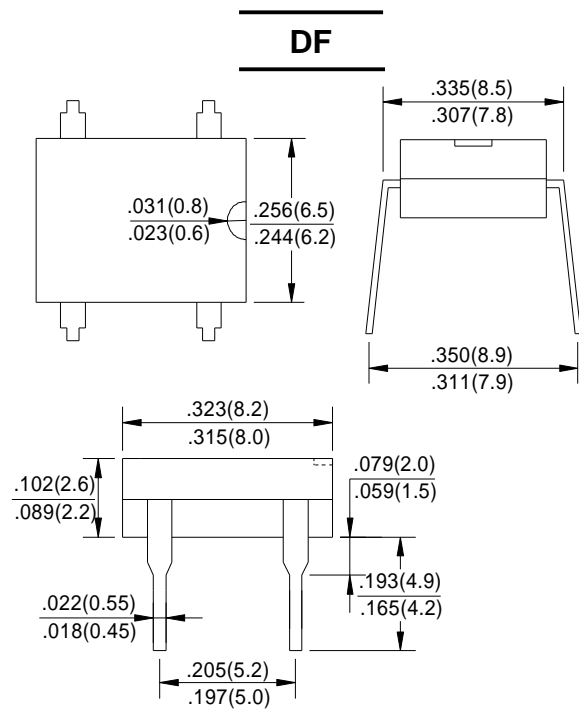

Dimensions in inches and (millimeters)

MAXIMUM RATINGS AND ELECTRICAL CHARACTERISTICS

Rating at 25°C ambient temperature unless otherwise specified.

Single phase, half wave, 60Hz, resistive or inductive load.

For capacitive load, derate current by 20%

| CHARACTERISTICS | SYMBOL | DF 2005 | DF 201 | DF 202 | DF 204 | DF 206 | DF 208 | DF 210 | UNIT |
|---|-------------------|-------------|--------|--------|--------|--------|--------|--------|------------------|
| Maximum Recurrent Peak Reverse Voltage | V _{RRM} | 50 | 100 | 200 | 400 | 600 | 800 | 1000 | V |
| Maximum RMS Voltage | V _{RMS} | 35 | 70 | 140 | 280 | 420 | 560 | 700 | V |
| Maximum DC Blocking Voltage | V _{DC} | 50 | 100 | 200 | 400 | 600 | 800 | 1000 | V |
| Maximum Average Forward Rectified Current @ T _A =40°C | I _(AV) | 2.0 | | | | | | | A |
| Peak Forward Surge Current 8.3ms Single Half Sine-Wave Super Imposed on Rated Load (JEDEC .Method) | I _{FSM} | 60 | | | | | | | A |
| Maximum Forward Voltage at 2.0A DC | V _F | 1.1 | | | | | | | V |
| Maximum DC Reverse Current @ T _J =25°C at Rated DC Blocking Voltage @ T _J =125°C | I _R | 10 500 | | | | | | | μA |
| I ² t Rating for Fusing (t<8.3ms) | I ² t | 10.4 | | | | | | | A ² s |
| Typical Junction capacitance Per Element(Note1) | C _J | 25 | | | | | | | pF |
| Typical Thermal Resistance (Note2) | R _{θJA} | 40 | | | | | | | °C/W |
| Operating Temperature Range | T _J | -55 to +150 | | | | | | | °C |
| Storage Temperature Range | T _{STG} | -55 to +150 | | | | | | | °C |

Note:1.Measured at 1.0MHz and applied reverse voltage of 4.0V DC

2.Thermal resistance from junction to ambient mounted on P.C.B with 0.5*0.5"(13*13mm) copper pads.



FIG.1-DERATING CURVE FOR OUTPUT RECTIFIED CURRENT

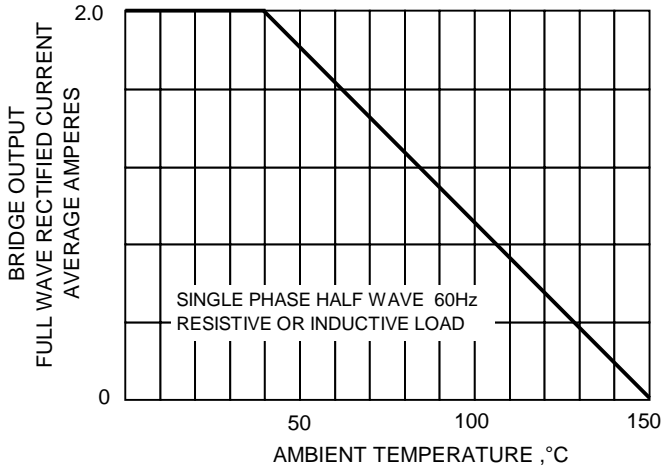

FIG.2-MAXIMUM NON-REPETITIVE PEAK FORWARD SURGE CURRENT

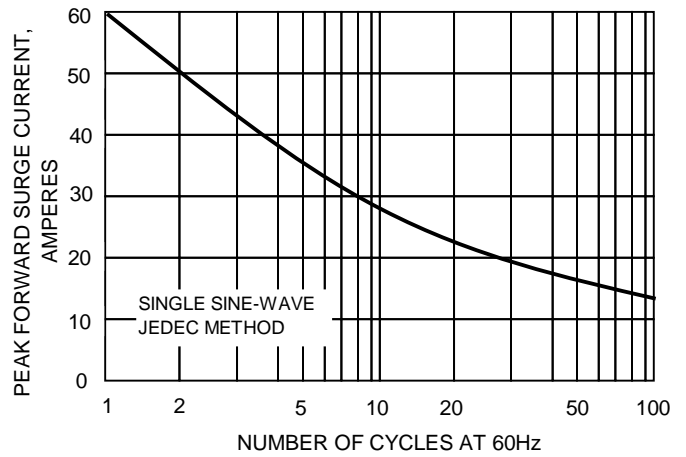

FIG.3-TYPICAL JUNCTION CAPACITANCE

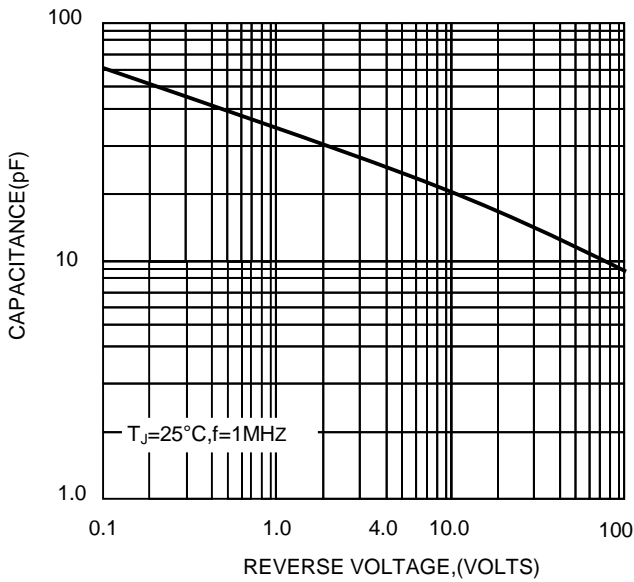

FIG.4-TYPICAL FORWARD CHARACTERISTICS

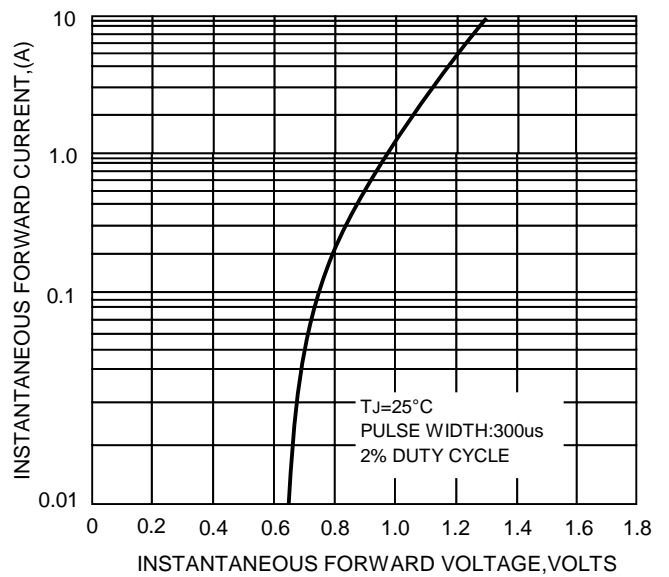

FIG.5-TYPICAL REVERSE CHARACTERISTICS

