

用途：用于一般放大电路。

Purpose: General purpose amplifier.

极限参数/Absolute maximum ratings (Ta=25°C)

参数符号 Symbol	数值 Rating	单位 Unit
V _{CBO}	-60	V
V _{CEO}	-60	V
V _{EB0}	-6.0	V
I _C	-1.0	A
P _C	0.9	W
T _j	150	°C
T _{stg}	-55~150	°C

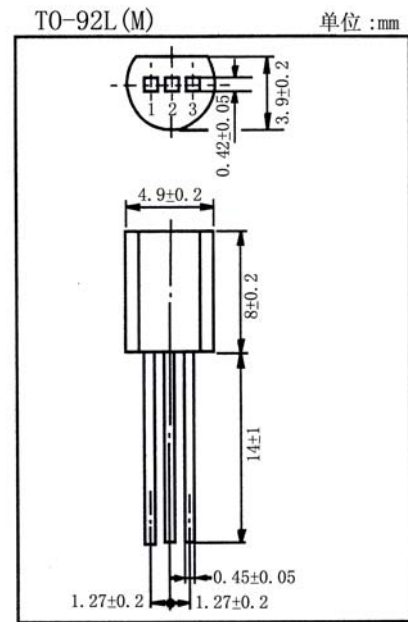

引脚： 1. E 2. C 3. B

电性能参数/Electrical characteristics (Ta=25°C)

参数符号 Symbol	测试条件 Test condition	数值 Rating			单位 Unit
		最小值 Min	典型值 Typ	最大值 Max	
V _{CBO}	I _C =-10 μ A I _E =0	-60			V
V _{CEO}	I _C =-2.0mA I _B =0	-60			V
V _{EB0}	I _E =-10 μ A I _C =0	-6.0			V
I _{CBO}	V _{CB} =-50V I _E =0			-0.2	μ A
I _{EB0}	V _{EB} =-4.0V I _C =0			-0.2	μ A
h _{FE}	V _{CE} =-4.0V I _C =-100mA	60		300	
V _{CE(sat)}	I _C =-500mA I _B =-25mA			-0.3	V
f _T	V _{CE} =-2.0V I _C =-10mA	50			MHz
C _{ob}	V _{CB} =-10V I _E =0 f=1.0MHz			25	pF

h_{FE} 分档/h_{FE} classifications: C:60~120 D:90~180 E:150~300

