



# HER3001PT thru HER3008PT

## HIGH EFFICIENCY GLASS PASSIVATED RECTIFIERS

REVERSE VOLTAGE - 50 to 1000Volts  
FORWARD CURRENT - 30.0 Amperes

### FEATURES

- Low power lose;high efficiency
- Low forward voltage drop
- Low thermal resistance
- High current capability
- High speed switching
- High surge capacity
- High reliability

### MECHANICAL DATA

- Case: TO-3P molded plastic
- Epoxy: UL94V-0 rate flame retardant
- Lead: MIL-STD-202E method 208C guaranteed
- Mounting position :Any
- Weight:5.1grams
- polarity:As marked

### TO-3P

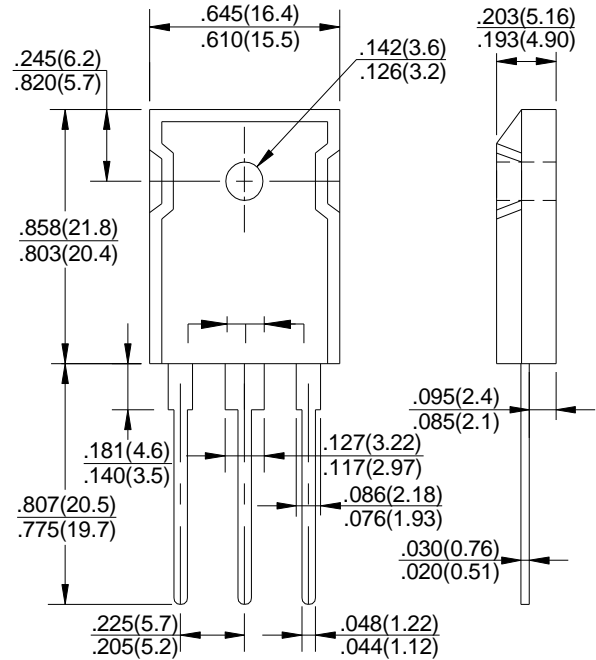

### MAXIMUM RATINGS AND ELECTRICAL CHARACTERISTICS

Rating at 25°C ambient temperature unless otherwise specified.

Single phase, half wave ,60Hz, resistive or inductive load.

For capacitive load, derate current by 20%

CHARACTERISTICS	SYMBOL	HER 3001PT	HER 3002PT	HER 3003PT	HER 3004PT	HER 3005PT	HER 3006PT	HER 3007PT	HER 3008PT	UNIT
Maximum Recurrent Peak Reverse Voltage	V <sub>RRM</sub>	50	100	200	300	400	600	800	1000	V
Maximum RMS Voltage	V <sub>RMS</sub>	35	70	140	210	280	420	560	700	V
Maximum DC Blocking Voltage	V <sub>DC</sub>	50	100	200	300	400	600	800	1000	V
Maximum Average Forward Rectified Current @T <sub>A</sub> =75 °C	I <sub>O</sub>	30								A
Peak Forward Surge Current 8.3ms Single Half Sine-Wave Super Imposed on Rated Load(JEDEC Method)	I <sub>FSM</sub>	300								A
Typical Thermal Resistance	R <sub>θJA</sub>	1.0								°C/W
Typical Junction Capacitance (Note2)	C <sub>J</sub>	125								pF
Peak Forward Voltage at 15.0A DC	V <sub>F</sub>	1.0		1.3		1.7			V	
Maximum DC Reverse Current @T <sub>J</sub> =25°C at Rated DC Blocking Voltage @T <sub>J</sub> =100°C	I <sub>R</sub>	10				150			μA	
Maximum Reverse Recovery Time(Note1)	T <sub>RR</sub>	60								nS
Operating and Storage Temperature Range	T <sub>J</sub> ,T <sub>STG</sub>	-55 to + 150								°C

NOTES:1.Measured with I<sub>F</sub>=0.5A,I<sub>R</sub>=1A,I<sub>RR</sub>=0.25A

2.Measured at 1.0 MHZ and applied reverse voltage of 4.0VDC.

FIG.1- TYPICAL FORWARD CURRENT DERATING CURVE

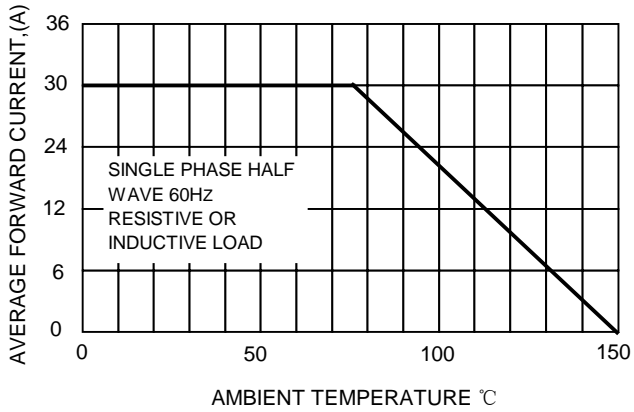

FIG.2-TYPICAL REVERSE CHARACTERISTICS

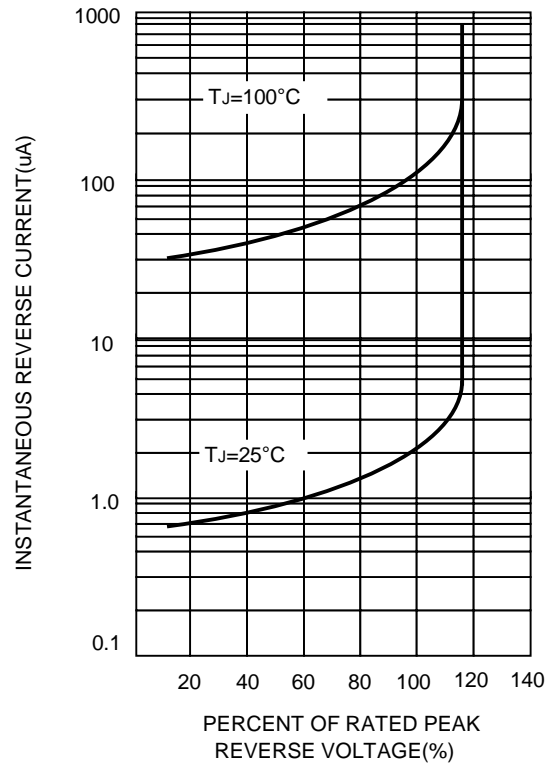

FIG.3-MAXIMUM NON-REPETITIVE FORWARD SURGE CURRENT

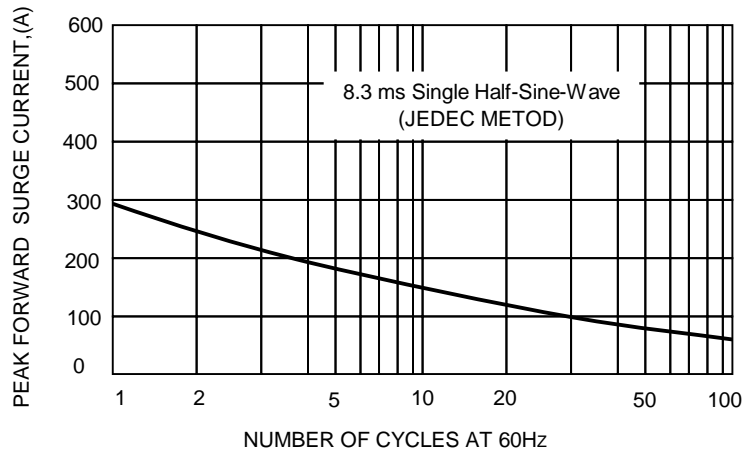

FIG.4-TYPICAL INSTANTANEOUS FORWARD CHARACTERISTICS

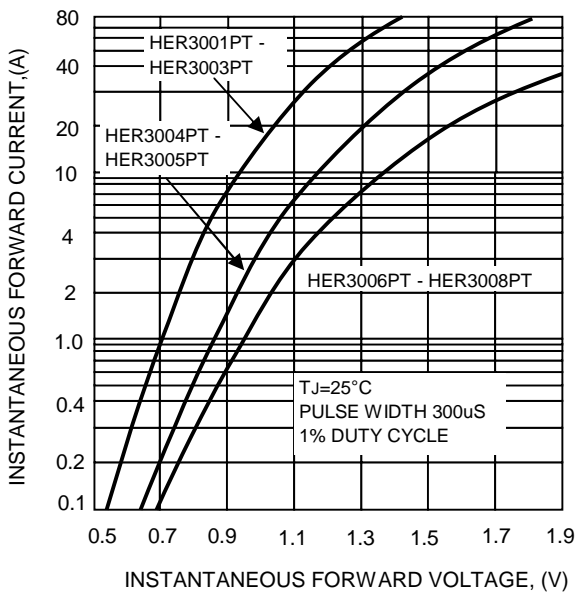

FIG.5-TYPICAL JUNCTION CAPACITANCE

