

100V / 125A
N-Channel Enhancement Mode MOSFET

100V, $R_{DS(ON)}=5.8m\Omega @ V_{GS}=10V, I_D=40A$

Features

- Low On-State Resistance
- Excellent Gate Charge x $R_{DS(ON)}$ Product (FOM)
- Fully Characterized Avalanche Voltage and Current
- Specially Designed for DC-DC Converter, Off-line UPS, Automotive System, Solenoid and Motor Control
- In compliance with EU RoHs 2002/95/EC Directives

TO-220AB

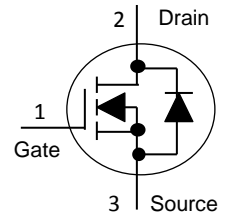
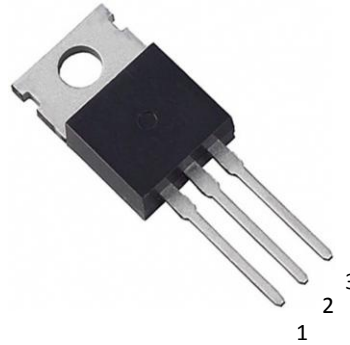

Mechanical Information

- Case: TO-220AB Molded Plastic
- Terminals : Solderable per MIL-STD-750, Method 2026

Marking & Ordering Information

TYPE	MARKING	PACKAGE	PACKING
HY125N10T	125N10T	TO-220AB	50PCS/TUBE

Absolute Maximum Ratings ($T_C=25^\circ C$ unless otherwise specified)

Parameter	Symbol	Value	Units
Drain-Source Voltage	V_{DS}	100	V
Gate-Source Voltage	V_{GS}	± 20	V
Continuous Drain Current ¹⁾	I_D	120	A
Pulsed Drain Current ¹⁾	I_{DM}	480	A
Maximum Power Dissipation Derating Factor	P_D	192 1.28	W
Avalanche Energy with Single Pulse, $L=0.3mH$	E_{AS}	1250	mJ
Operating Junction and Storage Temperature Range	T_J, T_{STG}	-55 to +175	$^\circ C$

Note : 1. Maximum DC current limited by the package

Thermal Characteristics

Parameter	Symbol	Value	Units
Junction-to-Case Thermal Resistance	$R_{\theta JC}$	0.78	$^\circ C/W$
Junction-to-Ambient Thermal Resistance	$R_{\theta JA}$	62.5	$^\circ C/W$

COMPANY RESERVES THE RIGHT TO IMPROVE PRODUCT DESIGN · FUNCTIONS AND RELIABILITY WITHOUT NOTICE

Electrical Characteristics ($T_C=25$, Unless otherwise noted)

Parameter	Symbol	Test Condition	Min.	Typ.	Max.	Units
Static						
Drain-Source Breakdown Voltage	BV_{DSS}	$V_{GS}=0V \cdot I_D=250\mu A$	100	-	-	V
Gate Threshold Voltage	$V_{GS(th)}$	$V_{DS}=V_{GS} \cdot I_D=250\mu A$	2	3	4	V
Drain-Source On-State Resistance	$R_{DS(on)}$	$V_{GS}=10V \cdot I_D=80A$	-	4.6	5.8	m Ω
Zero Gate Voltage Drain Current	I_{DSS}	$V_{DS}=80V \cdot V_{GS}=0V$	-	-	1	μA
Gate Body Leakage Current	I_{GSS}	$V_{GS}=\pm 20V \cdot V_{DS}=0V$	-	-	100	nA
Dynamic						
Total Gate Charge	Qg	$V_{DS}=50V \cdot I_D=40A$ $V_{GS}=10V$	-	178	-	nC
Gate-Source Charge	Qgs		-	32	-	
Gate-Drain Charge	Qgd		-	45	-	
Turn-On Delay Time	$t_{d(on)}$	$V_{DD}=50V \cdot I_D=40A$ $V_{GS}=10V \cdot R_G=3.6\Omega$	-	31.8	-	ns
Turn-On Rise Time	t_r		-	19.2	-	
Turn-Off Delay Time	$t_{d(off)}$		-	76	-	
Turn-Off Fall Time	t_f		-	52	-	
Input Capacitance	C_{iss}	$V_{DS}=30V \cdot V_{GS}=0V$ $f=1.0MHz$	-	9200	-	pF
Output Capacitance	C_{oss}		-	680	-	
Reverse Transfer Capacitance	C_{riss}		-	320	-	
Gate Resistance	Rg		-	1.3	-	Ω
Source-Drain Diode						
Max. Diode Forward Voltage	I_S	-	-	-	120	A
Diode Forward Voltage	V_{SD}	$I_S=80A \cdot V_{GS}=0V$	-	0.86	1.4	V
Reverse Recovery Time	t_{rr}	$V_{GS}=0V \cdot I_S=40A$ $di/dt=100A/\mu s$	-	72	-	ns
Reverse Recovery Charge	Q_{rr}		-	210	-	μC

NOTE : Pulse Test : Pulse Width $\leq 300\mu s$, duty cycle $\leq 2\%$

Typical Characteristics Curves ($T_c=25^\circ\text{C}$, unless otherwise noted)

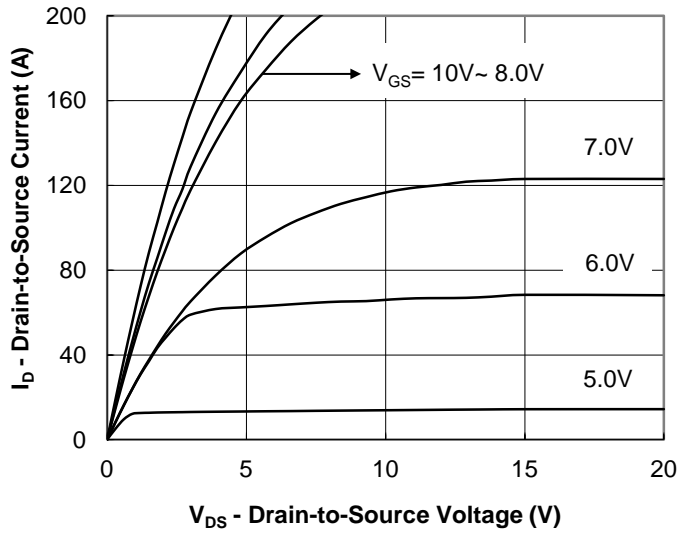

Fig.1 Output Characteristic

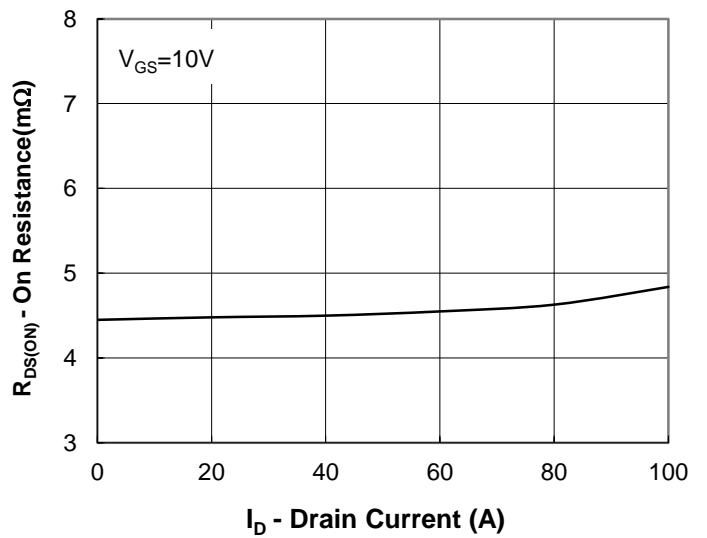

Fig.2 On-Resistance vs Drain Current

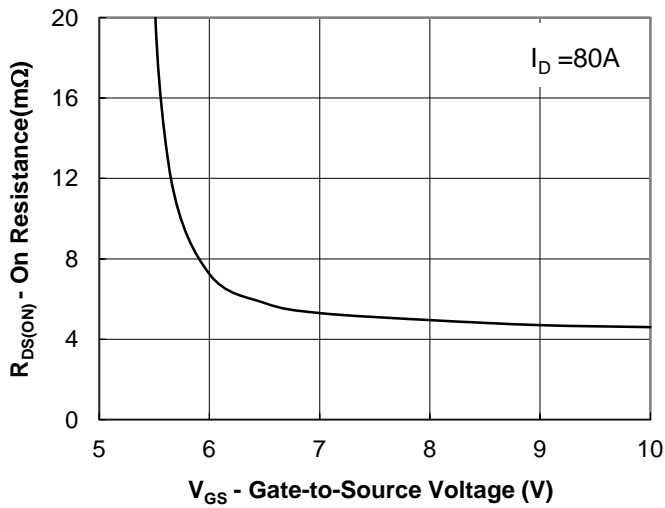

Fig.3 On-Resistance vs Gate to Source Voltage

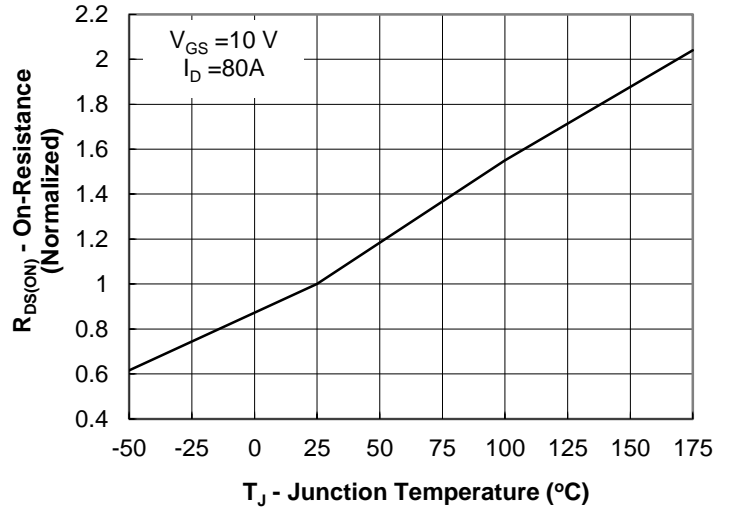

Fig.4 On-Resistance vs Junction Temperature

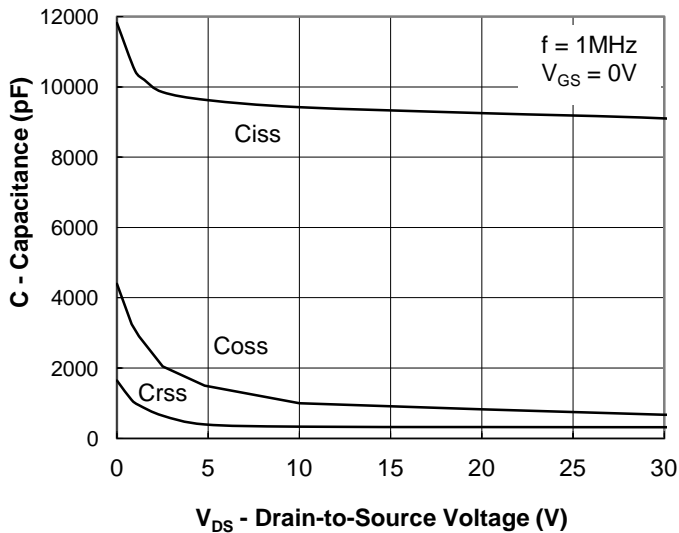

Fig.5 Capacitance Characteristic

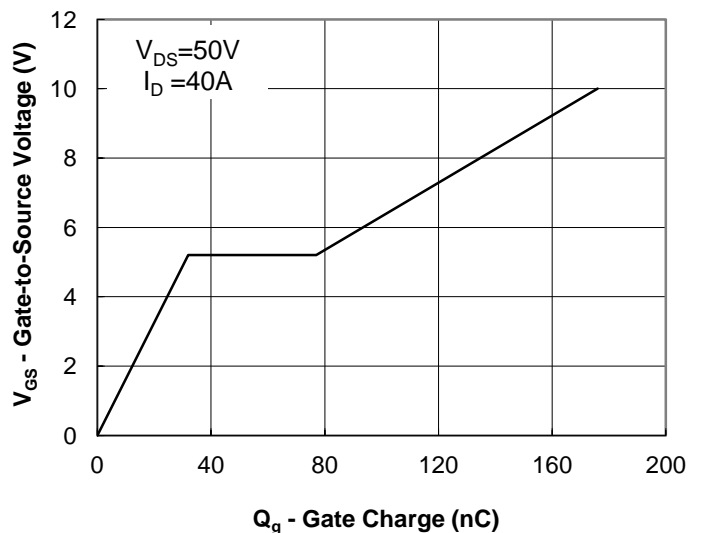

Fig.6 Gate Charge Characteristic

Typical Characteristics Curves ($T_C=25^\circ\text{C}$, unless otherwise noted)

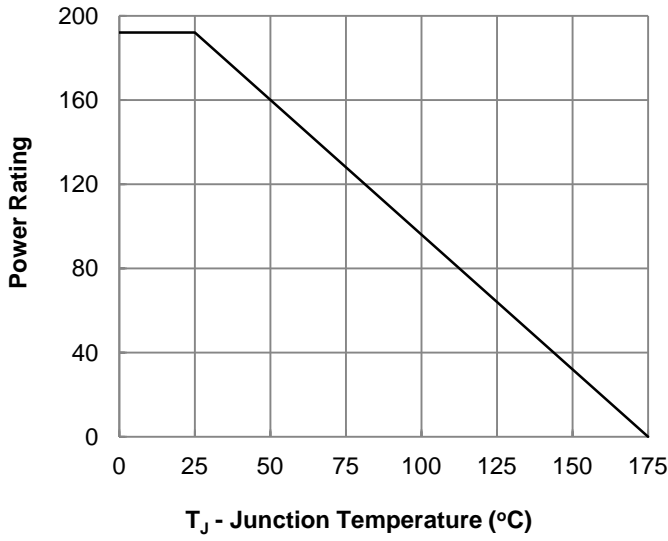

Fig.7 Power Derating Curve

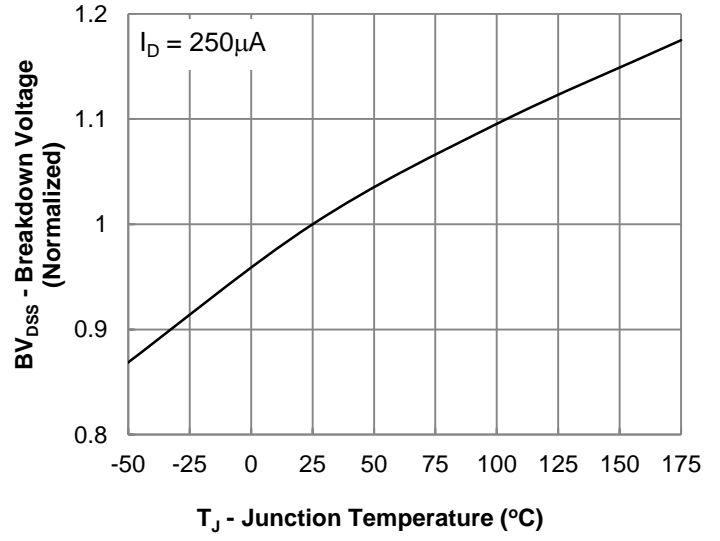

Fig.8 Breakdown Voltage vs Junction Temperature

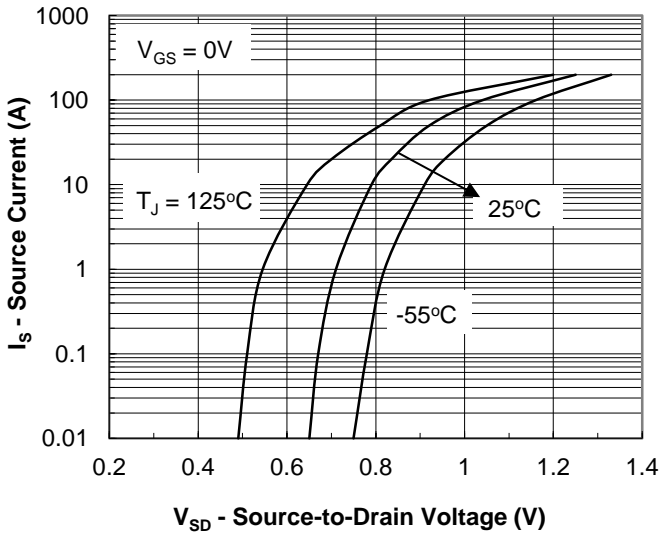

Fig.9 Body Diode Forward Voltage Characteristic