

用途:用于功率放大和帧频输出。

Purpose: Power amplifier applications, vertical output applications.

特点:于 2SC2073A (3DA2073A) 互补。

Features: Complementary to 2SC2073A (3DA2073A).

极限参数/Absolute maximum ratings (Ta=25°C)

参数符号 Symbol	数值 Rating	单位 Unit
V _{CB0}	-150	V
V _{CE0}	-150	V
V _{EB0}	-5.0	V
I _C	-1.5	A
I _B	-0.5	A
P _C	2.0	W
P _C (T _c =25°C)	25	W
T _j	150	°C
T _{stg}	-55~150	°C

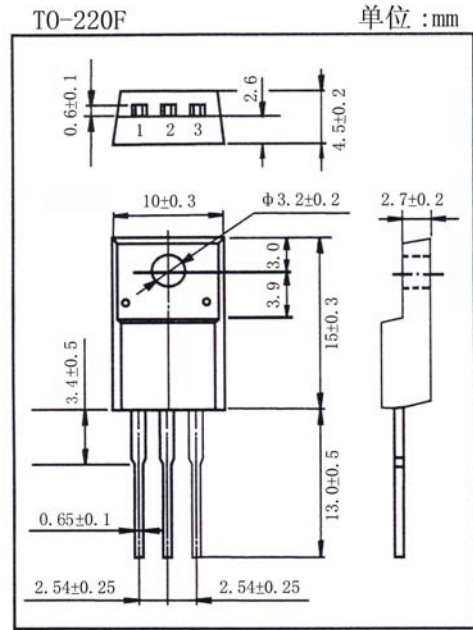

引脚: 1. B 2. C 3. E

电性能参数/Electrical characteristics (Ta=25°C)

参数符号 Symbol	测试条件 Test condition	数值 Rating			单位 Unit
		最小值 Min	典型值 Typ	最大值 Max	
I _{CB0}	V _{CB} =-120V I _E =0			-10	μ A
I _{EB0}	V _{EB} =-5.0V I _C =0			-10	μ A
h _{FE}	V _{CE} =-10V I _C =-500mA	40	75	140	
V _{CE(sat)}	I _C =-500mA I _B =-50mA			-1.5	V
V _{BE}	V _{CE} =-10V I _C =-500mA	-0.65	-0.75	-0.85	V
f _T	V _{CE} =-10V I _C =-500mA		4.0		MHz
C _{ob}	V _{CB} =-10V I _E =0 f=1.0MHz		55		pF



2SA940A (3CA940A)

