

用途:用于音频功率放大和驱动/Purpose:AF power amplifier and driver.

特点:与 2SC1383 (3DA1383) 互补/Features:Complementary pair with 2SC1383 (3DA1383).

极限参数/Absolute Maximum Ratings(Ta=25°C)

参数符号 Symbol	数值 Rating	单位 Unit
V _{CBO}	-30	V
V _{CEO}	-25	V
V _{EBO}	-5.0	V
I _C	-1.0	A
I _{CP}	-1.5	A
P _C	1.0	W
T _j	150	°C
T _{stg}	-55~150	°C

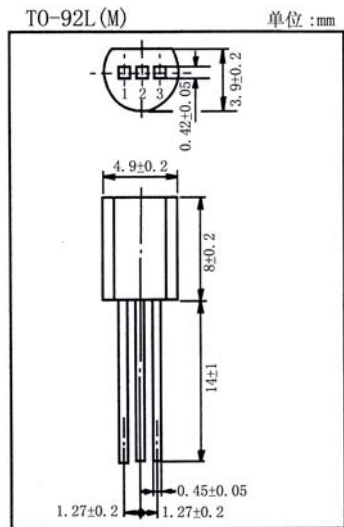

引脚: 1.E 2.C 3.B

电性能参数/Electrical Characteristics(Ta=25°C)

参数符号 Symbol	测试条件 Test Condition	数值 Rating			单位 Unit
		最小值 Min	典型值 Typ	最大值 Max	
V _{CBO}	I _C =-10 μA I _E =0	-30			V
V _{CEO}	I _C =-2.0mA I _B =0	-25			V
V _{EBO}	I _E =-10 μA I _C =0	-5.0			V
I _{CBO}	V _{CB} =-20V I _E =0			-0.1	μA
h _{FE(1)}	V _{CE} =-10V I _C =-500mA	85		340	
h _{FE(2)}	V _{CE} =-5.0V I _C =-1.0A	50			
V _{CE(sat)}	I _C =-500mA I _B =-50mA		-0.2	-0.4	V
V _{BE(sat)}	I _C =-500mA I _B =-50mA		-0.85	-1.2	V
f _T	V _{CE} =-10V I _C =-50mA		200		MHz
C _{ob}	V _{CB} =-10V I _E =0 f=1.0MHz		20	30	pF

h_{FE(1)} 分档/h_{FE(1)} Classifications: Q:85~170 R:120~240 S:170~340

