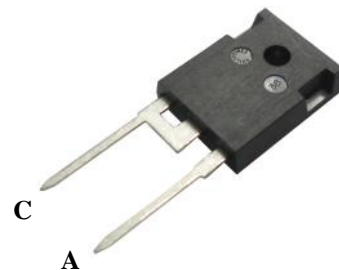


PRELIMINARY DATASHEET
**Fast Recovery 30A, 600V Epitaxial Diodes,
 in TO247 B1 version**
APPLICATIONS

- Freewheeling diode (FWD)
- Snubber diode
- Clamp diode
- Power factor correction (PFC)
- Plating power supply
- Ultrasonic cleaner and welder
- Converter and chopper
- Uninterruptible power supplies
- High speed rectifiers
- Inductive heating and melting applications


FEATURES

- Ultrafast recovery time
- Soft recovery characteristics
- Low recovery loss
- Low forward voltage
- High surge current capability
- Low leakage current
- Pb-free finished; **RoHS compliant**


MAXIMUM RATINGS

Parameter	Symbol	Value	Units
Repetitive peak reverse voltage	V_{RRM}	600	V
Average forward current $T_c = 110^\circ\text{C}$	$I_{F(AV)}$	30	A
Surge non-repetitive forward current $T_j = 45^\circ\text{C}$, $t_p = 10$ ms, 50Hz, Sine	I_{FSM}	300	
Operating junction and storage temperature	T_j, T_{stg}	-40... +150	$^\circ\text{C}$

Thermal Characteristics

Parameter	Symbol	Max. Value	Units
Characteristics			
Thermal resistance, junction to case	R_{thJC}	0.8	$^\circ\text{C}/\text{W}$

Electrical Characteristics, at $T_j = 25^\circ\text{C}$, unless otherwise specified

Parameter	Symbol	Value			Unit
		Min.	Typ.	Max.	
Static Characteristics					
Reverse leakage current $V_R = 600\text{V}$ $V_R = 600\text{V}$, $T_j = 125^\circ\text{C}$	I_R	-	-	15 250	μA
Forward voltage drop $I_F = 30\text{A}$, $T_j = 25^\circ\text{C}$ $I_F = 30\text{A}$, $T_j = 125^\circ\text{C}$	V_F	-	1.4 1.1	2.0 -	V

Electrical Characteristics, at $T_j = 25^\circ\text{C}$, unless otherwise specified

Parameter	Symbol	Value			Unit
		Min.	Typ.	Max.	
Dynamic Characteristics					
Reverse recovery time $V_R = 30\text{V}$, $I_F = 1\text{A}$, $di_F/dt = -200\text{A}/\mu\text{s}$ $V_R = 300\text{V}$, $I_F = 30\text{A}$, $di_F/dt = -200\text{A}/\mu\text{s}$, $T_j = 25^\circ\text{C}$ $V_R = 300\text{V}$, $I_F = 30\text{A}$, $di_F/dt = -200\text{A}/\mu\text{s}$, $T_j = 125^\circ\text{C}$	t_{rr}	-	25 102 166	-	ns
Reverse recovery charge $V_R = 300\text{V}$, $I_F = 30\text{A}$, $di_F/dt = -200\text{A}/\mu\text{s}$, $T_j = 25^\circ\text{C}$ $V_R = 300\text{V}$, $I_F = 30\text{A}$, $di_F/dt = -200\text{A}/\mu\text{s}$, $T_j = 125^\circ\text{C}$	Q_{rr}	-	206 1434	-	nC
Maximum reverse recovery current $V_R = 300\text{V}$, $I_F = 30\text{A}$, $di_F/dt = -200\text{A}/\mu\text{s}$, $T_j = 25^\circ\text{C}$ $V_R = 300\text{V}$, $I_F = 30\text{A}$, $di_F/dt = -200\text{A}/\mu\text{s}$, $T_j = 125^\circ\text{C}$	I_{rrm}	-	5.9 13.5	-	A

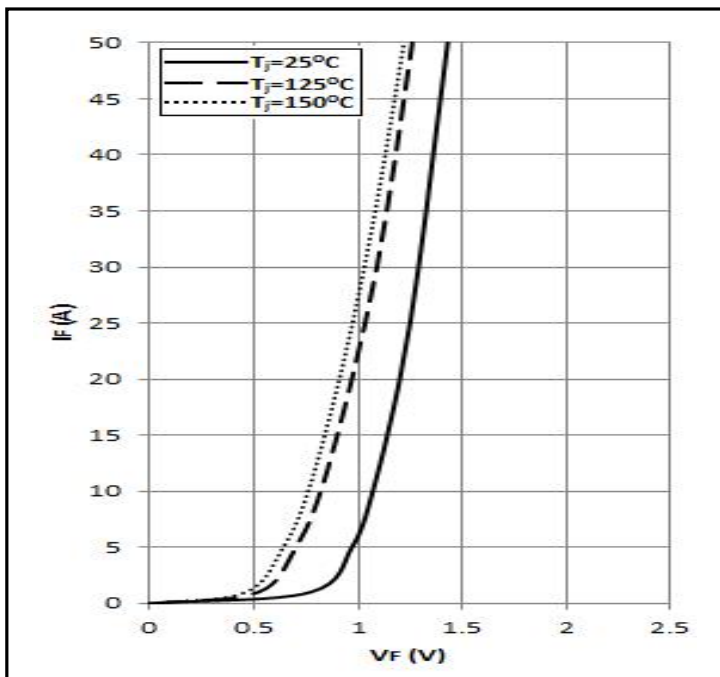
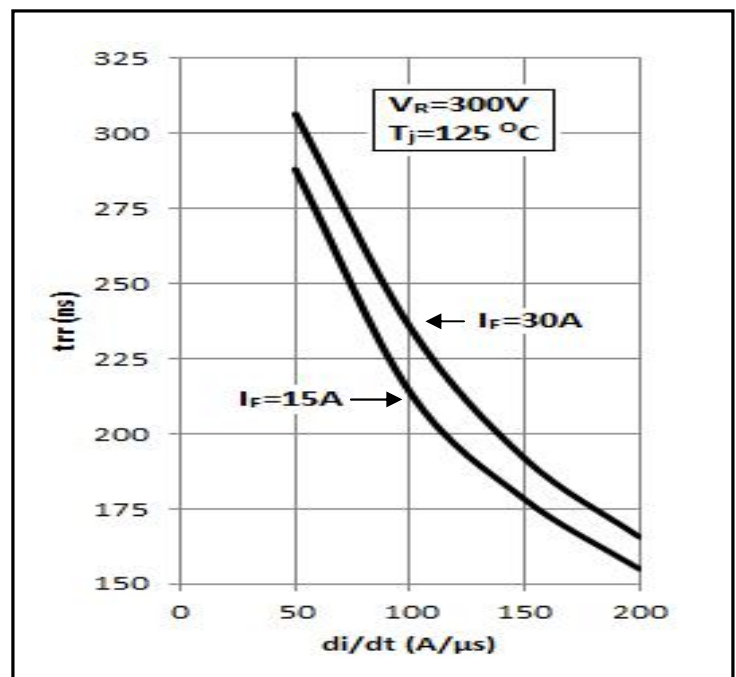
Figure 1 – Typical Forward voltage drop vs forward current

Figure 2 – Reverse recovery time vs di_F/dt


Figure 3 – Reverse recovery charge vs di_F/dt

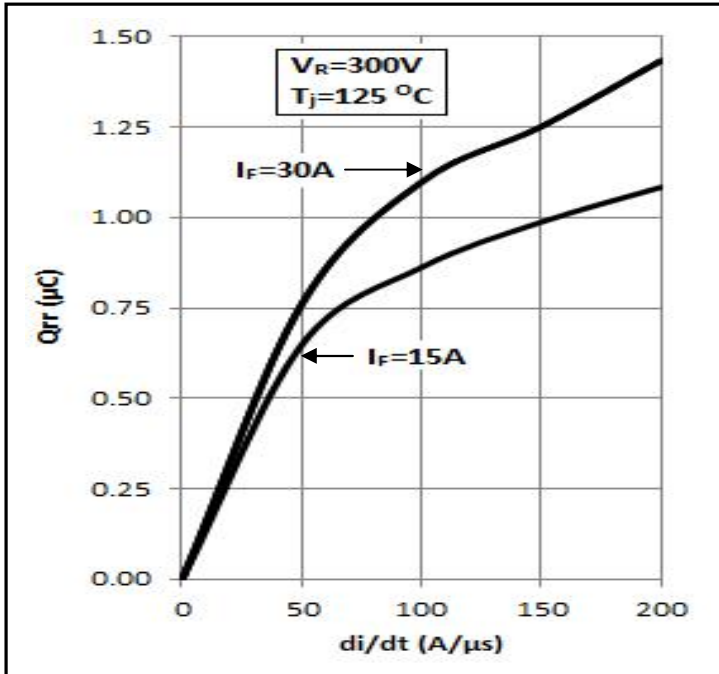


Figure 4 – Reverse recovery current vs di_F/dt

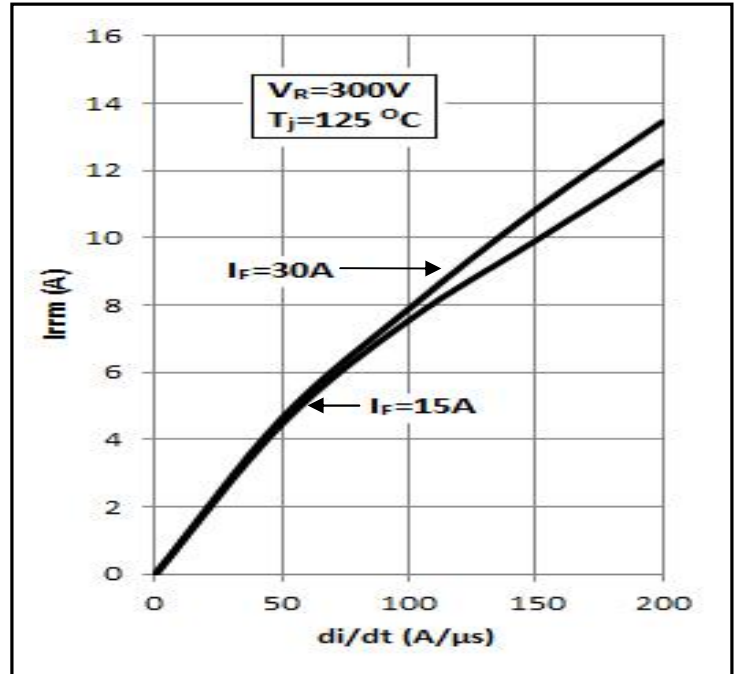
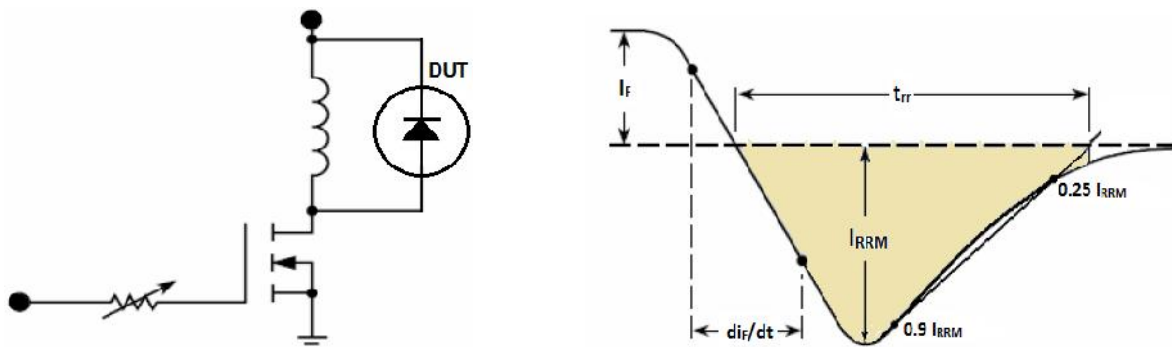
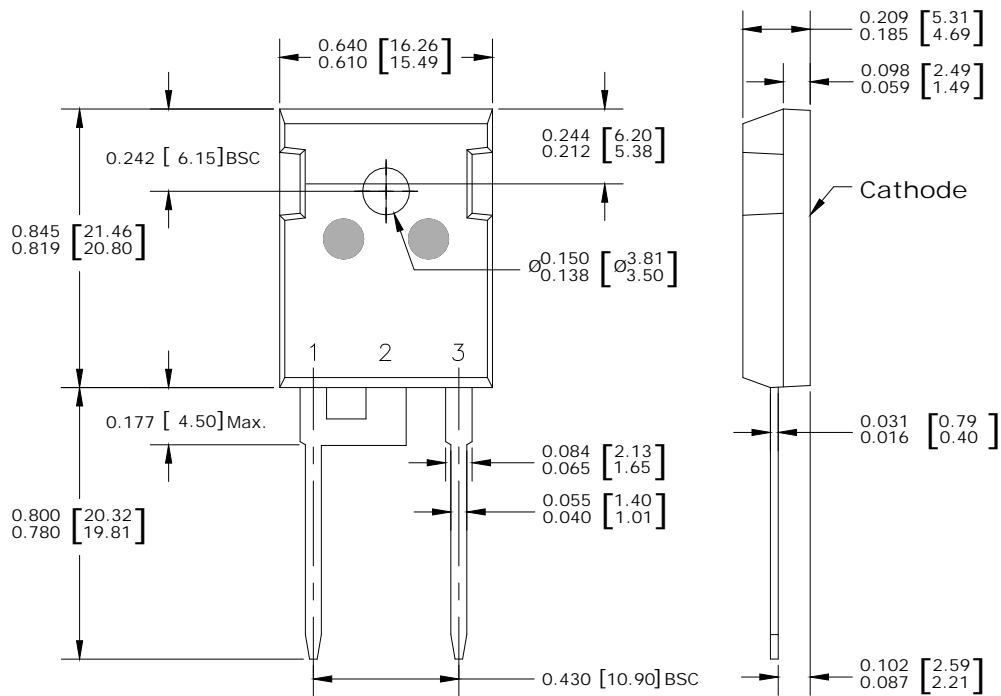


Figure 5 – Diode Reverse Recovery Test Circuit and Waveform



Package Outline Drawing



Disclaimer

These specifications may not be considered as a guarantee of components characteristics. Components have to be tested depending on intended application as adjustments may be necessary. The use of **iQXPRZ Power Inc.** components in life support appliances and systems are subject to written approval of **iQXPRZ Power Inc.**