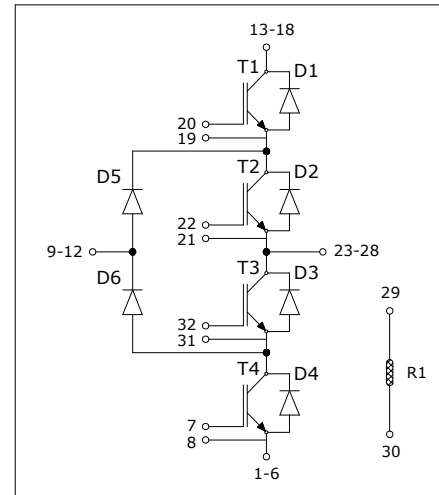

**PRELIMINARY DATASHEET**
**Three Level Inverter Power Module  
Trench + Field Stop IGBT**

- Low voltage drop
- Low tail current
- Very tight parameter distribution
- High ruggedness, temperature stability
- Very soft, fast recovery anti-parallel diode
- Pb-free finished; RoHS compliant

**MAXIMUM RATINGS (IGBT), at  $T_j = 25^\circ\text{C}$ , unless otherwise specified**

Parameter	Symbol	Value	Units
Collector-emitter voltage	$V_{CE}$	600	V
DC collector current, limited by $T_{jmax}$ $T_C = 80^\circ\text{C}$	$I_C$	100	A
Pulsed collector current, $t_p$ limited by $T_{jmax}$	$I_{Cpulse}$	200	
Gate-emitter voltage	$V_{GE}$	$\pm 20$	V
Power dissipation $T_C = 25^\circ\text{C}$	$P_D$	335	W
Thermal resistance, junction to case	$R_{thJC}$	0.45	K/W

**ELECTRICAL CHARACTERISTICS (IGBT), at  $T_j = 25^\circ\text{C}$ , unless otherwise specified**

Parameter	Symbol	Conditions	Value			Unit
			Min.	Typ.	Max.	
Collector-emitter saturation voltage $T_j = 25^\circ\text{C}$ $T_j = 150^\circ\text{C}$	$V_{CE(sat)}$	$V_{GE} = 15\text{V}, I_C = 100\text{A}$	-	1.45 1.70	1.9	V
Gate-emitter threshold voltage	$V_{GE(th)}$	$I_C = 1.6\text{mA}, V_{CE} = V_{GE}$	4.9	5.8	6.5	V
Zero gate voltage collector current	$I_{CES}$	$V_{CE} = 600\text{V}, V_{GE} = 0$	-	-	1.0	mA
Gate-emitter leakage current	$I_{GES}$	$V_{CE} = 0\text{V}, V_{GE} = 20\text{V}$	-	-	100	nA
Input capacitance	$C_{iss}$	$V_{CE} = 25\text{V},$ $V_{GE} = 0\text{V},$ $f = 1\text{MHz}$	-	6200	-	pF
Output capacitance	$C_{oss}$		-	384	-	
Reverse transfer capacitance	$C_{rss}$		-	190	-	
Gate charge	$Q_{Gate}$	$V_{GE} = 15\text{V}$	-	1000	-	nC
Turn-on delay time (inductive load) $T_j = 25^\circ\text{C}$ $T_j = 150^\circ\text{C}$	$t_{d(on)}$	$V_{CE} = 300\text{V}, I_C = 100\text{A},$ $V_{GE} = \pm 15\text{V},$ $R_G = 24\Omega$	-	100	-	ns
Rise time (inductive load) $T_j = 25^\circ\text{C}$ $T_j = 150^\circ\text{C}$	$t_r$		-	60 70	-	
Turn-off delay time (inductive load) $T_j = 25^\circ\text{C}$ $T_j = 150^\circ\text{C}$	$t_{d(off)}$		-	600 700	-	
Fall time $T_j = 25^\circ\text{C}$ $T_j = 150^\circ\text{C}$	$t_f$		-	70 120	-	

Turn-on energy $T_j = 25^\circ\text{C}$ $T_j = 150^\circ\text{C}$	$E_{on}$	$V_{CE}=300\text{V}, I_C=100\text{A},$ $V_{GE}=\pm 15\text{V},$ $R_G=24\Omega, L_S=30\text{nH}$	-	4.85	-	mJ
			-	6.00	-	
Turn-off energy $T_j = 25^\circ\text{C}$ $T_j = 150^\circ\text{C}$	$E_{off}$		-	3.70	-	
			-	4.60	-	

**DIODE Maximum Ratings (D1 to D4)**

Parameter	Symbol	Value	Units
Repetitive peak reverse voltage, $T_j = 25^\circ\text{C}$	$V_{RRM}$	600	V
Diode forward current	$I_F$	75	A
Repetitive peak forward current, $t_p = 1\text{ ms}$	$I_{FRM}$	150	
Thermal resistance, junction to case	$R_{thJC}$	0.95	K/W

**DIODE Electrical Characteristics (D1 to D4)**

Parameter	Symbol	Conditions	Value			Unit
			Min.	Typ.	Max.	
Forward voltage $T_j = 25^\circ\text{C}$ $T_j = 150^\circ\text{C}$	$V_F$	$V_{GE} = 0\text{ V}, I_F = 75\text{A}$	-	1.55 1.45	1.95 -	V
Peak reverse recovery current $T_j = 25^\circ\text{C}$ $T_j = 150^\circ\text{C}$	$I_{RM}$	$I_F = 75\text{A},$ $-di/dt = 1200\text{A}/\mu\text{s}$ $V_R = 300\text{V}, V_{GE} = -15\text{V}$	-	38.0 51.0	-	A
Reverse recovery charge $T_j = 25^\circ\text{C}$ $T_j = 150^\circ\text{C}$	$Q_{rr}$	$I_F = 75\text{A},$ $-di/dt = 1200\text{A}/\mu\text{s}$ $V_R = 300\text{V}, V_{GE} = -15\text{V}$	-	2300 5600	-	nC
Reverse recovery energy $T_j = 25^\circ\text{C}$ $T_j = 150^\circ\text{C}$	$E_{rec}$	$I_F = 75\text{A},$ $-di/dt = 1200\text{A}/\mu\text{s}$ $V_R = 300\text{V}, V_{GE} = -15\text{V}$	-	0.35 1.00	-	mJ

**DIODE Maximum Ratings (D5 and D6)**

Parameter	Symbol	Value	Units
Repetitive peak reverse voltage, $T_j = 25^\circ\text{C}$	$V_{RRM}$	600	V
Diode forward current	$I_F$	100	A
Repetitive peak forward current, $t_p = 1\text{ ms}$	$I_{FRM}$	200	
Thermal resistance, junction to case	$R_{thJC}$	0.80	K/W

**DIODE Electrical Characteristics (D5 and D6)**

Parameter	Symbol	Conditions	Value			Unit
			Min.	Typ.	Max.	
Forward voltage $T_j = 25^\circ\text{C}$ $T_j = 150^\circ\text{C}$	$V_F$	$V_{GE} = 0\text{ V}, I_F = 100\text{A}$	-	1.55 1.45	1.95 -	V
Peak reverse recovery current $T_j = 25^\circ\text{C}$ $T_j = 150^\circ\text{C}$	$I_{RM}$	$I_F = 100\text{A},$ $-di/dt = 1300\text{A}/\mu\text{s}$ $V_R = 300\text{V}, V_{GE} = -15\text{V}$	-	50.0 65.0	-	A
Reverse recovery charge $T_j = 25^\circ\text{C}$ $T_j = 150^\circ\text{C}$	$Q_{rr}$	$I_F = 100\text{A},$ $-di/dt = 1300\text{A}/\mu\text{s},$ $V_R = 300\text{V}, V_{GE} = -15\text{V}$	-	3000 7500	-	nC
Reverse recovery energy $T_j = 25^\circ\text{C}$ $T_j = 150^\circ\text{C}$	$E_{rec}$	$I_F = 100\text{A},$ $-di/dt = 1300\text{A}/\mu\text{s},$ $V_R = 300\text{V}, V_{GE} = -15\text{V}$	-	0.50 1.30	-	mJ

**NTC Thermistor Characteristics**

Parameter	Symbol	Value			Unit
		Min.	Typ.	Max.	
Resistance at 25°C	$R_{25}$	-	33	-	k $\Omega$
Deviation at $R_{100}$	$\Delta R/R$	-	3	-	%
B-value	$B_{25/85}$	-	3980	-	K

**Thermal and Isolation Characteristics**

Parameter	Symbol	Value			Unit
		Min.	Typ.	Max.	
Operating junction temperature	$T_J$	- 40	-	175	°C
Storage temperature range	$T_{STG}$	- 40	-	125	
Operating case temperature	$T_C$	- 40	-	100	
RMS Isolation voltage, terminal to case, 1-3 seconds, 50/ 60 Hz	$V_{iso}$	3000	-	-	V

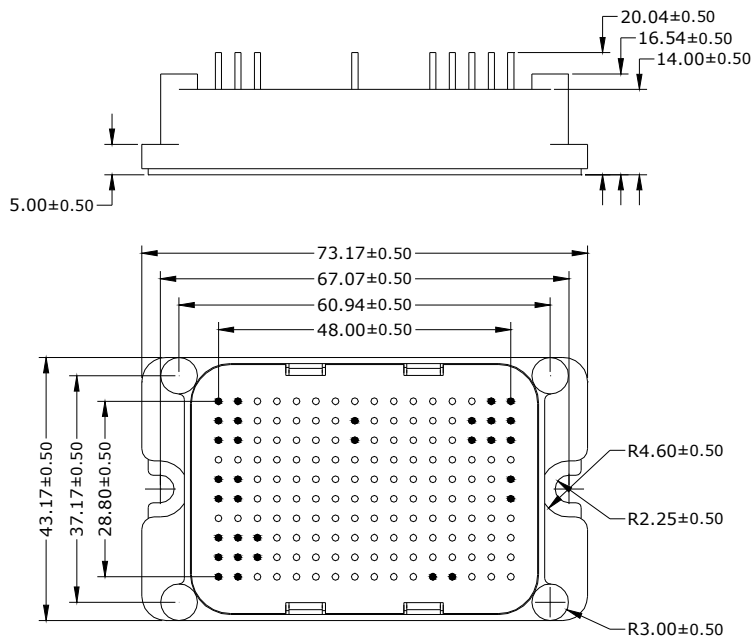
**Package Outline Drawing**

PIN LAYOUT					
PIN	X	Y	PIN	X	Y
1	0	0	18	3.20	22.40
2	0	3.20	19	22.40	25.60
3	0	6.40	20	22.40	22.40
4	3.20	0	21	41.60	25.60
5	3.20	3.20	22	41.60	22.40
6	3.20	6.40	23	44.80	28.80
7	6.40	3.20	24	44.80	25.60
8	6.40	6.40	25	44.80	22.40
9	0	12.80	26	48.00	28.80
10	0	16.00	27	48.00	25.60
11	3.20	12.80	28	48.00	22.40
12	3.20	16.00	29	48.00	16.00
13	0	22.40	30	48.00	12.80
14	0	25.60	31	38.40	0
15	0	28.80	32	35.20	0
16	3.20	28.80			
17	3.20	25.60			

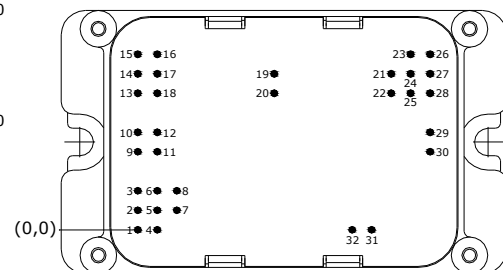

**CAUTION:** These devices are ESD sensitive. Use proper handling procedure.

**Disclaimer**

These specifications may not be considered as a guarantee of components characteristics. Components have to be tested depending on intended application as adjustments may be necessary. The use of **iQXPRZ Power Inc.** components in life support appliances and systems are subject to written approval of **iQXPRZ Power Inc.**