

Features:

- Isolated mounting base 3000V~
- Pressure contact technology with Increased power cycling capability
- Space and weight savings

Typical Applications

- AC/DC Motor drives
- Various rectifiers
- DC supply for PWM inverter

$I_{T(AV)}$ **70A**
 V_{DRM}/V_{RRM} **1900~2500V**
 I_{TSM} **$1.7A \times 10^3$**
 I^2t **$14.5A^2 \cdot S \cdot 10^3$**



SYMBOL	CHARACTERISTIC	TEST CONDITIONS	T _f (°C)	VALUE			UNIT
				Min	Type	Max	
$I_{T(AV)}$	Mean on-state current	180° half sine wave 50Hz Single side cooled, T _c =85°C	125			70	A
$I_{T(RMS)}$	RMS on-state current		125			110	A
V_{DRM} V_{RRM}	Repetitive peak off-state voltage Repetitive peak reverse voltage	$V_{DRM} \& V_{RRM}$ tp=10ms $V_{DSM} \& V_{RSM} = V_{DRM} \& V_{RRM} + 100V$ respectively	125	1900		2500	V
I_{DRM} I_{RRM}	Repetitive peak current	at V_{DRM} at V_{RRM}	125			12	mA
I_{TSM}	Surge on-state current	10ms half sine wave	125			1.70	KA
I^2t	I ² T for fusing coordination	V _R =60%V _{RRM}					14.5
V_{TO}	Threshold voltage		125			0.85	V
r_T	On-state slop resistance						3.50
V_{TM}	Peak on-state voltage	I _{TM} =210A	25			1.93	V
dv/dt	Critical rate of rise of off-state voltage	V _{DM} =67%V _{DRM}	125			800	V/μs
di/dt	Critical rate of rise of on-state current	I _{TM} =140A, Gate source 1.5A t _r ≤0.5μs Repetitive	125			50	A/μs
I_{GT}	Gate trigger current		25	30		100	mA
V_{GT}	Gate trigger voltage	V _A =12V, I _A =1A		0.8		2.5	V
I_H	Holding current			20		150	mA
V_{GD}	Non-trigger gate voltage	V _{DM} =67%V _{DRM}	125	0.2			V
$R_{th(j-c)}$	Thermal resistance Junction to case	Single side cooled				0.39	°C /W
$R_{th(c-h)}$	Thermal resistance case to heat sink	Single side cooled				0.2	°C /W
V_{iso}	Isolation voltage	50Hz, R.M.S, t=1min, I _{iso} :1mA(MAX)		3000			V
F_m	Thermal connection torque (M5)				4.0		N·m
	Mounting torque (M6)				6.0		N·m
T_{stg}	Stored temperature			-40		125	°C
W_t	Weight				115		g
Outline	215F3/223F3						

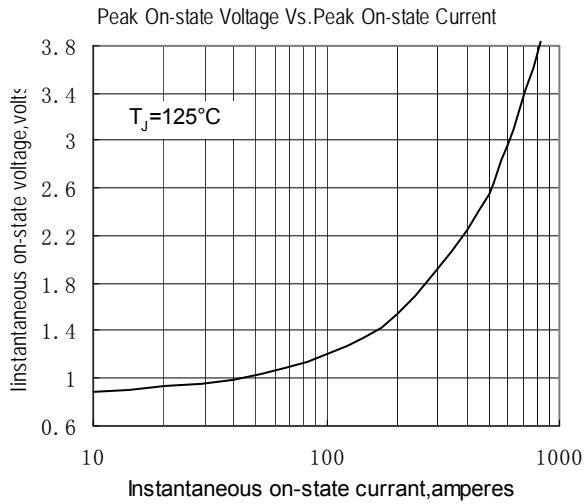

Fig.1

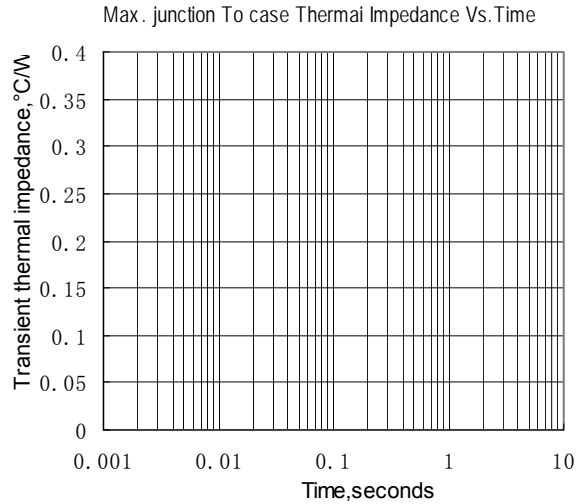

Fig.2

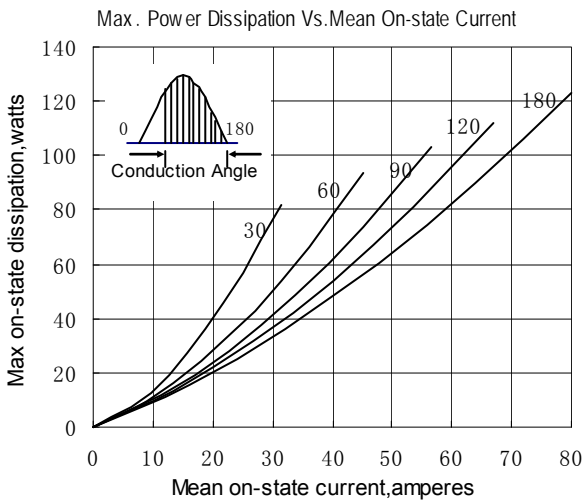

Fig.3

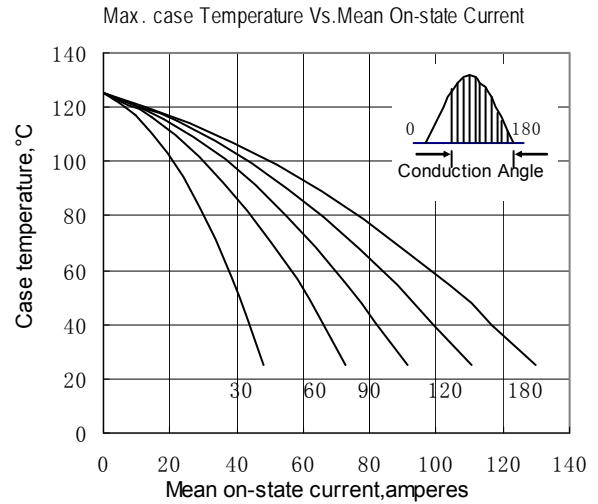

Fig.4

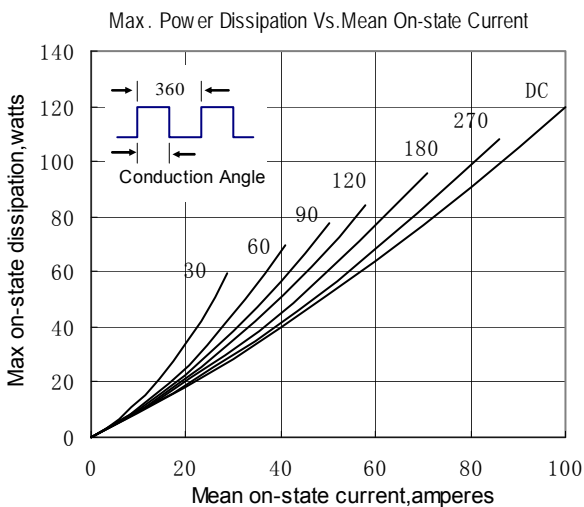

Fig.5

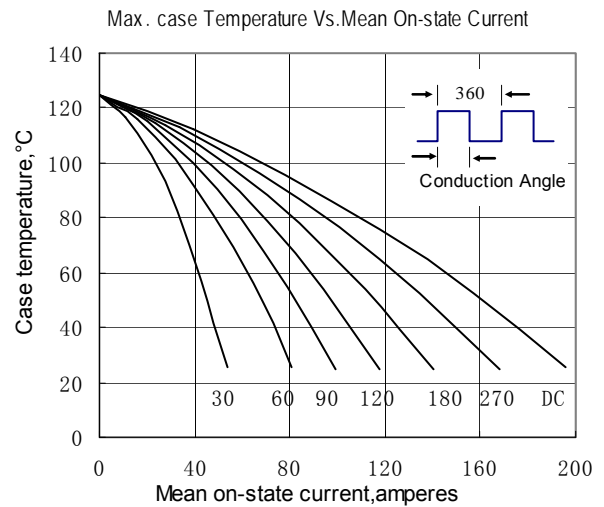

Fig.6

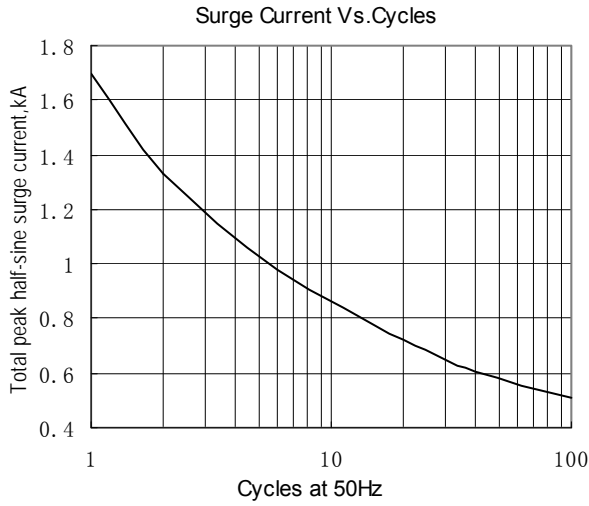

Fig.7

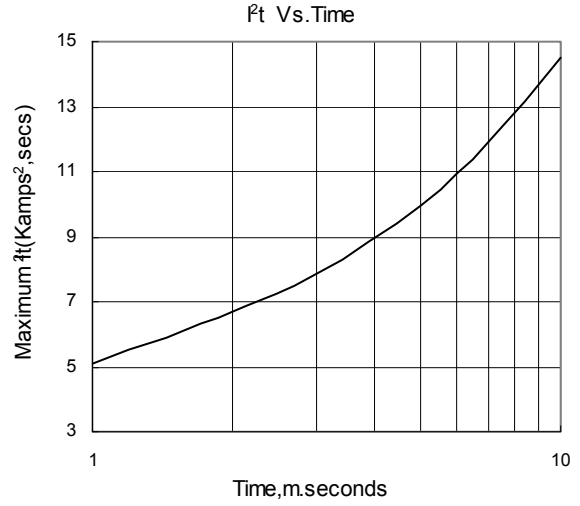

Fig.8

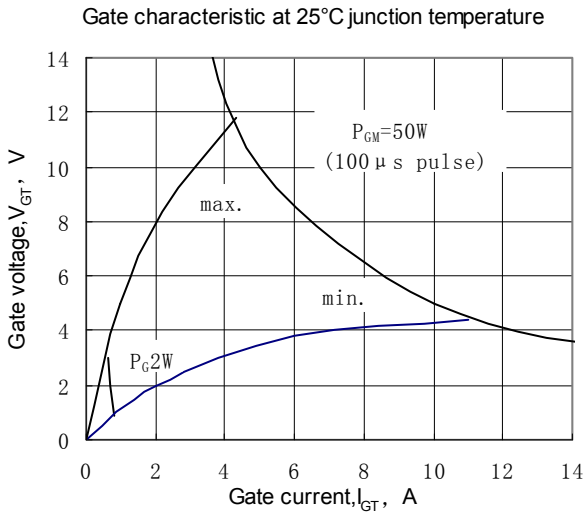

Fig.9

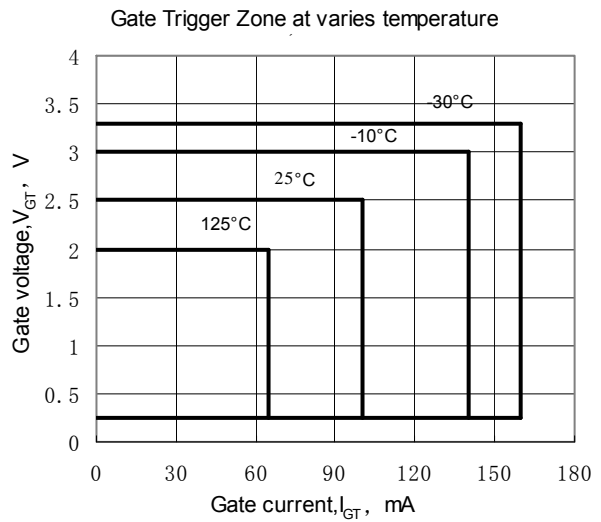
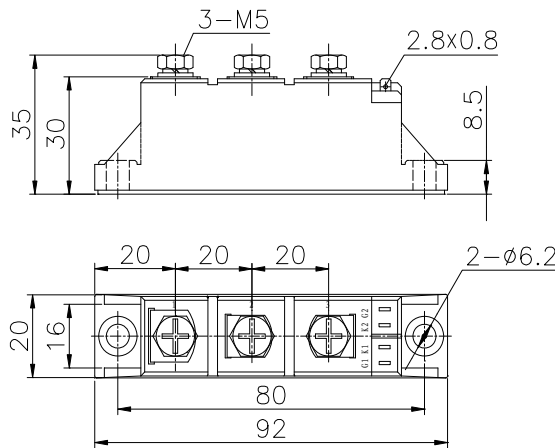

Fig.10

Outline:



215F3

