

Phase Control Thyristors (Capsule Type)

Features

- Metal case with ceramic insulator
- High current rating
- Bifacial cooled
- Center gate trigger



TO-200AB (A-PUK)

Applications

- DC motor controls
- AC controllers
- DC power supplies

Voltage Ratings

Type number	Voltage Code	V_{DRM}/V_{RRM} , Maximum Repetitive peak & off-state voltage V	V_{RSM} , Maximum non-repetitive peak voltage V	I_{DRM}/I_{RRM} , Maximum at $T_J = T_J$ maximum mA
504DCR	04	400	500	20
	06	600	700	
	08	800	900	
	10	1000	1100	
	12	1200	1300	
	14	1400	1500	
	16	1600	1700	

Electrical Ratings ($T_J = 25^\circ\text{C}$, unless otherwise specified)

Parameters	Symbol	Values	Units
Maximum on-state average current 180° sinusoidal conduction @ $T_C = 55^\circ\text{C}$	$I_{T(AV)}$	500	A
Maximum RMS on-state current	$I_{T(RMS)}$	785	A
Maximum peak, one cycle non-repetitive surge current	I_{TSM}	6000	A
Maximum I^2t for fusing @ $t = 10\text{ms}$	I^2t	218	kA^2s
Maximum repetitive peak on and off-state voltage range	V_{RRM}, V_{DRM}	200 to 1600	V
Maximum peak on-state voltage ($T_J = 125^\circ\text{C}$, $I_{peak} = 1100\text{A}$)	V_{TM}	1.3	V
Maximum holding current @ $T_J = 25^\circ\text{C}$	I_H	200	mA
Maximum latching current @ $T_J = 25^\circ\text{C}$	I_L	800	mA
Threshold voltage	V_{TO}	0.81	V
Slope resistance	r_T	0.52	$\text{m}\Omega$

Switching Ratings ($T_J = 25^\circ\text{C}$, unless otherwise specified)

Parameters	Symbol	Values	Units
Rate of rise of turn-on current @ $T_J = T_J$ max, anode voltage $\leq 80\% V_{DRM}$	di/dt	1000	$\text{A}/\mu\text{s}$
Typical turn-on time	t_d	1.0	μs
Typical turn-off time	t_q	100	

Blocking Parameters ($T_J = 25^\circ\text{C}$, unless otherwise specified)			
Parameters	Symbol	Values	Units
Critical rate of rise of off-state voltage @ $T_J = T_J \text{ max}$, linear to 80% rated V_{DRM}	dV/dt	500	$\text{V}/\mu\text{s}$
Maximum peak reverse & off-state leakage current @ $T_J = T_J \text{ max}$, rated $V_{\text{DRM}}/V_{\text{RRM}}$ applied	$I_{\text{RRM}}, I_{\text{DRM}}$	20	mA

Triggering Parameters ($T_J = 25^\circ\text{C}$, unless otherwise specified)			
Parameters	Symbol	Values	Units
DC gate current to trigger	I_{GT}	150	mA
DC gate voltage to trigger	V_{GT}	3.0	V

Thermal and Mechanical Specifications ($T_J = 25^\circ\text{C}$, unless otherwise specified)			
Parameters	Symbol	Values	Units
Maximum operating junction temperature range	T_J	- 40 to +125	$^\circ\text{C}$
Maximum storage temperature range	T_{Stg}	- 40 to +125	$^\circ\text{C}$
Maximum thermal resistance, junction to case	$R_{\text{th}(j-c)}$	0.08	$^\circ\text{C}/\text{W}$
Mounting torque	F	4.2 .. 7.3	kN
Approximate weight	W_T	65	g

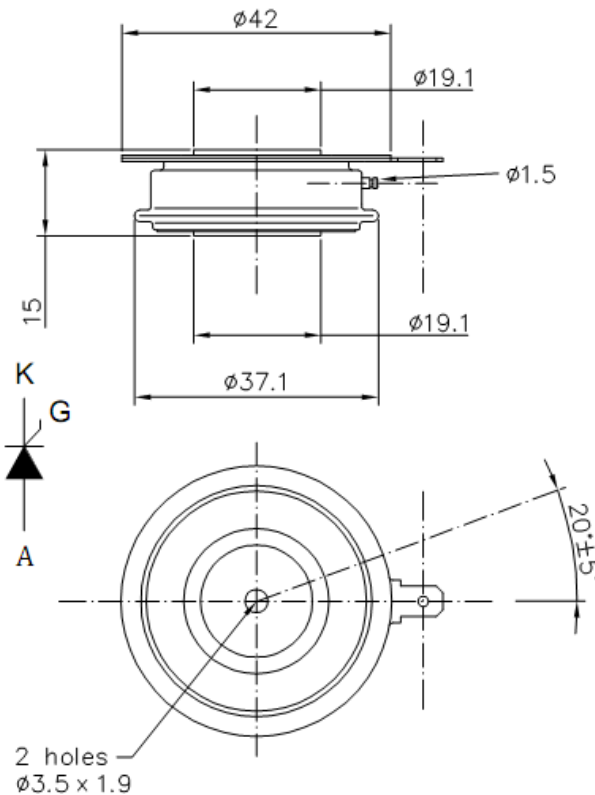

ALL DIMENSIONS IN MM