

## DF15005S-G Thru. DF1510S-G

Reverse Voltage: 50 to 1000V

Forward Current: 1.5A

RoHS Device

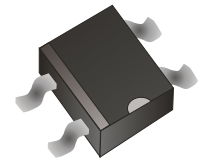

### Features

- Rating to 1000V PRV
- Ideal for printed circuit board
- Low forward voltage drop
- High current capability
- The plastic material has UL flammability classification 94V-0

### Mechanical Data

- Polarit: As marked on Body
- Weight: 0.38 grams
- Mounting position: Any

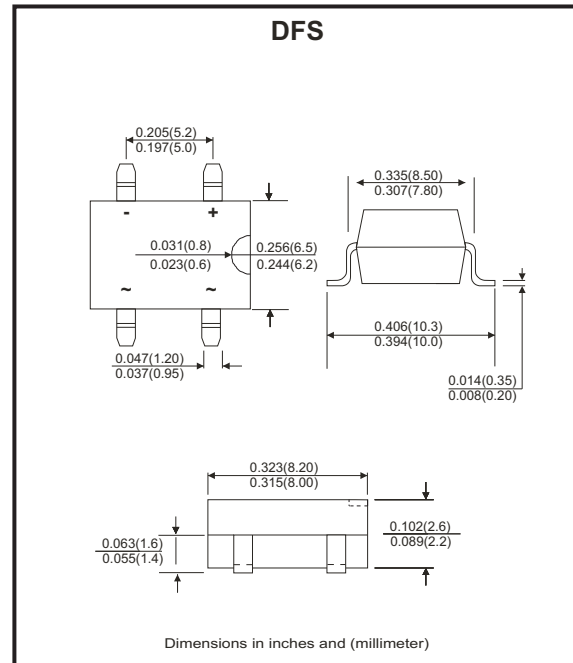

### Maximum ratings and electrical characteristics

Rating at 25°C ambient temperature unless otherwise specified.  
 Single phase, half wave ,60Hz, resistive or inductive load.  
 For capacitive load, derate current by 20%

Parameter	Symbol	DF 15005S-G	DF 1501S-G	DF 1502S-G	DF 1504S-G	DF 1506S-G	DF 1508S-G	DF 1510S-G	Unit
Maximum Recurrent Peak Reverse Voltage	$V_{RRM}$	50	100	200	400	600	800	1000	V
Maximum RMS Voltage	$V_{RMS}$	35	70	140	280	420	560	700	V
Maximum DC Blocking Voltage	$V_{DC}$	50	100	200	400	600	800	1000	V
Maximum Average Forward Rectified Current @ $T_A=40^\circ\text{C}$	$I_{(AV)}$	1.5							A
Peak Forward Surge Current , 8.3ms Single Half Sine-Wave Super Imposed on Rated Load	$I_{FSM}$	50							A
$I^2 t$ Rating for Fusing ( $t < 8.3\text{ms}$ )	$I^2 t$	10.4							$\text{A}^2\text{s}$
Maximum Forward Voltage at 1.5A DC	$V_F$	1.1							V
Maximum DC Reverse Current @ $T_J = 25^\circ\text{C}$ at Rated DC Blocking Voltage @ $T_J = 125^\circ\text{C}$	$I_R$	10 500							$\mu\text{A}$
Typical Junction Capacitance Per Element (Note 1)	$C_J$	25							pF
Typical Thermal Resistance (Note 2)	$R_{\theta JA}$	40							$^\circ\text{C}/\text{W}$
Operating Temperature Range	$T_J$	-55 ~ +150							$^\circ\text{C}$
Storage Temperature Range	$T_{STG}$	-55 ~ +150							$^\circ\text{C}$

Notes:

1. Measured at 1.0MHz and applied reverse voltage of 4.0V DC
2. Unit mounted on P.C.B with 0.50"×0.50" (13×13mm) copper pads.

Company reserves the right to improve product design , functions and reliability without notice.

REV: E

## Rating and Characteristics Curves (DF15005S-G Thru. DF1510S-G)

Fig.1 - Forward Current Derrent Curve

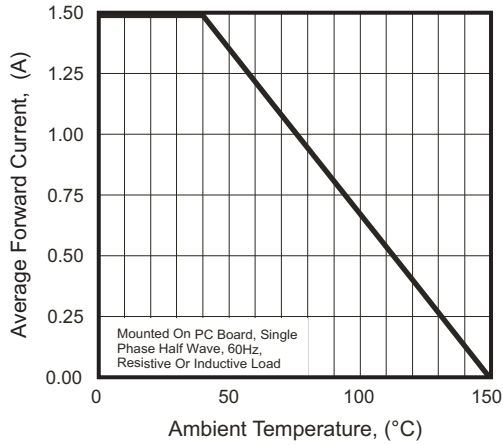

Fig.2 - Maximum Non-Repetitive Peak Forward Surge Current

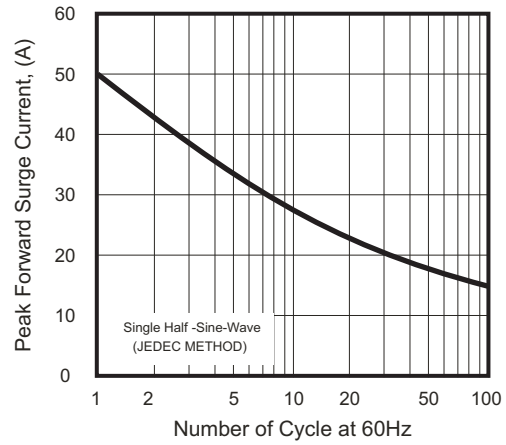

Fig.3 - Typical Junction Capacitance

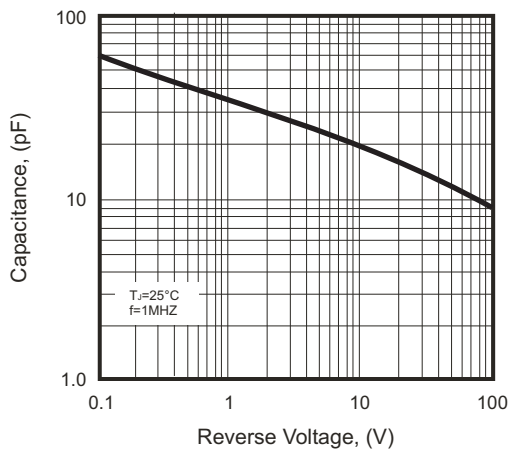

Fig.4 - Typical Forward Characteristics

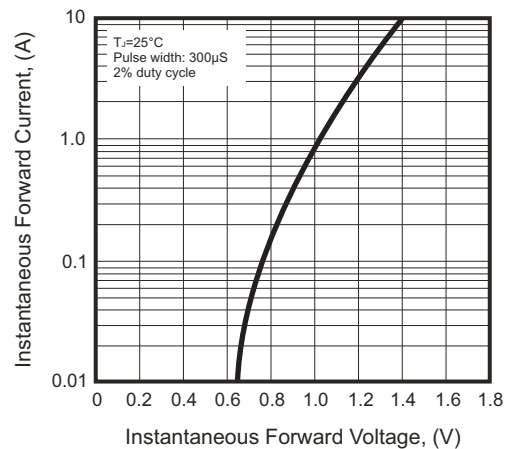
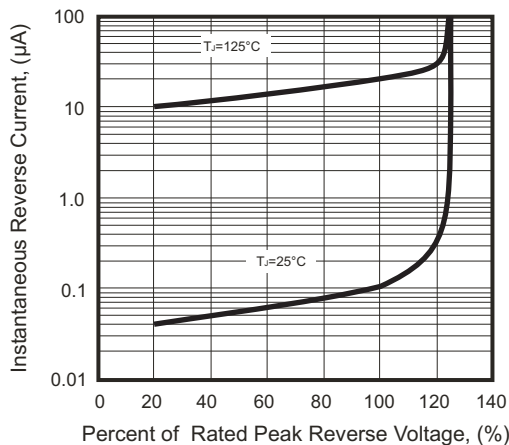

Fig.5 - Typical Reverse Characteristics



Company reserves the right to improve product design , functions and reliability without notice.

REV: E

## Reel Taping Specification

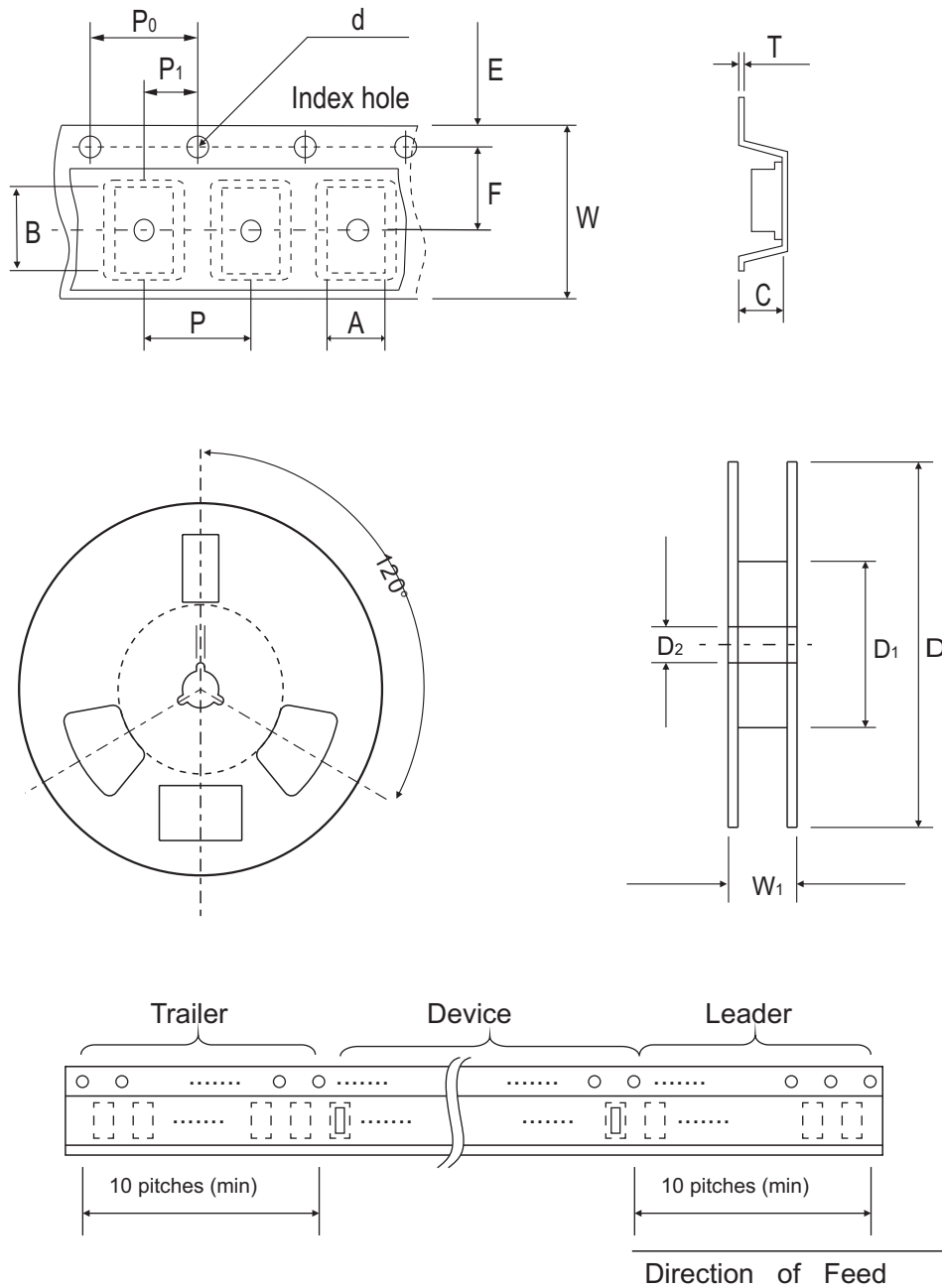

DFS	SYMBOL	A	B	C	d	D	D <sub>1</sub>	D <sub>2</sub>
	(mm)	8.64 ± 0.10	10.41 ± 0.10	3.81 ± 0.10	1.55 ± 0.05	330	50.0 MIN.	13.00 ± 0.20
	(inch)	0.340 ± 0.004	0.409 ± 0.004	0.150 ± 0.004	0.061 ± 0.002	13	1.969 MIN.	0.512 ± 0.008

DFS	SYMBOL	E	F	P	P <sub>0</sub>	P <sub>1</sub>	T	W	W <sub>1</sub>
	(mm)	1.75 ± 0.10	7.50 ± 0.05	12.00 ± 0.10	4.00 ± 0.10	2.00 ± 0.10	0.32	16.00 ± 0.30	16.00~18.40
	(inch)	0.069 ± 0.004	0.295 ± 0.002	0.472 ± 0.004	0.157 ± 0.004	0.079 ± 0.004	0.013	0.630 ± 0.012	0.630~0.724

Company reserves the right to improve product design, functions and reliability without notice.

REV: E  
Page 3

## Marking Code

Part Number	Marking code	Packaging
DF15005SP-G	DF15005S	Tube
DF1501SP-G	DF1501S	Tube
DF1502SP-G	DF1502S	Tube
DF1504SP-G	DF1504S	Tube
DF1506SP-G	DF1506S	Tube
DF1508SP-G	DF1508S	Tube
DF1510SP-G	DF1510S	Tube
DF15005ST-G	DF15005S	Reel
DF1501ST-G	DF1501S	Reel
DF1502ST-G	DF1502S	Reel
DF1504ST-G	DF1504S	Reel
DF1506ST-G	DF1506S	Reel
DF1508ST-G	DF1508S	Reel
DF1510ST-G	DF1510S	Reel

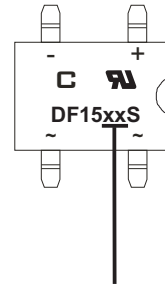

**XX / XXX = Product type marking code**  
**C = Comchip Logo**

Note:

1) Suffix code after part number to specify packaging item .

Packaging	Code
TUBE PACK	P
REEL PACK	T

## Suggested PAD Layout

SIZE	DFS	
	(mm)	(inch)
A	1.20 Min	0.047 Min
B	5.21 REF	0.205 REF
C	1.52 Min	0.060 Min
D	10.26 Max	0.404 Max

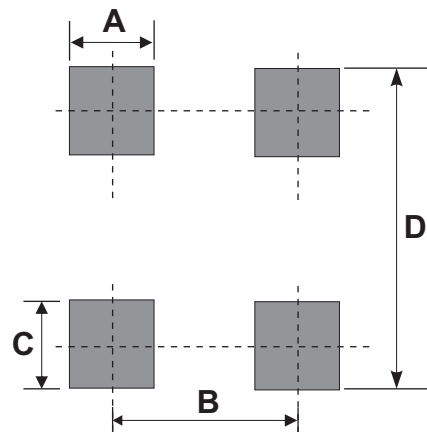

## Standard Packaging

Case Type	TUBE PACK	
	TUBE ( pcs )	Carton ( pcs )
DFS	50	10,000

Case Type	REEL PACK	
	REEL ( pcs )	Reel Size (inch)
DFS	1,000	13

Company reserves the right to improve product design , functions and reliability without notice.

REV: E