

GSM1013

20V P-Channel Enhancement Mode MOSFET

Product Description

GSM1013, P-Channel enhancement mode MOSFET, uses Advanced Trench Technology to provide excellent $R_{DS(ON)}$, low gate charge.

These devices are particularly suited for low voltage power management, such as smart phone and notebook computer, and low in-line power loss are needed in commercial industrial surface mount applications.

Features

- $-20V/-0.6A, R_{DS(ON)}=620m\Omega@V_{GS}=-4.5V$
- $-20V/-0.5A, R_{DS(ON)}=860m\Omega@V_{GS}=-2.5V$
- $-20V/-0.4A, R_{DS(ON)}=1450m\Omega@V_{GS}=-1.8V$
- Low Offset (Error) Voltage
- Low-Voltage Operation
- High-Speed Circuits
- Low Battery Voltage Operation
- SOT-523 package design

Applications

- Drivers: Relays, Solenoids, Lamps, Hammers, Displays, Memories
- Battery Operated Systems
- Power Supply Converter Circuits
- Load/Power Switching Smart Phones, Pagers

Packages & Pin Assignments

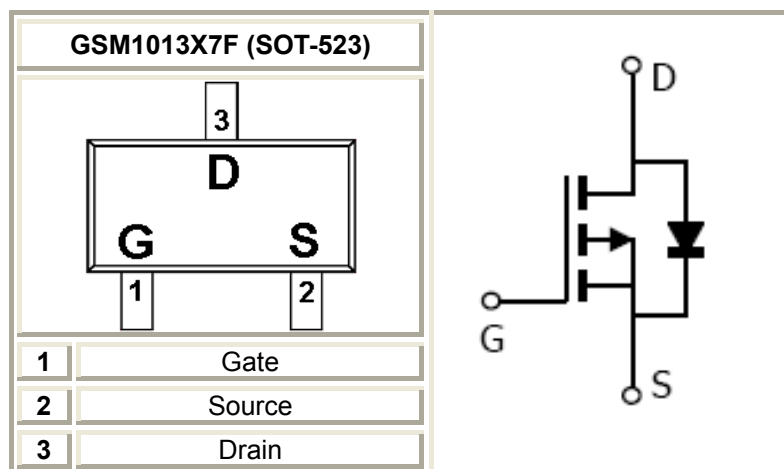

Ordering Information

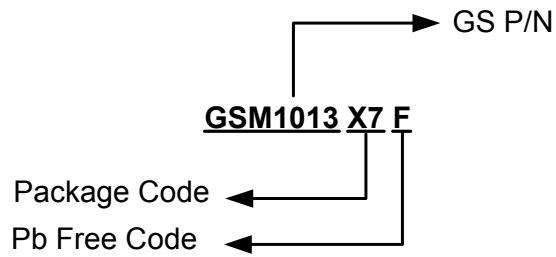

Part Number	Package	Quantity Reel
GSM1013X7F	SOT-523	3000 PCS

Marking Information

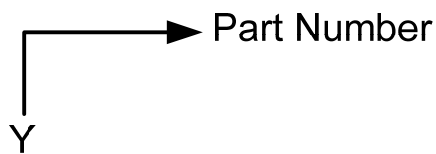

Absolute Maximum Ratings

(T_A=25°C Unless otherwise noted)

Symbol	Parameter	Typical	Unit
V _{DSS}	Drain-Source Voltage	-20	V
V _{GSS}	Gate -Source Voltage	±12	V
I _D	Continuous Drain Current (T _J =150°C)	T _A =25°C	-0.7
		T _A =70°C	-0.4
I _{DM}	Pulsed Drain Current	-1.0	A
I _S	Continuous Source Current (Diode Conduction)	-0.3	A
P _D	Power Dissipation	T _A =25°C	0.27
		T _A =70°C	0.16
T _J	Operating Junction Temperature	-55/150	°C
T _{STG}	Storage Temperature Range	-55/150	°C

Electrical Characteristics

($T_A=25^{\circ}\text{C}$ Unless otherwise noted)

Symbol	Parameter	Conditions	Min	Typ	Max	Unit
Static						
$V_{(BR)DSS}$	Drain-Source Breakdown Voltage	$V_{GS}=0V, I_D=-250\mu A$	-20			V
$V_{GS(th)}$	Gate Threshold Voltage	$V_{DS}=V_{GS}, I_D=-250\mu A$	-0.4		-1.0	
I_{GSS}	Gate Leakage Current	$V_{DS}=0V, V_{GS}=\pm 12V$			± 100	nA
I_{DSS}	Zero Gate Voltage Drain Current	$V_{DS}=-20V, V_{GS}=0V$			-1	uA
		$V_{DS}=-20V, V_{GS}=0V, T_J=85^{\circ}\text{C}$			-5	
$I_{D(on)}$	On-State Drain Current	$V_{DS}\geq 5V, V_{GS}=4.5V$	0.7			A
$R_{DS(on)}$	Drain-Source On-Resistance	$V_{GS}=-4.5V, I_D=-0.6A$		500	620	m Ω
		$V_{GS}=-2.5V, I_D=-0.5A$		700	860	
		$V_{GS}=-1.8V, I_D=-0.4A$		1000	1450	
g_{FS}	Forward Transconductance	$V_{DS}=-10V, I_D=-0.4A$		1		S
V_{SD}	Diode Forward Voltage	$I_S=-0.15A, V_{GS}=0V$		0.65	1.2	V
Dynamic						
C_{iss}	Input Capacitance	$V_{DS}=-10V, V_{GS}=0V, f=1\text{MHz}$		70	100	pF
C_{oss}	Output Capacitance			20		
C_{rss}	Reverse Transfer Capacitance			10		
Q_g	Total Gate Charge	$V_{DS}=-10V, V_{GS}=-4.5V, I_D=-0.25A$		1.0	1.3	nC
Q_{gs}	Gate-Source Charge			0.1		
Q_{gd}	Gate-Drain Charge			0.3		
$t_{d(on)}$	Turn-On Time	$V_{DD}=-10V, R_L=30\Omega, I_D=-0.2A, V_{GEN}=-4.5V, R_G=10\Omega$		10	15	ns
t_r				10	15	
$t_{d(off)}$	Turn-Off Time			40	60	
t_f				30	50	

Typical Performance Characteristics

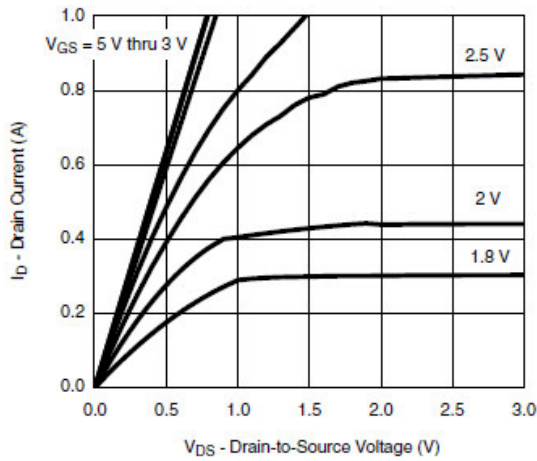

Output Characteristics

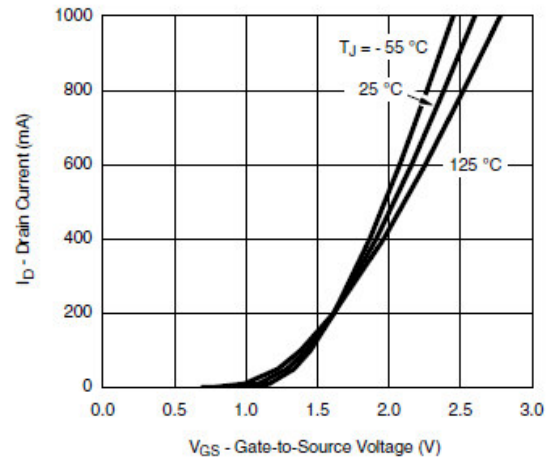

Transfer Characteristics

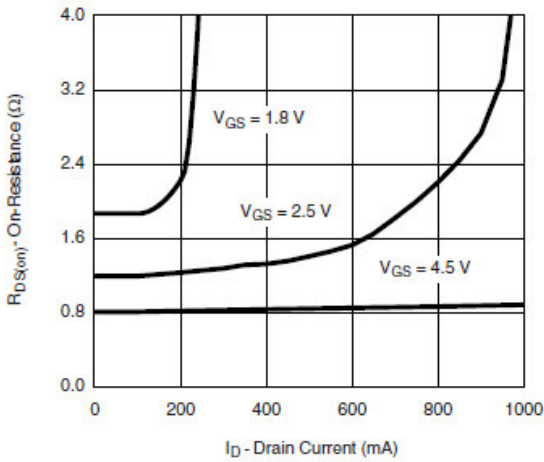

On-Resistance vs. Drain Current

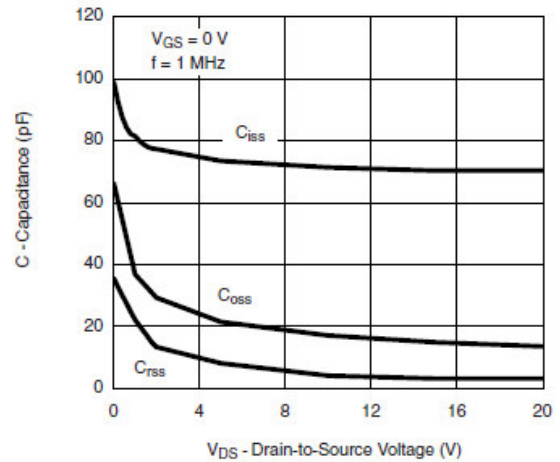

Capacitance

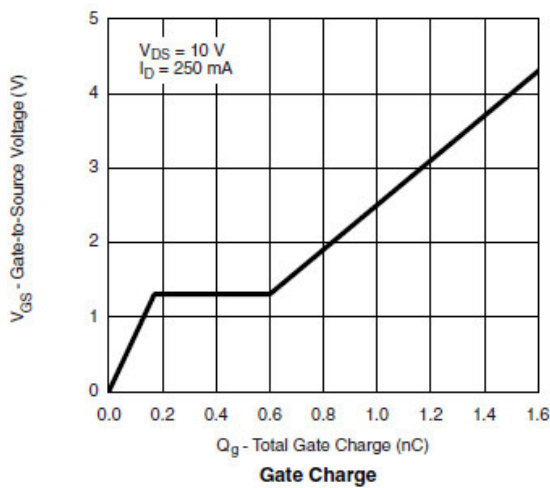

Gate Charge

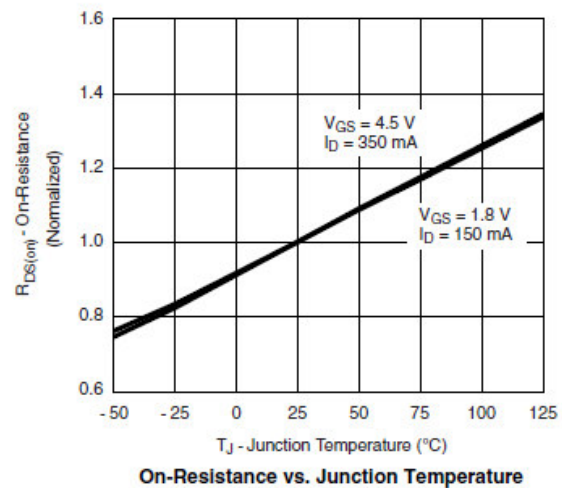

On-Resistance vs. Junction Temperature

Typical Performance Characteristics(Continue)

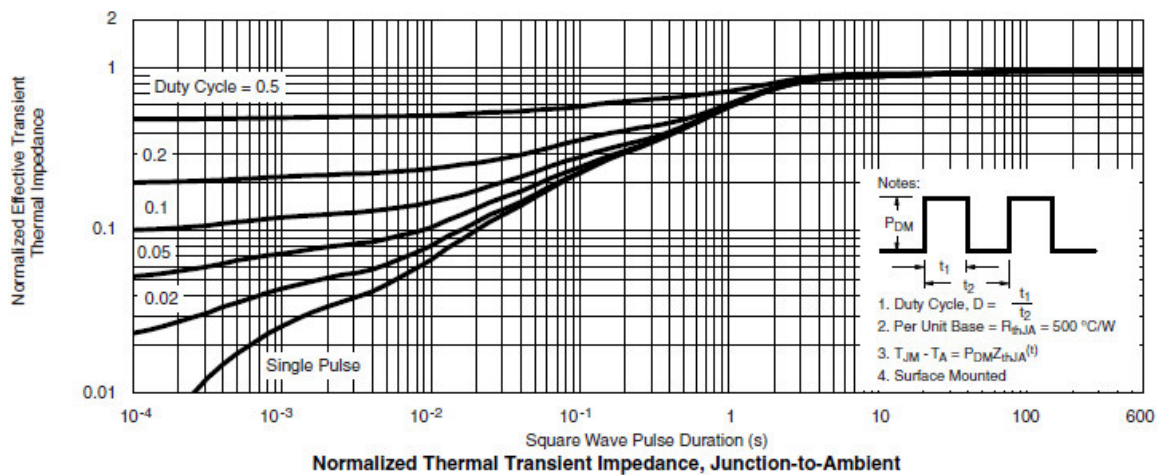
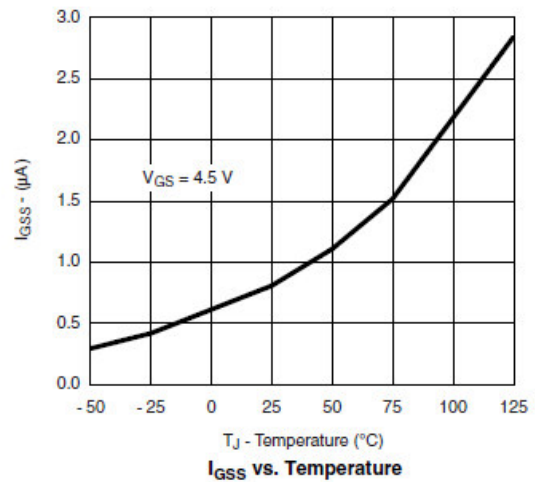
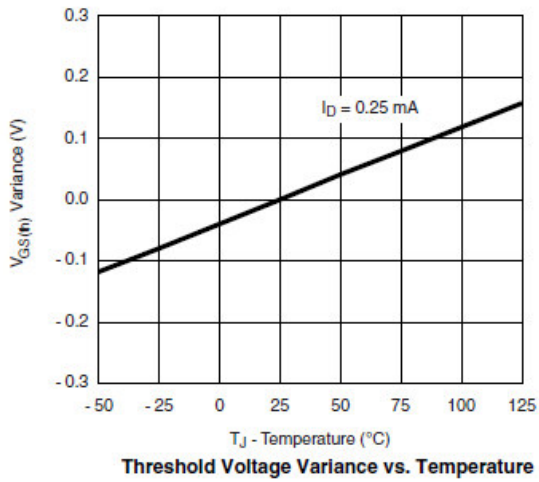
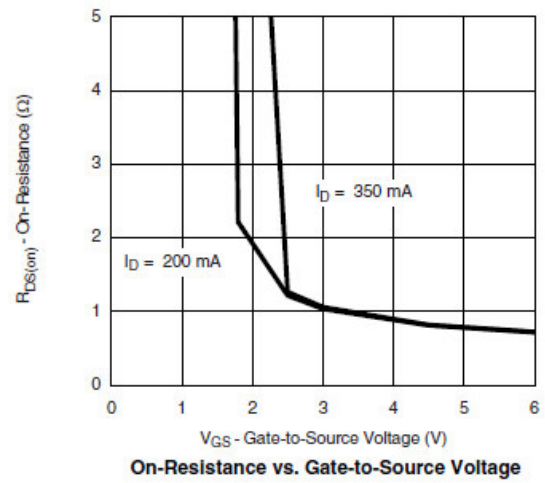
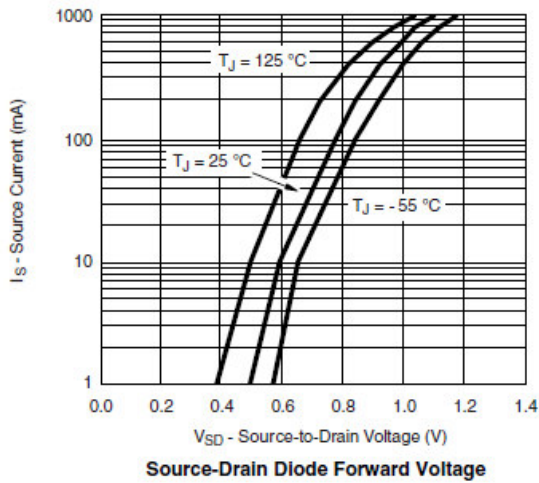

Typical Characteristics

Gate Charge Test Circuit & Waveform

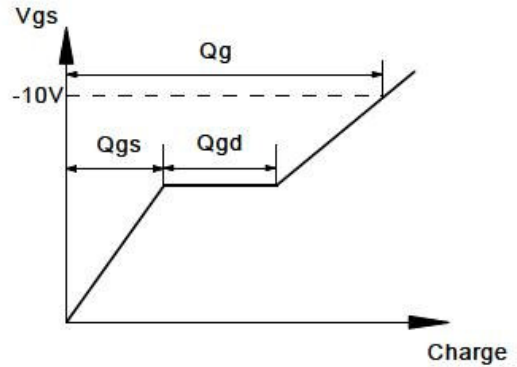
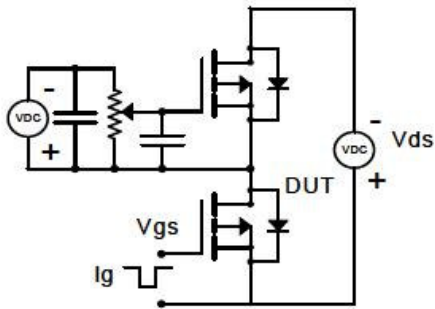

Resistive Switching Test Circuit & Waveforms

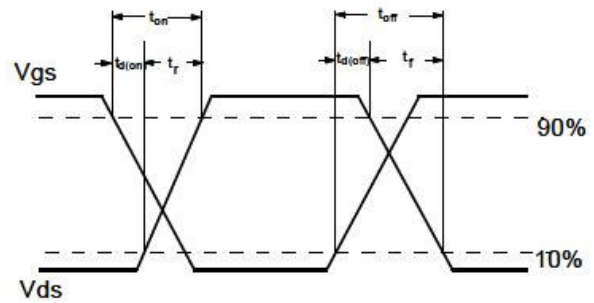
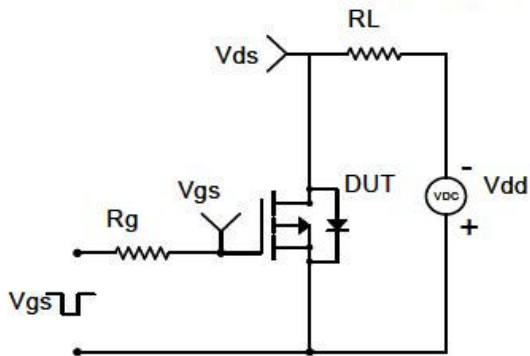

Diode Recovery Test Circuit & Waveforms

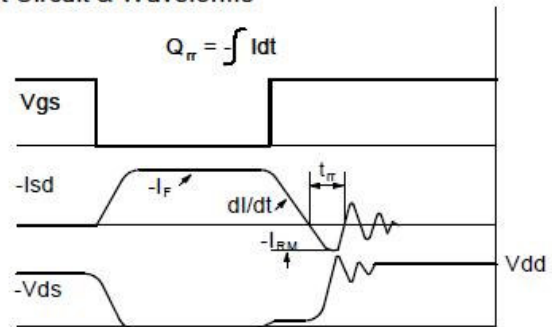
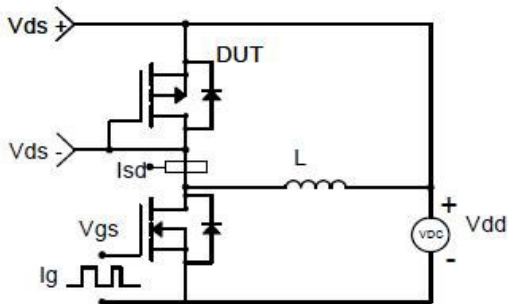

Package Dimension

SOT-523

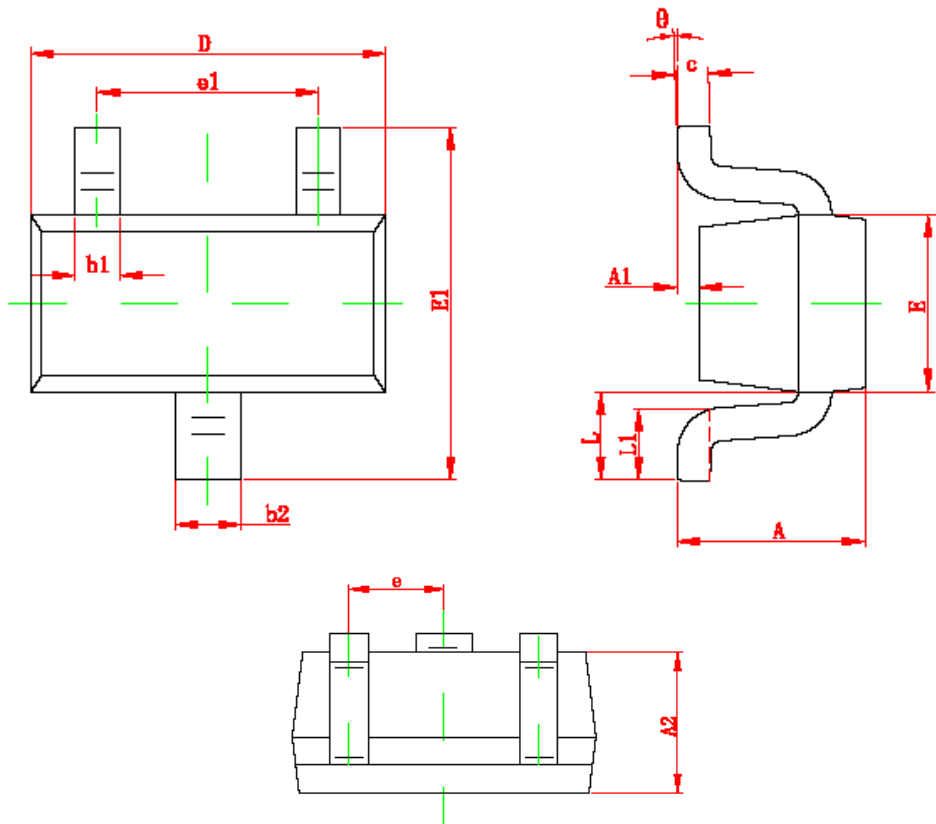





Dimensions





Symbol	Millimeters		Inches	
	Min	Max	Min	Max
A	0.700	0.900	0.028	0.035
A1	0.000	0.100	0.000	0.004
A2	0.700	0.800	0.028	0.031
b1	0.150	0.250	0.006	0.010
b2	0.250	0.325	0.010	0.013
c	0.100	0.200	0.004	0.008
D	1.500	1.700	0.059	0.067
E	0.750	0.850	0.030	0.033
E1	1.450	1.750	0.057	0.069
e	0.500 (TYP)		0.020 (TYP)	
e1	0.900	1.100	0.035	0.043
L	0.550 (REF)		0.022 (REF)	
L1	0.280	0.440	0.011	0.017
θ	0°	4°	0°	4°



NOTICE

Information furnished is believed to be accurate and reliable. However Globaltech Semiconductor assumes no responsibility for the consequences of use of such information nor for any infringement of patents or other rights of third parties, which may result from its use. No license is granted by implication or otherwise under any patent or patent rights of Globaltech Semiconductor. Specifications mentioned in this publication are subject to change without notice. This publication supersedes and replaces all information without express written approval of Globaltech Semiconductor.

CONTACT US

GS Headquarter	
	4F.,No.43-1,Lane11,Sec.6,Minquan E.Rd Neihu District Taipei City 114, Taiwan (R.O.C)
	886-2-2657-9980
	886-2-2657-3630
	sales_twn@gs-power.com

Wu-Xi Branch	
	No.21 Changjiang Rd., WND, Wuxi, Jiangsu, China (INFO. &. TECH. Science Park Building A 210 Room)
	86-510-85217051
	86-510-85211238
	sales_cn@gs-power.com

RD Division	
	824 Bolton Drive Milpitas. CA. 95035
	1-408-457-0587