

GSM3413A

20V P-Channel Enhancement Mode MOSFET

Product Description

GSM3413A, P-Channel enhancement mode MOSFET, uses Advanced Trench Technology to provide excellent $R_{DS(ON)}$, low gate charge.

These devices are particularly suited for low voltage power management, such as smart phone and notebook computer and other battery powered circuits, and low in-line power loss are needed in commercial industrial surface mount applications.

Features

- $-20V/-2.6A, R_{DS(ON)}=110m\Omega@V_{GS}=-4.5V$
- $-20V/-2.2A, R_{DS(ON)}=150m\Omega@V_{GS}=-2.5V$
- $-20V/-1.2A, R_{DS(ON)}=205m\Omega@V_{GS}=-1.8V$
- Super high density cell design for extremely low $R_{DS(ON)}$
- Exceptional on-resistance and maximum DC current capability
- SOT-23 package design

Applications

- Power Management in Note book
- Portable Equipment
- Battery Powered System
- Net Working System

Packages & Pin Assignments

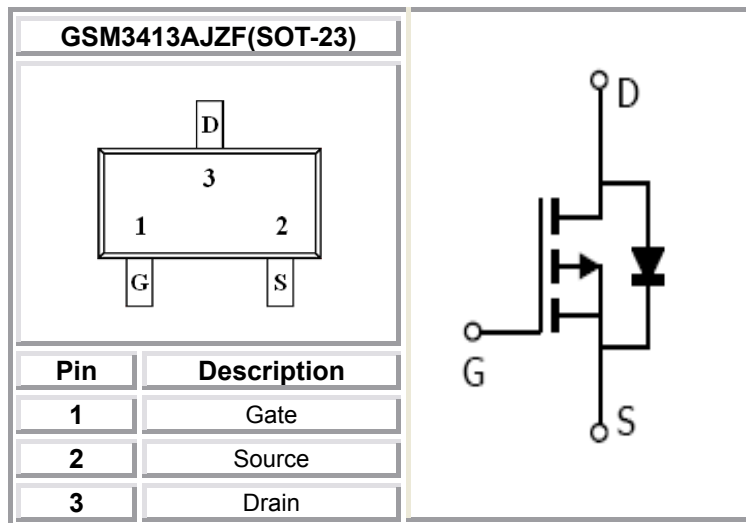

Ordering Information

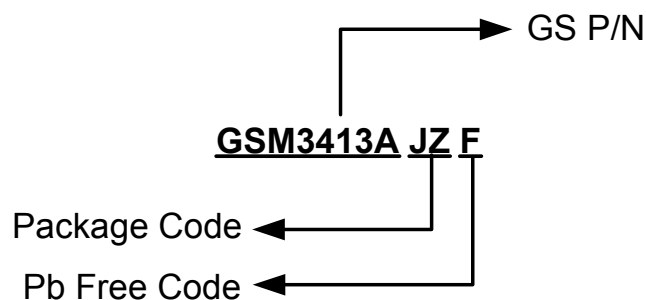

Marking Information

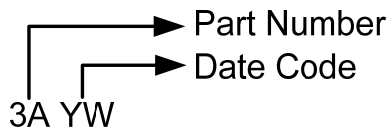

Part Number	Package	Part Marking	Quantity
GSM3413AJZF	SOT-23	3AYW	3000pcs

Absolute Maximum Ratings

T_A=25°C unless otherwise noted

Symbol	Parameter	Typical	Unit
V _{DSS}	Drain-Source Voltage	-20	V
V _{GSS}	Gate -Source Voltage	±12	V
I _D	Continuous Drain Current(T _J =150°C)	T _A =25°C	-2.6
		T _A =70°C	-2.2
I _{DM}	Pulsed Drain Current	-10	A
I _S	Continuous Source Current(Diode Conduction)	-1.6	A
P _D	Power Dissipation	T _A =25°C	1.25
		T _A =70°C	0.8
T _J	Operating Junction Temperature	150	°C
T _{STG}	Storage Temperature Range	-55/150	°C
R _{θJA}	Thermal Resistance-Junction to Ambient	120	°C/ W

Electrical Characteristics

T_A=25°C unless otherwise noted

Symbol	Parameter	Conditions	Min	Typ	Max	Unit
Static						
V _{(BR)DSS}	Drain-Source Breakdown Voltage	V _{GS} =0V, I _D =-250uA	-20			V
V _{GS(th)}	Gate Threshold Voltage	V _{DS} =V _{GS} , I _D =-250uA	-0.3		-0.7	
I _{GSS}	Gate Leakage Current	V _{DS} =0V, V _{GS} =±12V			±100	nA
I _{DSS}	Zero Gate Voltage Drain Current	V _{DS} =-16V, V _{GS} =0V			-1	uA
		V _{DS} =-16V, V _{GS} =0V, T _J =85°C			-30	
I _{D(on)}	On-State Drain Current	V _{DS} ≤-5V, V _{GS} =-4.5V	-6			A
		V _{DS} ≤-5V, V _{GS} =-2.5V	-3			
R _{DS(on)}	Drain-Source On-Resistance	V _{GS} =-4.5V, I _D =-2.6A		105	110	mΩ
		V _{GS} =-2.5V, I _D =-2.2A		140	150	
		V _{GS} =-1.8V, I _D =-1.2A		175	205	
g _{FS}	Forward Transconductance	V _{DS} =-5V, I _D =-2.8A		6.5		S
V _{SD}	Diode Forward Voltage	I _S =-1.25A, V _{GS} =0V		-0.75	-1.3	V
Dynamic						
C _{iss}	Input Capacitance	V _{DS} =-6V, V _{GS} =0V, f=1MHz		415		pF
C _{oss}	Output Capacitance			223		
C _{rss}	Reverse Transfer Capacitance			87		
Q _g	Total Gate Charge	V _{DS} =-6V, V _{GS} =-4.5V, I _D =-2.8A		5.8	10	nC
Q _{gs}	Gate-Source Charge			0.85		
Q _{gd}	Gate-Drain Charge			1.7		
t _{d(on)}	Turn-On Time	V _{DD} =-6V, R _L =6Ω, I _D =-1.0A, V _{GEN} =-4.5V, R _G =6Ω		13	25	ns
T _r				36	60	
t _{d(off)}	Turn-Off Time			42	70	
T _f				34	60	

Typical Performance Characteristics

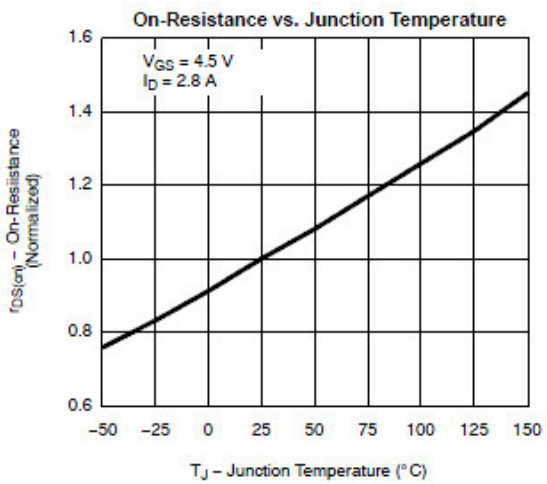
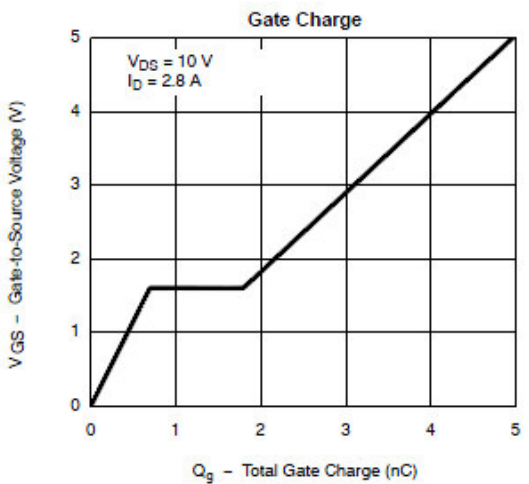
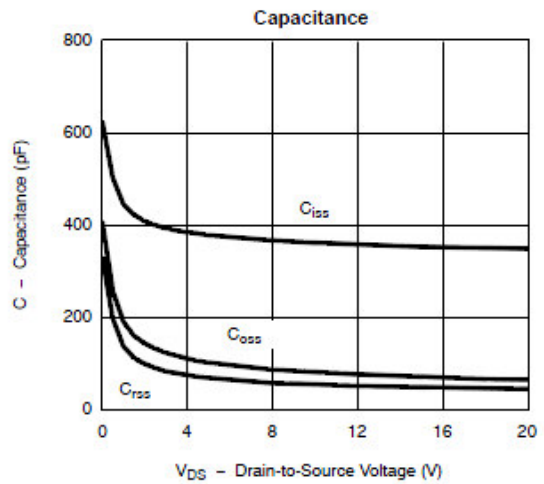
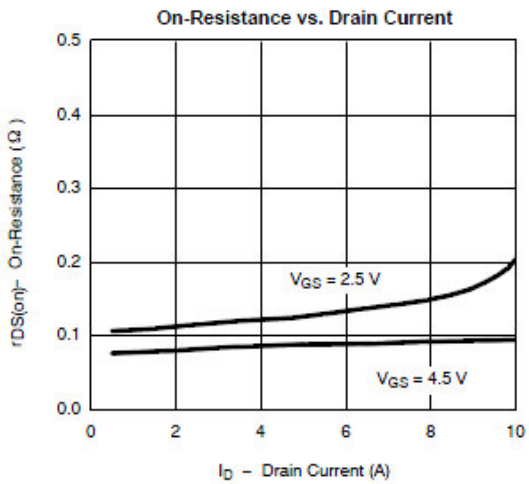
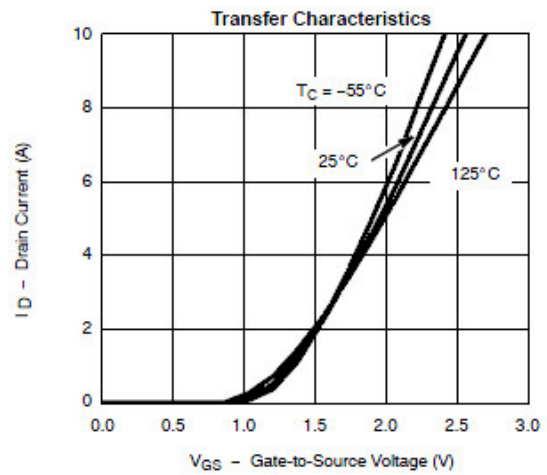
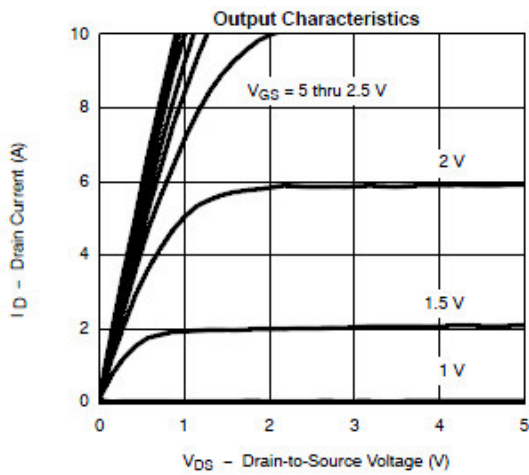

Typical Performance Characteristics (continue)

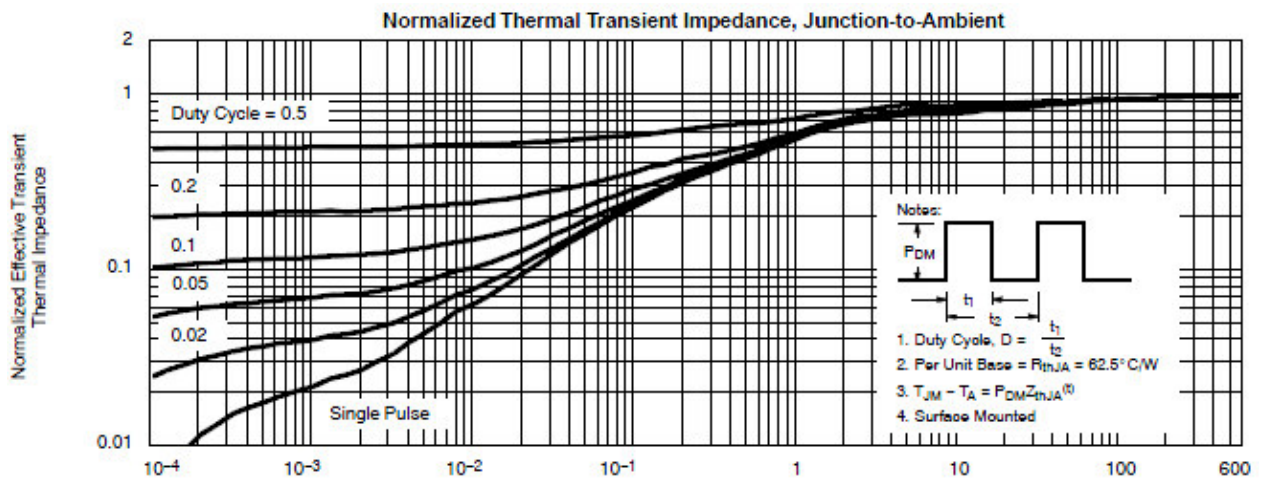
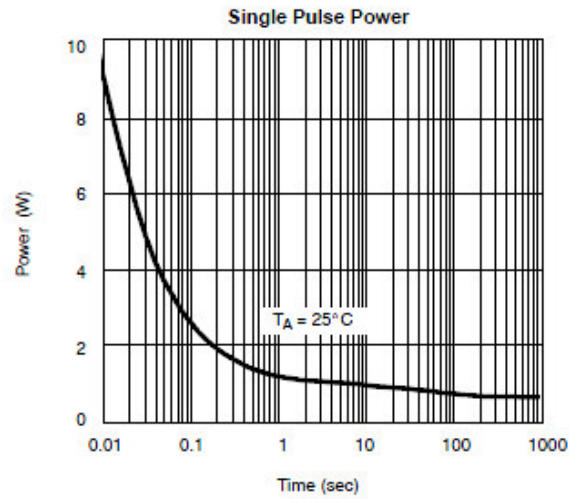
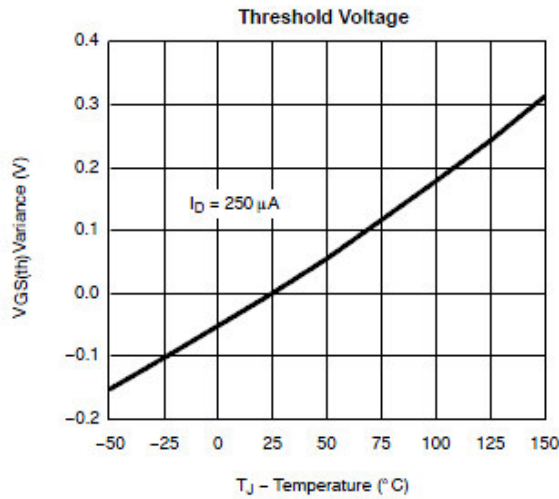
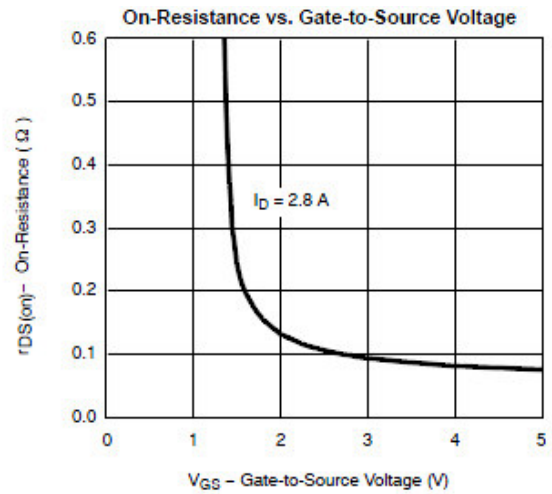
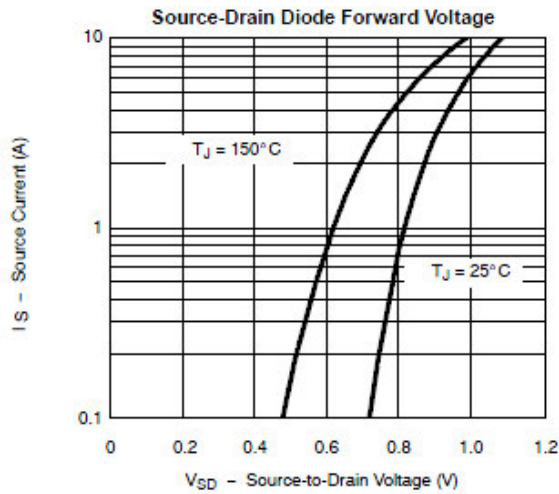

Typical Performance Characteristics (continue)

Gate Charge Test Circuit & Waveform

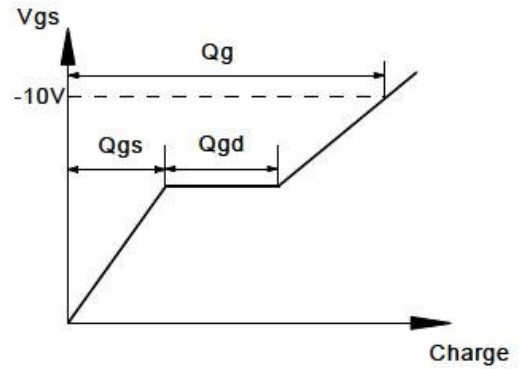
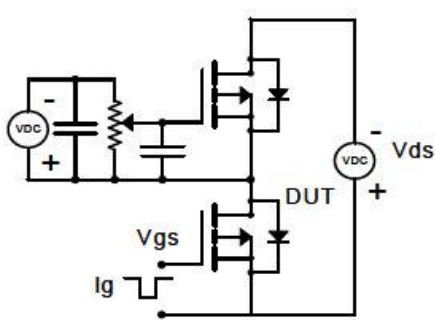

Resistive Switching Test Circuit & Waveforms

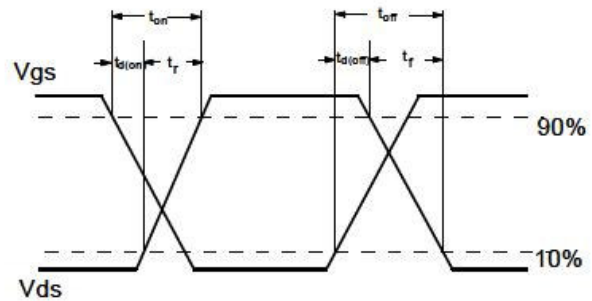
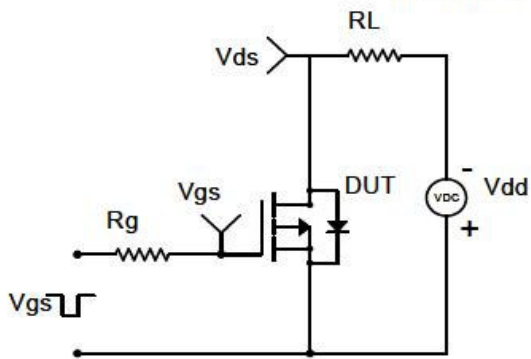

Diode Recovery Test Circuit & Waveforms

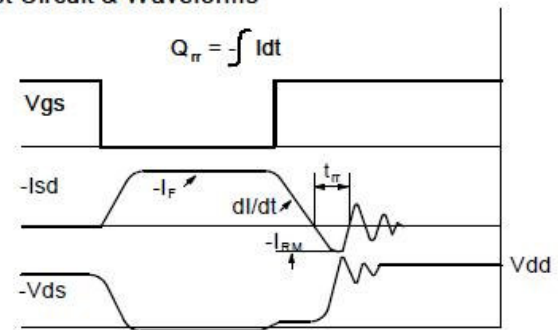
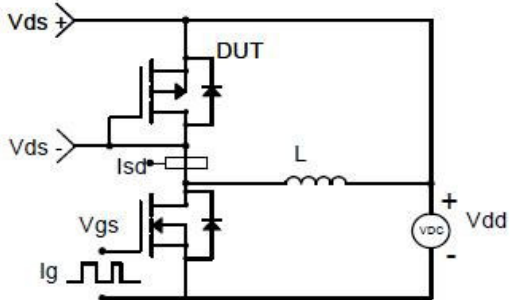

Package Dimension

SOT-23

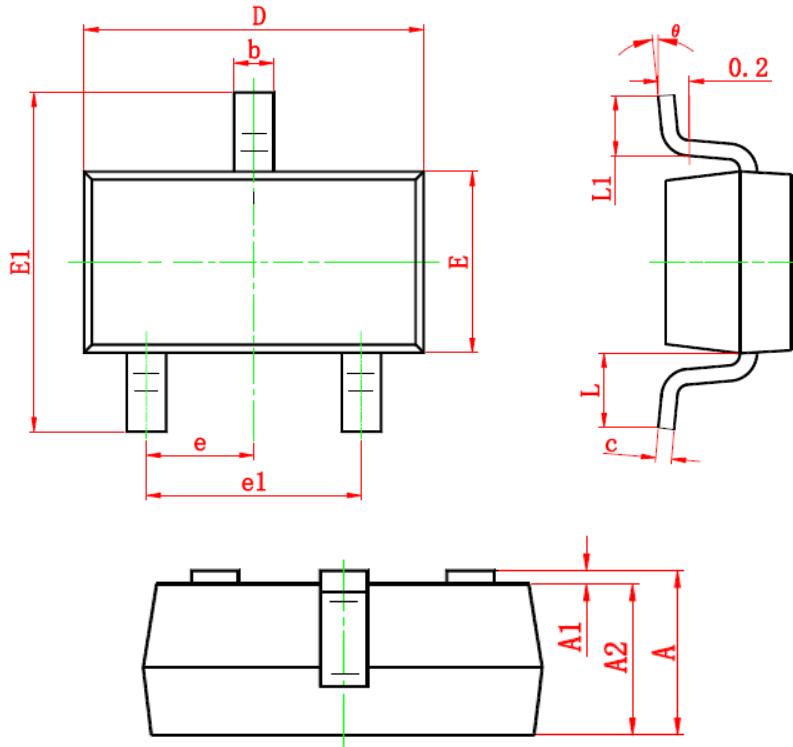









Dimensions				
Symbol	Millimeters		Inches	
	Min	Max	Min	Max
A	0.900	1.200	0.035	0.043
A1	0.000	0.100	0.000	0.004
A2	0.900	1.100	0.035	0.039
b	0.300	0.500	0.012	0.020
c	0.080	0.150	0.003	0.006
D	2.800	3.000	0.110	0.118
E	1.200	1.400	0.047	0.055
E1	2.250	2.550	0.089	0.100
e	0.950 TYP		0.037 TYP	
e1	1.800	2.000	0.071	0.079
L	0.550 REF		0.022 REF	
L1	0.300	0.500	0.012	0.020
θ	0°	8°	0°	6°



NOTICE

Information furnished is believed to be accurate and reliable. However Globaltech Semiconductor assumes no responsibility for the consequences of use of such information nor for any infringement of patents or other rights of third parties, which may result from its use. No license is granted by implication or otherwise under any patent or patent rights of Globaltech Semiconductor. Specifications mentioned in this publication are subject to change without notice. This publication supersedes and replaces all information without express written approval of Globaltech Semiconductor.

CONTACT US

GS Headquarter	
	4F.,No.43-1,Lane11,Sec.6,Minquan E.Rd Neihu District Taipei City 114, Taiwan (R.O.C)
	886-2-2657-9980
	886-2-2657-3630
	sales_twn@gs-power.com

Wu-Xi Branch	
	No.21 Changjiang Rd., WND, Wuxi, Jiangsu, China (INFO. &. TECH. Science Park Building A 210 Room)
	86-510-85217051
	86-510-85211238
	sales_cn@gs-power.com

RD Division	
	824 Bolton Drive Milpitas. CA. 95035
	1-408-457-0587