

# GSM3310W

## 30V N-Channel Enhancement Mode MOSFET

### Product Description

GSM3310W, N-Channel enhancement mode MOSFET, uses Advanced Trench Technology to provide excellent  $R_{DS(ON)}$ , low gate charge.

These devices are particularly suited for low voltage power management, such as smart phone and notebook computer and other battery powered circuits, and low in-line power loss are needed in commercial industrial surface mount applications.

### Features

- 30V/16A,  $R_{DS(ON)}=17m\Omega@V_{GS}=10V$
- 30V/10A,  $R_{DS(ON)}=19m\Omega@V_{GS}=4.5V$
- Super high density cell design for extremely low  $R_{DS(ON)}$
- DFN3X3-8L package design

### Applications

- DC/DC Converter
- Load Switch
- Power Management in Notebook Computer

### Packages & Pin Assignments

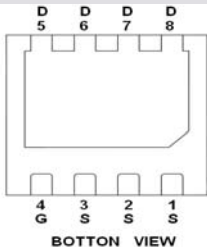
GSM3310WFF (DFN3X3-8L)		
 <p style="text-align: center;">BOTTON VIEW</p>		
Pin	Symbol	Description
1	S	Source
2	S	Source
3	S	Source
4	G	Gate
5	D	Drain
6	D	Drain
7	D	Drain
8	D	Drain

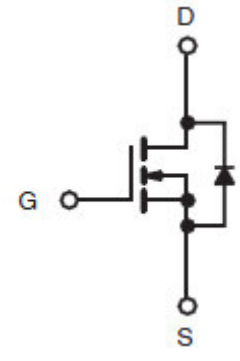

## Ordering Information

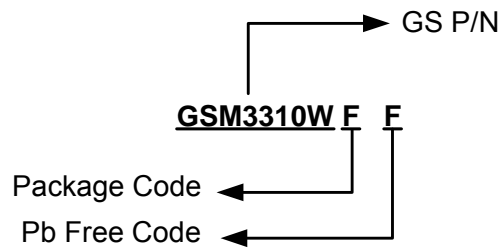

Part Number	Package	Quantity Reel
GSM3310WFF	DFN3X3-8L	5000 PCS

## Marking Information

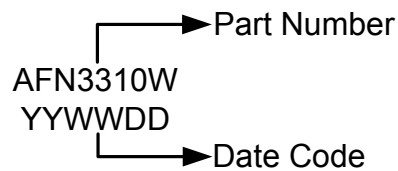

Part Number "AFN3310W"="GSM3310W"

## Absolute Maximum Ratings

$T_A=25^{\circ}\text{C}$  Unless otherwise noted

Symbol	Parameter	Typical	Unit
$V_{DSS}$	Drain-Source Voltage	30	V
$V_{GSS}$	Gate-Source Voltage	$\pm 20$	V
$I_D$	Continuous Drain Current ( $T_J=150^{\circ}\text{C}$ )	$T_A=25^{\circ}\text{C}$	16
		$T_A=70^{\circ}\text{C}$	10
$I_{DM}$	Pulsed Drain Current	40	A
$I_S$	Continuous Source Current (Diode Conduction)	1.6	A
$P_D$	Power Dissipation	$T_A=25^{\circ}\text{C}$	36
		$T_A=70^{\circ}\text{C}$	18
$P_{DSM}$	Power Dissipation	$T_A=25^{\circ}\text{C}$	3
		$T_A=70^{\circ}\text{C}$	2
$T_J$	Operating Junction Temperature	150	$^{\circ}\text{C}$
$T_{STG}$	Storage Temperature Range	-55/150	$^{\circ}\text{C}$
$R_{\theta JA}$	Thermal Resistance-Junction to Ambient	120	$^{\circ}\text{C}/\text{W}$

## Electrical Characteristics

T<sub>A</sub>=25°C Unless otherwise noted

Symbol	Parameter	Conditions	Min	Typ	Max	Unit
<b>Static</b>						
V <sub>(BR)DSS</sub>	Drain-Source Breakdown Voltage	V <sub>GS</sub> =0V, I <sub>D</sub> =250uA	30			V
V <sub>GS(th)</sub>	Gate Threshold Voltage	V <sub>DS</sub> =V <sub>GS</sub> , I <sub>D</sub> =250uA	0.7		1.8	
I <sub>GSS</sub>	Gate Leakage Current	V <sub>DS</sub> =0V, V <sub>GS</sub> =±20V			±100	nA
I <sub>DSS</sub>	Zero Gate Voltage Drain Current	V <sub>DS</sub> =30V, V <sub>GS</sub> =0V			1	uA
		V <sub>DS</sub> =30V, V <sub>GS</sub> =0V T <sub>J</sub> =85°C			10	
I <sub>D(ON)</sub>	On-State Drain Current	V <sub>DS</sub> ≥ 5V, V <sub>GS</sub> =10V	40			A
R <sub>DS(on)</sub>	Drain-Source On-Resistance	V <sub>GS</sub> =10V, I <sub>D</sub> =16A		12	17	mΩ
		V <sub>GS</sub> =4.5V, I <sub>D</sub> =10A		14	19	
g <sub>FS</sub>	Forward Transconductance	V <sub>DS</sub> =15V, I <sub>D</sub> =10A		24		S
V <sub>SD</sub>	Diode Forward Voltage	I <sub>S</sub> =3.0A, V <sub>GS</sub> =0V		0.8	1.3	V
<b>Dynamic</b>						
Q <sub>g</sub>	Total Gate Charge	V <sub>DS</sub> =15V, V <sub>GS</sub> =4.5V, I <sub>D</sub> =10A		8	12	nC
Q <sub>gs</sub>	Gate-Source Charge			2.0		
Q <sub>gd</sub>	Gate-Drain Charge			2.3		
C <sub>iss</sub>	Input Capacitance	V <sub>DS</sub> =15V, V <sub>GS</sub> =0V, f=1MHz		800		pF
C <sub>oss</sub>	Output Capacitance			180		
C <sub>rss</sub>	Reverse Transfer Capacitance			70		
t <sub>d(on)</sub>	Turn-On Time	V <sub>DD</sub> =15V, R <sub>L</sub> =1.5Ω, I <sub>D</sub> =10A, V <sub>GEN</sub> =10V, R <sub>G</sub> =1Ω		8	15	ns
t <sub>r</sub>				8	15	
t <sub>d(off)</sub>	Turn-Off Time			16	28	
t <sub>f</sub>				8	16	

## Typical Performance Characteristics

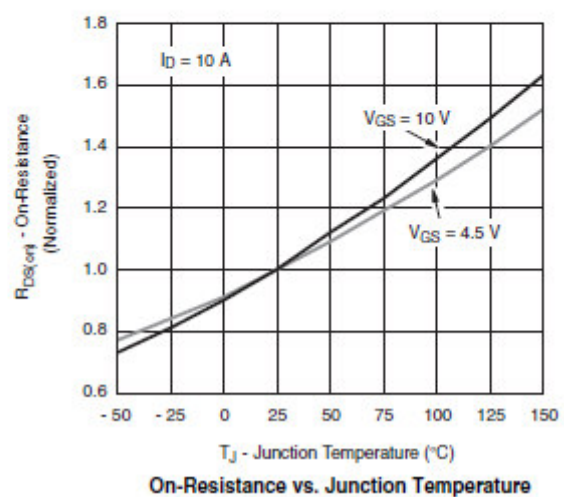
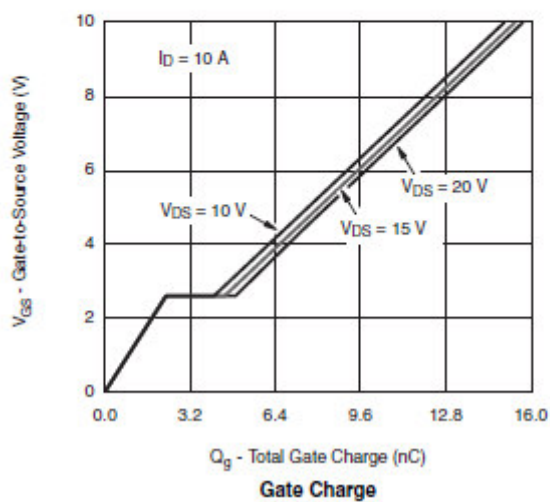
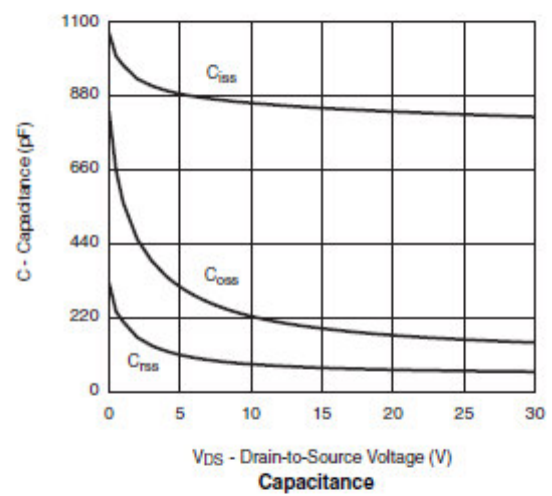
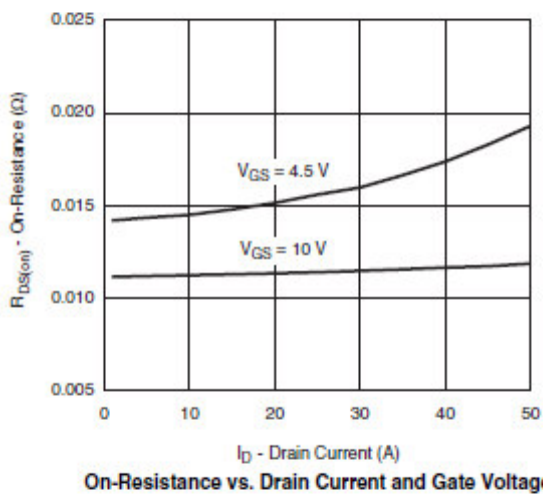
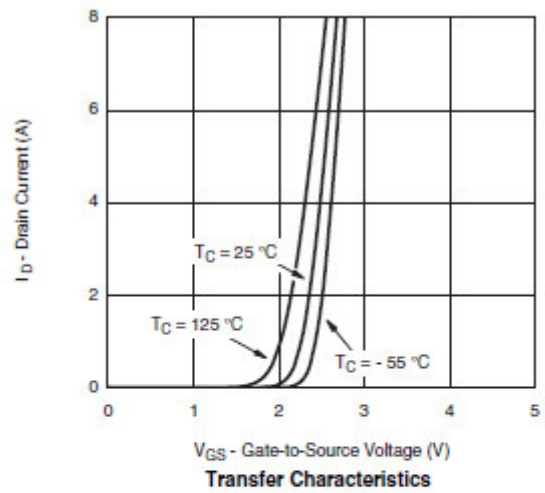
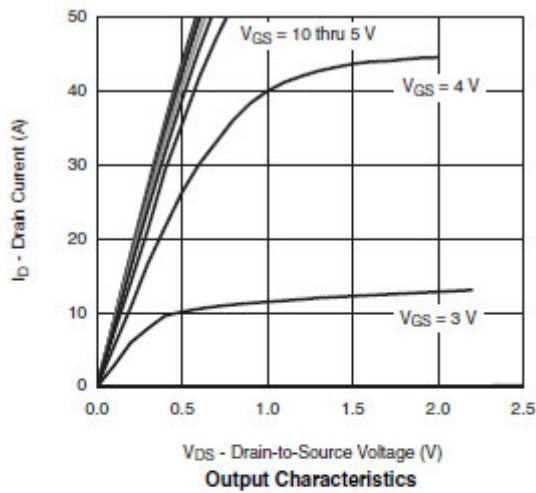

## Typical Performance Characteristics (Continue)

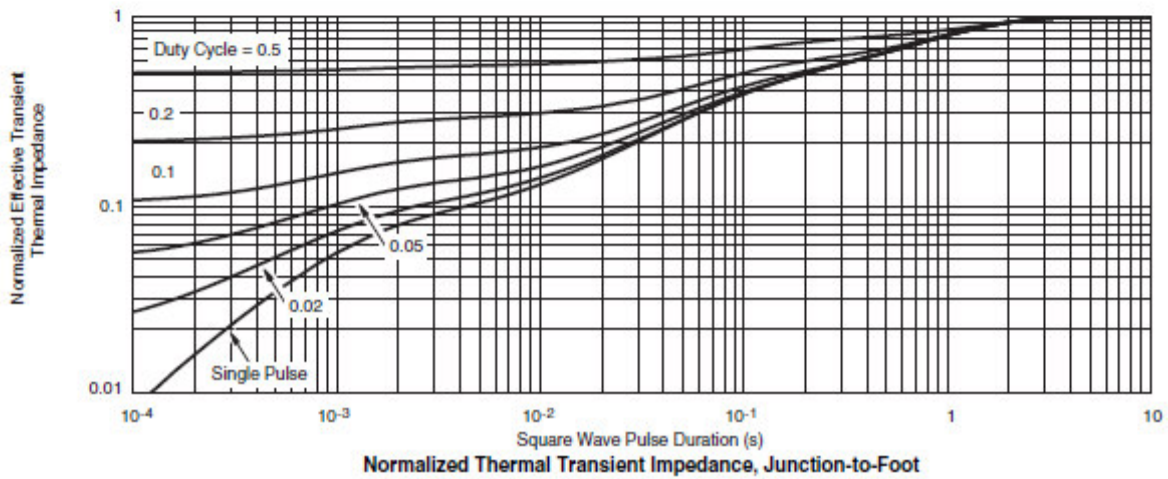
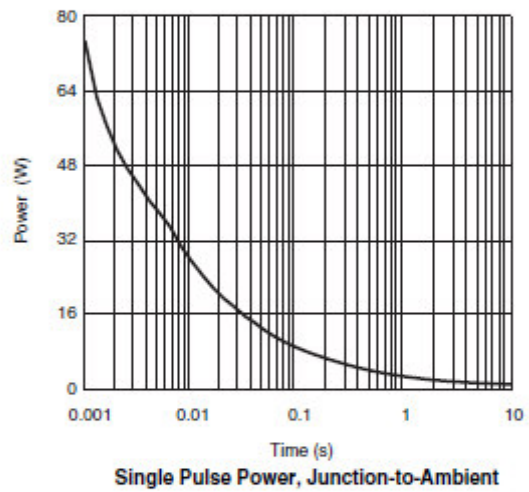
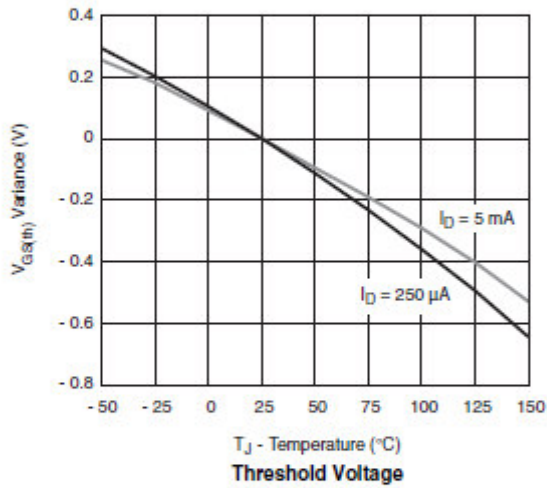
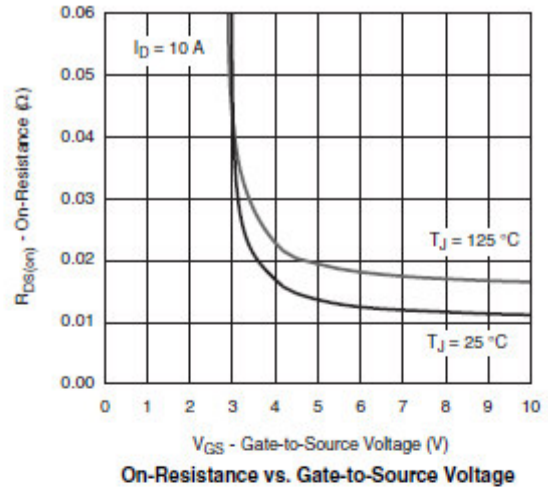
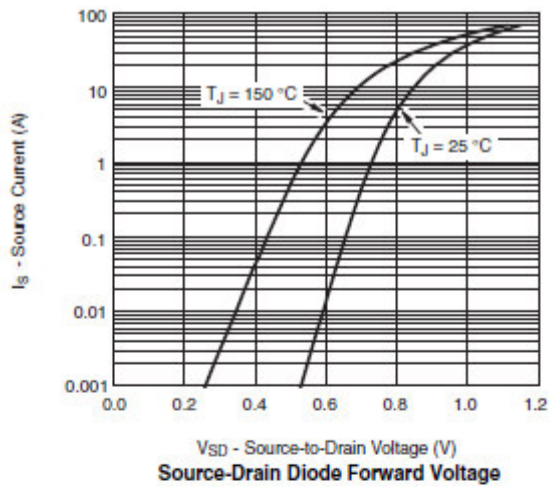

## Typical Performance Characteristics (Continue)

### Gate Charge Test Circuit & Waveform

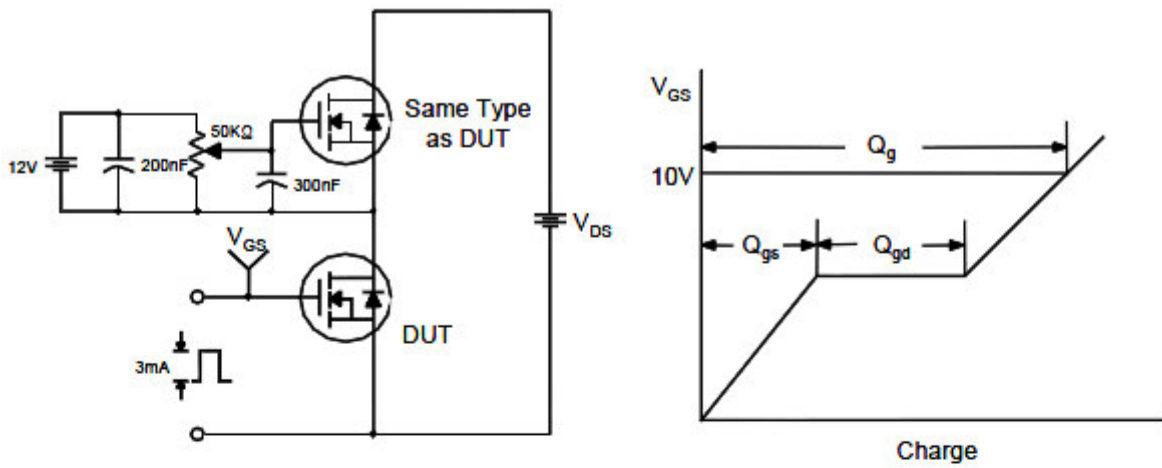

### Resistive Switching Test Circuit & Waveforms

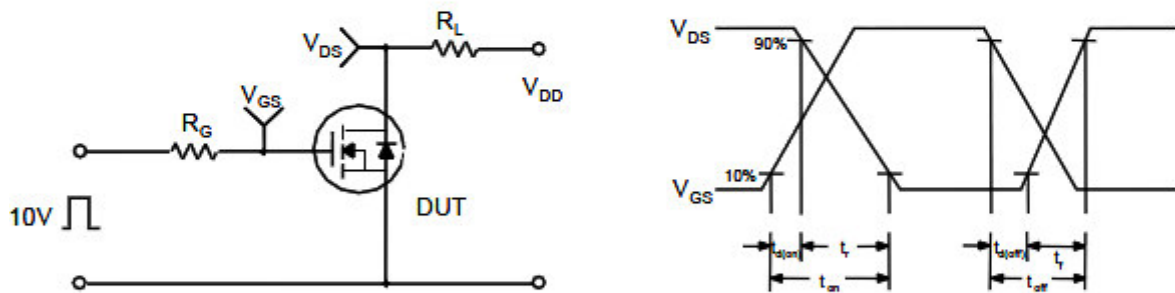

### Unclamped Inductive Switching Test Circuit & Waveforms

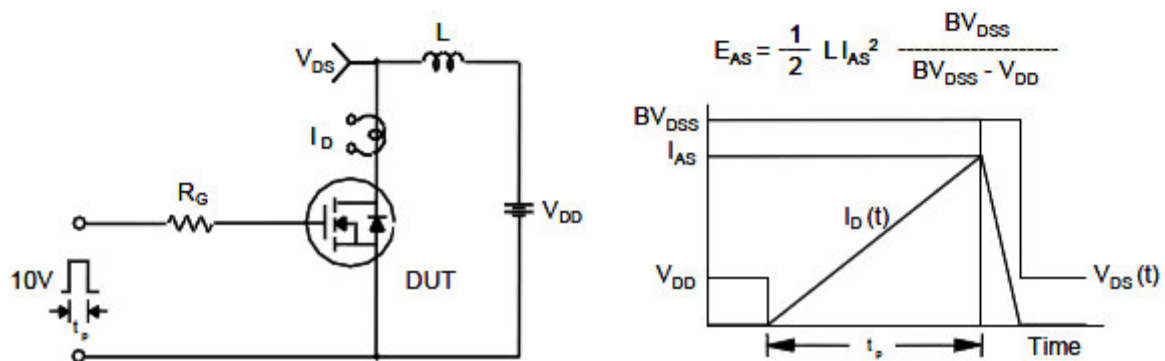

## Package Dimension

### DFN3x3-8L

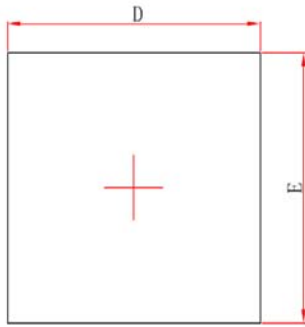

Top View

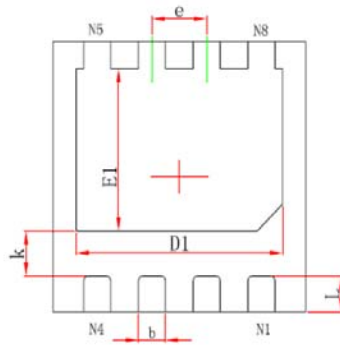

Bottom View

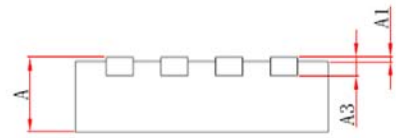





Side View

Dimensions				
SYMBOL	Millimeters		Inches	
	MIN	MAX	MIN	MAX
A	0.800	0.900	0.031	0.035
A1	0.000	0.05	0.000	0.002
A3	0.203REF		0.008REF	
D	2.924	3.076	0.115	0.121
E	2.924	3.076	0.115	0.121
D1	2.350	2.550	0.093	0.100
E1	1.700	1.90	0.067	0.075
k	0.450	0.550	0.018	0.022
b	0.270	0.370	0.011	0.015
e	0.650TYP		0.026TYP	
L	0.324	0.476	0.013	0.019



## NOTICE

Information furnished is believed to be accurate and reliable. However Globaltech Semiconductor assumes no responsibility for the consequences of use of such information nor for any infringement of patents or other rights of third parties, which may result from its use. No license is granted by implication or otherwise under any patent or patent rights of Globaltech Semiconductor. Specifications mentioned in this publication are subject to change without notice. This publication supersedes and replaces all information without express written approval of Globaltech Semiconductor.

## CONTACT US

GS Headquarter	
	4F.,No.43-1,Lane11,Sec.6,Minquan E.Rd NeiHu District Taipei City 114, Taiwan (R.O.C)
	886-2-2657-9980
	886-2-2657-3630
	sales_twn@gs-power.com

Wu-Xi Branch	
	No.21 Changjiang Rd., WND, Wuxi, Jiangsu, China (INFO. & TECH. Science Park Building A 210 Room)
	86-510-85217051
	86-510-85211238
	sales_cn@gs-power.com

RD Division	
	824 Bolton Drive Milpitas. CA. 95035
	1-408-457-0587