

GSM1304E

20V N-Channel Enhancement Mode MOSFET

Product Description

GSM1304E, N-Channel enhancement mode MOSFET, uses Advanced Trench Technology to provide excellent $R_{DS(ON)}$, low gate charge.

These devices are particularly suited for low voltage power management, such as smart phone and notebook computer and other battery powered circuits, and low in-line power loss are needed in commercial industrial surface mount applications.

Features

- 20V/1.8A , $R_{DS(ON)}= 320m\Omega@V_{GS}=4.5V$
- 20V/1.5A , $R_{DS(ON)}= 450m\Omega@V_{GS}=2.5V$
- 20V/1.2A , $R_{DS(ON)}= 580m\Omega@V_{GS}=1.8V$
- Super high density cell design for extremely low $R_{DS(ON)}$
- Exceptional on-resistance and maximum DC current capability
- ESD Protected
- SOT-323(SC-70) package design

Applications

- Net Working System
- Drivers: Relays, Solenoids, Lamps, Hammers, Displays, Memories
- Battery Operated Systems
- Power Supply Converter Circuits
- Load/Power Switching Smart Phones, Pagers

Packages & Pin Assignments

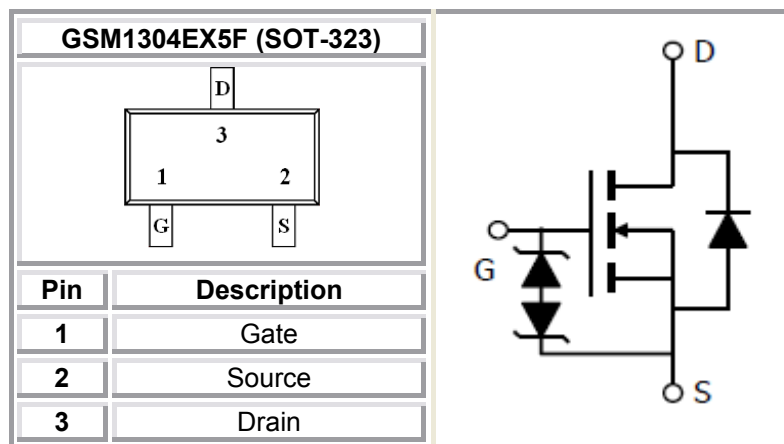

Ordering Information

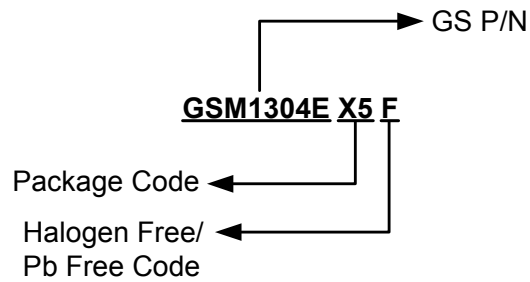

Part Number	Package	Quantity
GSM1304EX5F	SOT-323	3000 PCS

Marking Information

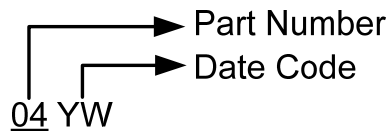

Absolute Maximum Ratings

T_A=25°C Unless otherwise noted

Symbol	Parameter	Typical	Unit
V _{DSS}	Drain-Source Voltage	20	V
V _{GSS}	Gate-Source Voltage	±12	V
I _D	Continuous Drain Current(T _J =150°C)	T _A =25°C	1.8
		T _A =70°C	1.2
I _{DM}	Pulsed Drain Current	6	A
I _S	Continuous Source Current(Diode Conduction)	1	A
P _D	Power Dissipation	T _A =25°C	0.35
		T _A =70°C	0.22
T _J	Operating Junction Temperature	150	°C
T _{STG}	Storage Temperature Range	-55/150	°C
R _{θJA}	Thermal Resistance-Junction to Ambient	120	°C/ W

Electrical Characteristics

T_A=25°C unless otherwise noted

Symbol	Parameter	Conditions	Min	Typ	Max	Unit
Static						
V _{(BR)DSS}	Drain-Source Breakdown Voltage	V _{GS} =0V, I _D =250μA	20			V
V _{GS(th)}	Gate Threshold Voltage	V _{DS} =V _{GS} , I _D =250μA	0.3		0.8	V
I _{GSS}	Gate Leakage Current	V _{DS} =0V, V _{GS} =±12V			±1	mA
I _{DSS}	Zero Gate Voltage Drain Current	V _{DS} = 16V, V _{GS} =0V			1	μA
		V _{DS} = 16V, V _{GS} =0V, T _J =85°C			5	
I _{D(on)}	On-State Drain Current	V _{DS} ≥ 5V, V _{GS} =4.5V	1.8			A
R _{DS(on)}	Drain-Source On-Resistance	V _{GS} =4.5V, I _D =1.8A		290	320	mΩ
		V _{GS} =2.5V, I _D =1.5A		400	450	
		V _{GS} =1.8V, I _D =1.2A		500	580	
g _{fs}	Forward Transconductance	V _{DS} =10V, I _D =1.0A		1		S
V _{SD}	Diode Forward Voltage	I _S =1.0A, V _{GS} =0V		0.65	1.2	V
Dynamic						
C _{iss}	Input Capacitance	V _{DS} =10V, V _{GS} =0V, f=1MHz		70		pF
C _{oss}	Output Capacitance			20		
C _{rss}	Reverse Transfer Capacitance			8		
Q _g	Total Gate Charge	V _{DS} =10V, V _{GS} =4.5V, I _D =1.2A		1.06	1.38	nC
Q _{gs}	Gate-Source Charge			0.18		
Q _{gd}	Gate-Drain Charge			0.32		
t _{d(on)}	Turn-On Time	V _{DD} =10V, R _L =20Ω, I _D =1.2A, V _{GEN} =4.5V, R _G =1Ω		18	26	ns
t _r				20	28	
t _{d(off)}	Turn-Off Time			70	110	
t _f				25	40	

Typical Performance Characteristics

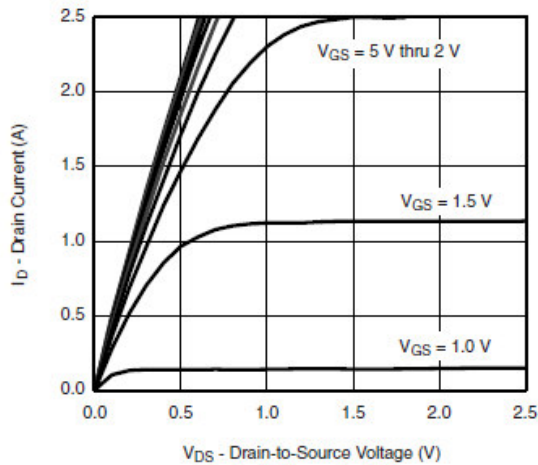

Output Characteristics

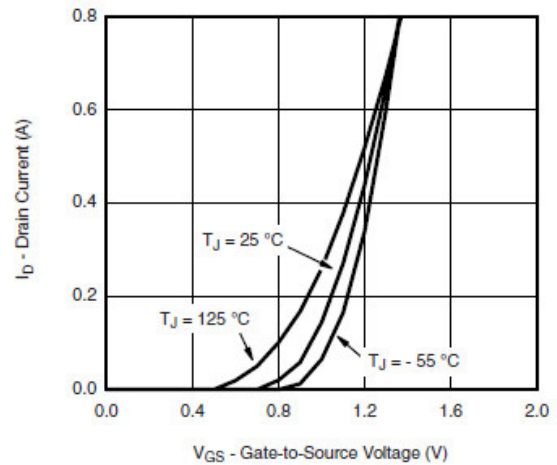

Transfer Characteristics

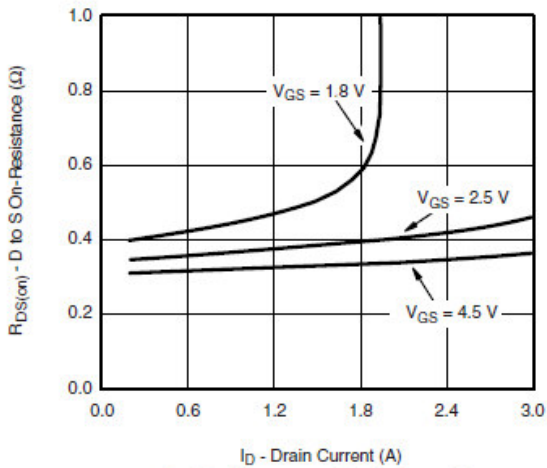

On-Resistance vs. Drain Current

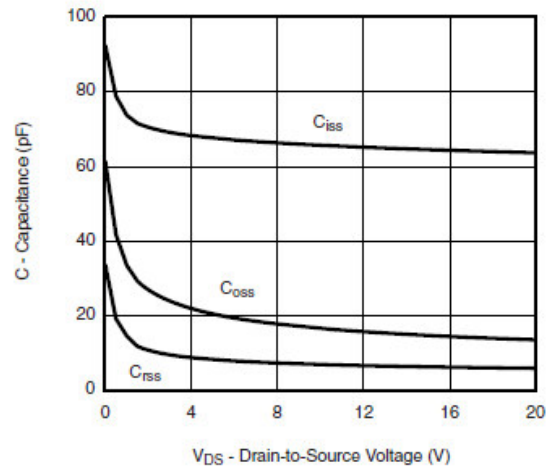

Capacitance

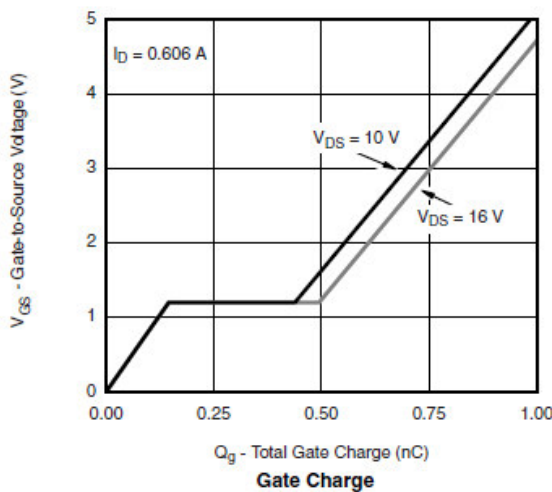

Gate Charge

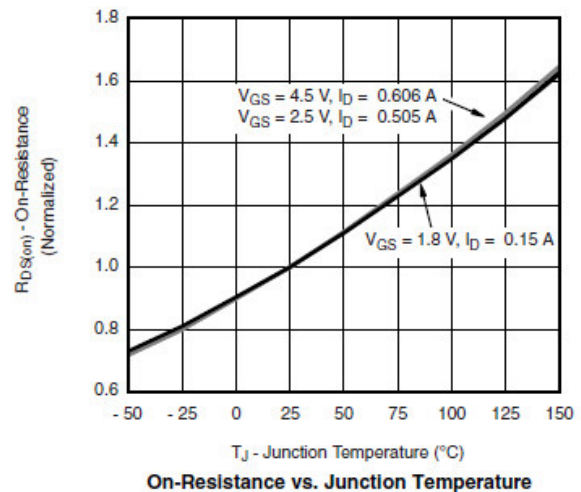

On-Resistance vs. Junction Temperature

Typical Performance Characteristics (continue)

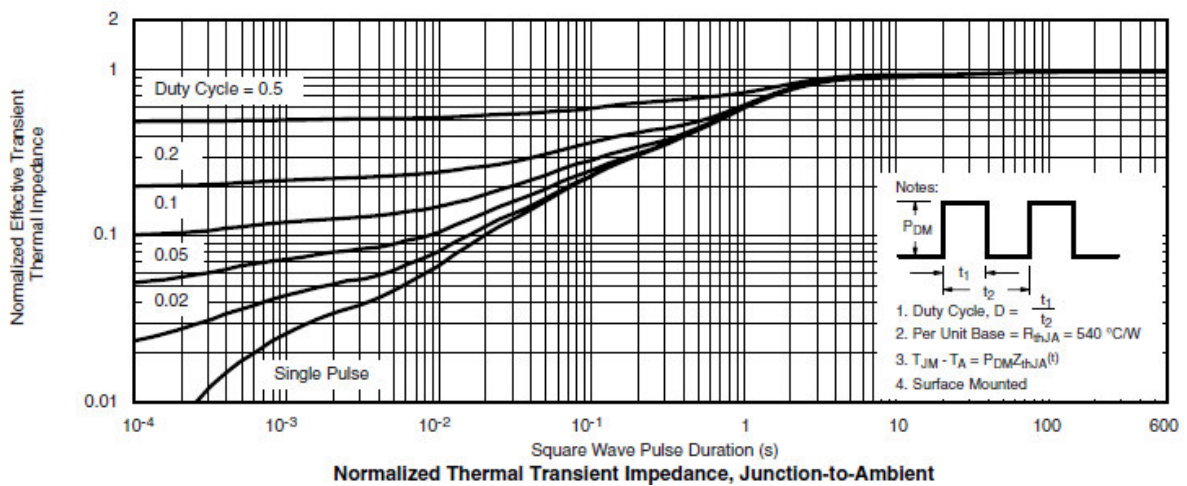
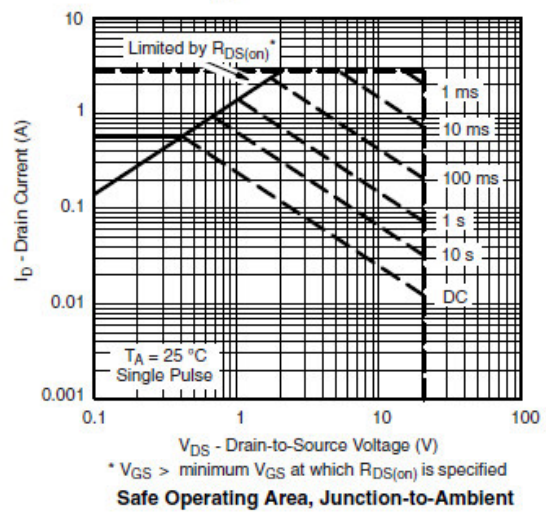
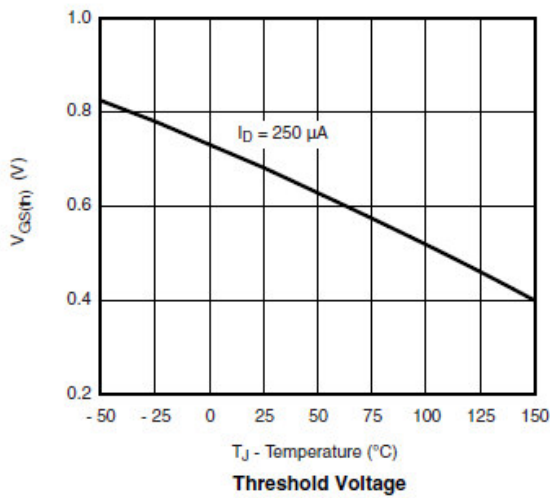
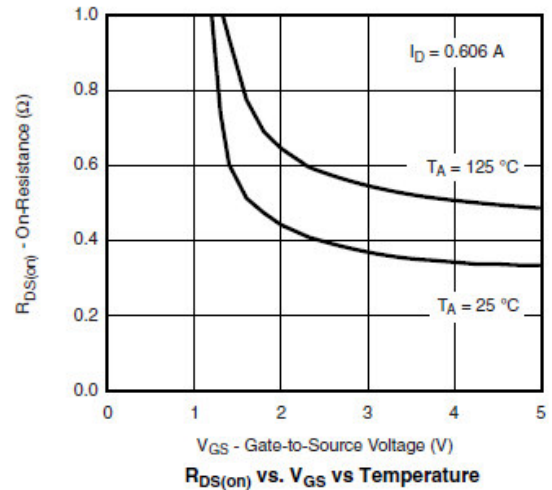
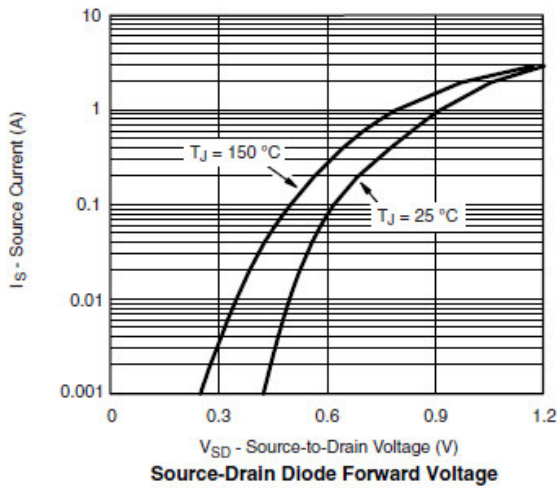

Typical Characteristics

Gate Charge Test Circuit & Waveform

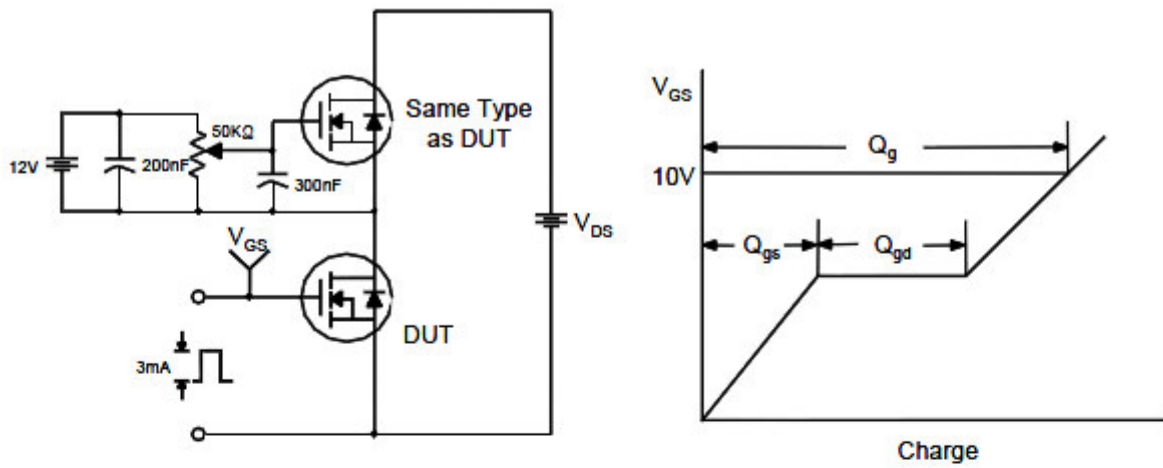

Resistive Switching Test Circuit & Waveforms

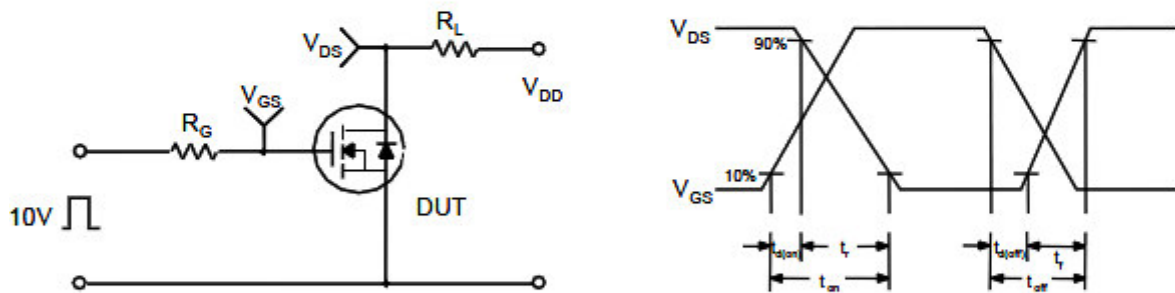

Unclamped Inductive Switching Test Circuit & Waveforms

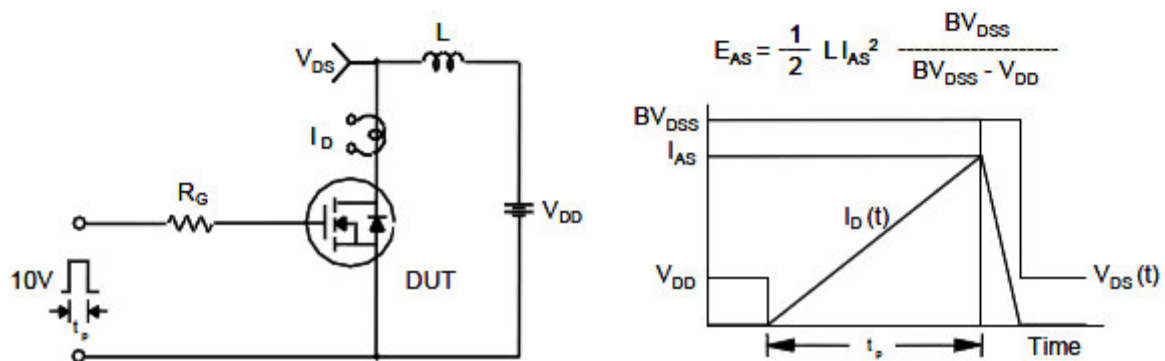

Package Dimension

SOT-323 PLASTIC PACKAGE

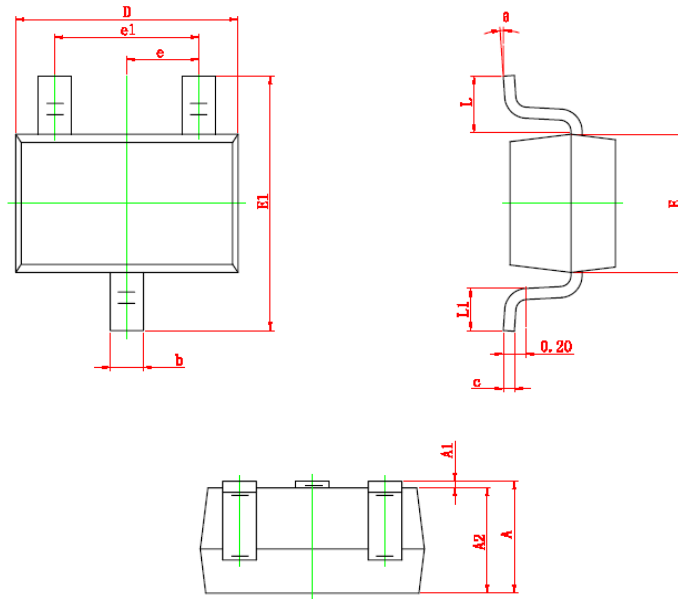





Dimensions				
Symbol	Millimeters		Inches	
	Min	Max	Min	Max
A	0.900	1.100	0.035	0.043
A1	0.000	0.100	0.000	0.004
A2	0.900	1.000	0.035	0.039
b	0.200	0.400	0.008	0.016
c	0.080	0.150	0.003	0.006
D	2.000	2.200	0.079	0.087
E	1.150	1.350	0.045	0.053
E1	2.150	2.450	0.085	0.096
e	0.650 TYP		0.026 TYP	
e1	1.200	1.400	0.047	0.055
L	0.525 REF		0.021 REF	
L1	0.260	0.460	0.010	0.018
θ	0°	8°	0°	8°



NOTICE

Information furnished is believed to be accurate and reliable. However Globaltech Semiconductor assumes no responsibility for the consequences of use of such information nor for any infringement of patents or other rights of third parties, which may result from its use. No license is granted by implication or otherwise under any patent or patent rights of Globaltech Semiconductor. Specifications mentioned in this publication are subject to change without notice. This publication supersedes and replaces all information without express written approval of Globaltech Semiconductor.

CONTACT US

GS Headquarter	
	4F.,No.43-1,Lane11,Sec.6,Minquan E.Rd NeiHu District Taipei City 114, Taiwan (R.O.C)
	886-2-2657-9980
	886-2-2657-3630
	sales_twn@gs-power.com

Wu-Xi Branch	
	No.21 Changjiang Rd., WND, Wuxi, Jiangsu, China (INFO. & TECH. Science Park Building A 210 Room)
	86-510-85217051
	86-510-85211238
	sales_cn@gs-power.com

RD Division	
	824 Bolton Drive Milpitas. CA. 95035
	1-408-457-0587