



SB30100LFYT

LOW VF SCHOTTKY BARRIER RECTIFIER

VOLTAGE 100 Volts **CURRENT** 30 Amperes

ITO-220AB

Unit : inch(mm)

FEATURES

- Low forward voltage drop, low power losses
- High efficiency operation
- In compliance with EU RoHS 2002/95/EC directives

MECHANICAL DATA

- Case : ITO-220AB, Plastic
- Terminals : Solderable per MIL-STD-750, Method 2026
- Weight : 0.055 ounces, 1.5615 grams

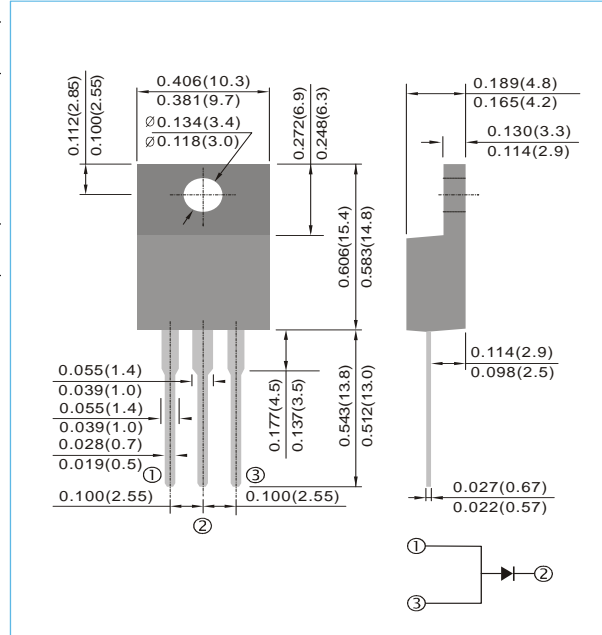

MAXIMUM RATINGS ($T_A=25\text{ }^\circ\text{C}$ unless otherwise noted)

PARAMETER	SYMBOL	VALUE	UNIT
Maximum repetitive peak reverse voltage	V_{RRM}	100	V
Maximum average forward rectified current (Fig.1)	$I_{F(AV)}$	30 15	A
Peak forward surge current 8.3ms single half sine-wave superimposed on rated load per diode	I_{FSM}	275	A
Typical thermal resistance	$R_{\theta Jc}$	4.5	$^\circ\text{C} / \text{W}$
Operating junction	T_J	-55 to + 150	$^\circ\text{C}$
Storage temperature range	T_{STG}	-55 to + 150	$^\circ\text{C}$

ELECTRICAL CHARACTERISTICS ($T_A=25\text{ }^\circ\text{C}$ unless otherwise noted)

PARAMETER	SYMBOL	TEST CONDITIONS	MIN.	TYP.	MAX.	UNIT
Breakdown voltage	V_{BR}	$I_R=1.0\text{mA}$	103	120	-	V
Instantaneous forward voltage per diode (Note 1)	V_F	$I_F=5\text{A}$ $I_F=15\text{A}$ $I_F=30\text{A}$	- - -	0.50 0.71 -	- - 1.00	V
Reverse current per diode (Note 2)	I_R	$V_R=70\text{V}$	-	10	-	μA
		$V_R=100\text{V}$	-	-	200	μA

Notes :

- 1 Pulse test : 380 μs pulse width, 1% duty cycle
2. Pulse test : Pulse width $\leq 2.5\text{ms}$



SB30100LFYT

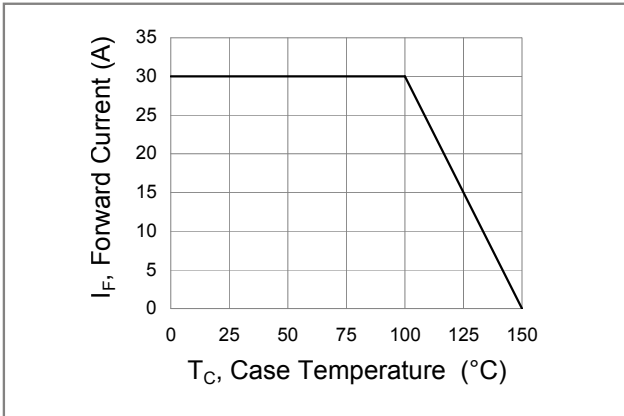

Fig.1 Forward Current Derating Curve

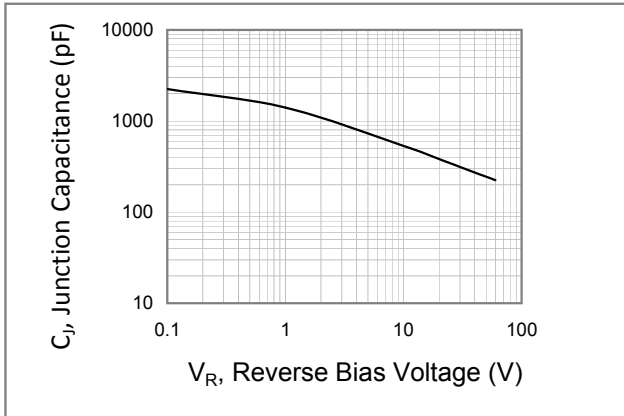

Fig.2 Typical Junction Capacitance

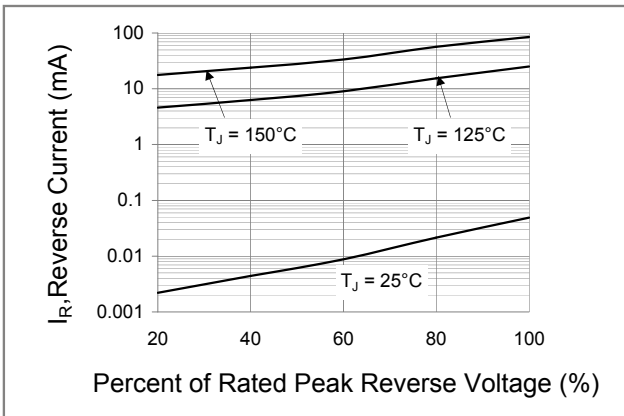

Fig.3 Typical Reverse Characteristics

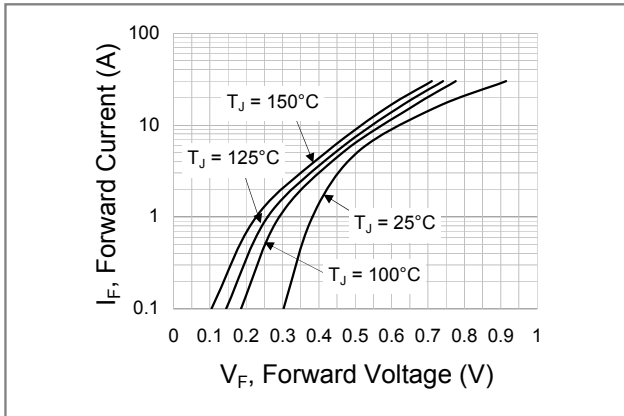

Fig.4 Typical Forward Characteristics