



SB1060LFCT

DUAL LOW VF SCHOTTKY RECTIFIER

VOLTAGE 60 Volts **CURRENT** 10 Amperes

FEATURES

- Low forward voltage drop, low power losses
- High efficiency operation
- In compliance with EU RoHS 2002/95/EC directives

MECHANICAL DATA

Case : ITO-220AB, Plastic

Terminals : Solderable per MIL-STD-750, Method 2026

Weight: 0.055 ounces, 1.561 grams

ITO-220AB Unit : inch(mm)

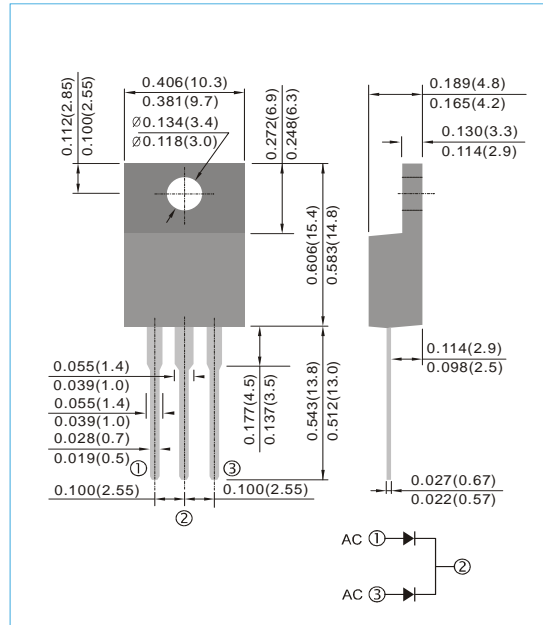

MAXIMUM RATINGS($T_A=25^{\circ}\text{C}$ unless otherwise noted)

PARAMETER	SYMBOL	VALUE	UNIT
Maximum repetitive peak reverse voltage	V_{RRM}	60	V
Maximum average forward rectified current (Fig.1)	$I_{F(AV)}$	10 5	A
Peak forward surge current 8.3ms single half sine-wave superimposed on rated load per diode	I_{FSM}	125	A
Typical thermal resistance	$R_{\theta JC}$	4.5	$^{\circ}\text{C} / \text{W}$
Operating junction	T_J	-55 to + 125	$^{\circ}\text{C}$
Storage temperature range	T_{STG}	-55 to + 150	$^{\circ}\text{C}$

ELECTRICAL CHARACTERISTICS($T_A=25^{\circ}\text{C}$ unless otherwise noted)

PARAMETER	SYMBOL	TEST CONDITIONS	MIN.	TYP.	MAX.	UNIT
Breakdown voltage	V_{BR}	$I_R=1\text{mA}$	68	-	-	V
Instantaneous forward voltage per diode ⁽¹⁾	V_F	$I_F=2.5\text{A}$ $I_F=5\text{A}$	-	0.40 0.45	-	V
		$I_F=2.5\text{A}$ $I_F=5\text{A}$	-	0.30 0.39	-	V
Reverse current per diode ⁽²⁾	I_R	$V_R=60\text{V}$	-	200 -	500 30	μA mA

Note.1.Pulse test : 300 μs pulse width, 1% duty cycle

2Pulse test : pulse width \leq 40ms



SB1060LFCT

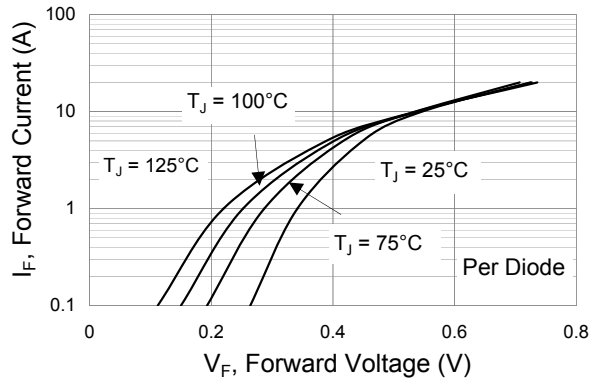

Fig.1 Typical Forward Characteristics

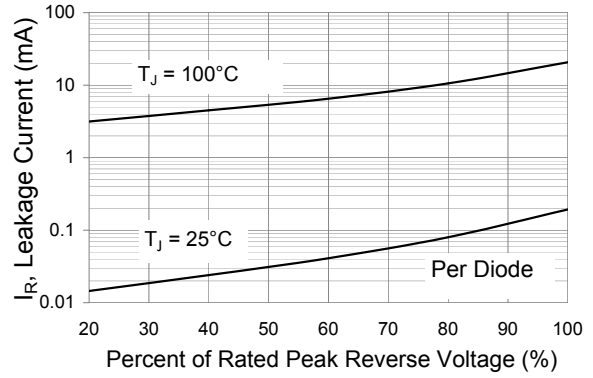

Fig.2 Typical Reverse Characteristics

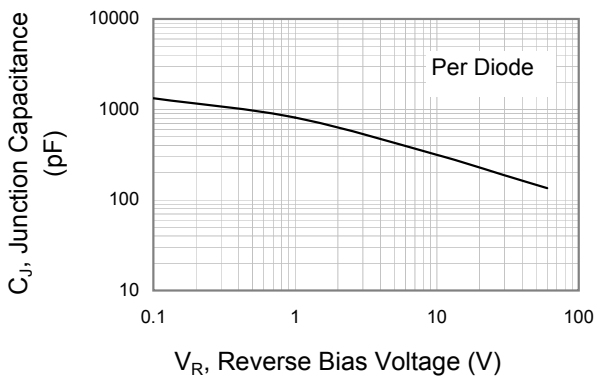

Fig.3 Typical Junction Capacitance

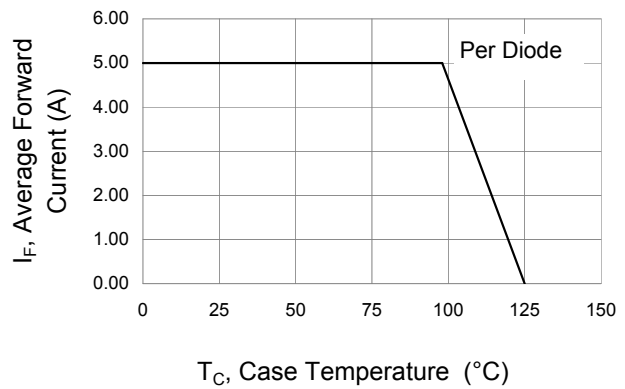

Fig.4 Forward Current Derating Curve