

DIGITRON SEMICONDUCTORS

MAC310(A) SERIES

SILICON BIDIRECTIONAL THYRISTORS

Available Non-RoHS (standard) or RoHS compliant (add PBF suffix).

Available as "HR" (high reliability) screened per MIL-PRF-19500, JANTX level. Add "HR" suffix to base part number.

MAXIMUM RATINGS ($T_C = 25^\circ\text{C}$ unless otherwise noted)

Rating	Symbol	Value	Unit
Peak repetitive off-state voltage ⁽¹⁾ ($T_J = -40$ to $+110^\circ\text{C}$, $\frac{1}{2}$ sine wave, 50 to 60Hz, gate open) MAC310-4, MAC310A-4 MAC310-6, MAC310A-6 MAC310-8, MAC310A-8	V_{DRM}	200 400 600	Volts
RMS on-state current (Full cycle sine wave, 50 to 60Hz, $T_C = 80^\circ\text{C}$)	$I_{\text{T(RMS)}}$	10	Amps
Peak non-repetitive surge current (1 cycle, 60Hz, $T_J = 110^\circ\text{C}$)	I_{TSM}	100	Amps
Circuit fusing considerations ($t = 8.3\text{ms}$)	I^2t	40	A^2s
Peak gate current ($t \leq 2\mu\text{s}$)	I_{GM}	± 2	Amps
Peak gate voltage ($t \leq 2\mu\text{s}$)	V_{GM}	± 10	Volts
Peak gate power ($t \leq 2\mu\text{s}$)	P_{GM}	20	Watts
Average gate power ($T_C = 80^\circ\text{C}$, $t \leq 8.3\text{ms}$)	$P_{\text{G(AV)}}$	0.5	Watts
Operating junction temperature range	T_J	-40 to +110	$^\circ\text{C}$
Storage temperature range	T_{stg}	-40 to +150	$^\circ\text{C}$
Mounting torque		8	In. lb.

Note 1: V_{DRM} for all types can be applied on a continuous basis. Blocking voltages shall not be tested with a constant current source such that the voltage ratings of the devices are exceeded.

THERMAL CHARACTERISTICS

Characteristic	Symbol	Maximum	Unit
Thermal resistance, junction to case	$R_{\theta\text{JC}}$	2.2	$^\circ\text{C}/\text{W}$
Thermal resistance, junction to ambient	$R_{\theta\text{JA}}$	60	$^\circ\text{C}/\text{W}$

ELECTRICAL CHARACTERISTICS ($T_C = 25^\circ\text{C}$ and either polarity of MT2 to MT1 voltage unless otherwise noted)

Characteristic	Symbol	Min	Typ.	Max	Unit
Peak blocking current ($V_D = \text{Rated } V_{\text{DRM}}$, gate open, $T_J = 25^\circ\text{C}$) ($V_D = \text{Rated } V_{\text{DRM}}$, gate open, $T_J = 110^\circ\text{C}$)	I_{DRM}	-	-	10 2	mA mA
Peak on-state voltage ($I_{\text{TM}} = 14\text{A}$ peak, pulse width $\leq 2\text{ms}$, duty cycle $\leq 2\%$.)	V_{TM}	-	-	2.0	Volts
Gate trigger current (continuous dc) ($V_D = 12\text{V}$, $R_L = 100\Omega$) MT2(+),G(+); MT2(+),G(-); MT2(-),G(-) MT2(-),G(+) "A" suffix only	I_{GT}	-	-	5 10	mA
Gate trigger voltage (continuous dc) ($V_D = 12\text{V}$, $R_L = 100\Omega$) MT2(+),G(+); MT2(+),G(-); MT2(-),G(-) MT2(-),G(+) "A" suffix only ($V_D = \text{Rated } V_{\text{DRM}}$, $R_L = 10\text{k}\Omega$, $T_C = 110^\circ\text{C}$) All Types	V_{GT}	-	-	2.0 2.5 0.2	Volts
Holding current ($V_D = 12\text{V}$, $I_{\text{TM}} = 200\text{mA}$, gate open)	I_{H}	-	-	15	mA
Gate controlled turn-on time ($V_D = \text{Rated } V_{\text{DRM}}$, $I_{\text{TM}} = 14\text{A}$, $I_{\text{G}} = 30\text{mA}$)	t_{gt}	-	1.5	-	μs
Critical rate of rise of off-state voltage ($V_D = \text{Rated } V_{\text{DRM}}$, exponential waveform, $T_C = 110^\circ\text{C}$)	dv/dt	-	25	-	$\text{V}/\mu\text{s}$

DIGITRON SEMICONDUCTORS

MAC310(A) SERIES

SILICON BIDIRECTIONAL THYRISTORS

Characteristic	Symbol	Min	Typ.	Max	Unit
Critical rate of rise of commutation voltage ($V_D = \text{Rated } V_{DRM}, I_{TM} = 14A \text{ peak, commutating } di/dt = 5A/ms, \text{ gate unenergized, } T_C = 80^\circ C$)	dv/dt(c)	-	5	-	V/ μ s

MECHANICAL CHARACTERISTIC

Case	TO-220AB
Marking	Alpha-numeric
Pin out	See below

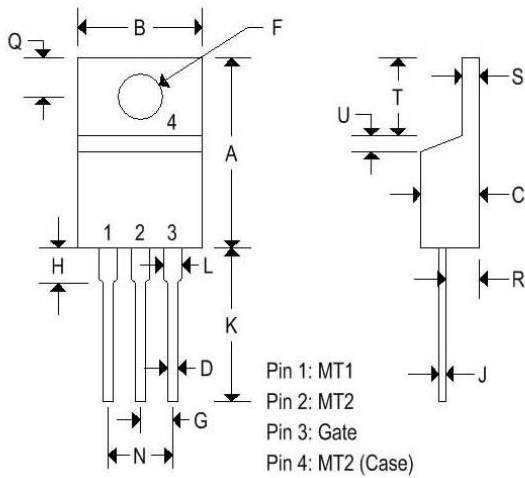

	TO-220AB			
	Inches		Millimeters	
	Min	Max	Min	Max
A	0.575	0.620	14.600	15.750
B	0.380	0.405	9.650	10.290
C	0.160	0.190	4.060	4.820
D	0.025	0.035	0.640	0.890
F	0.142	0.147	3.610	3.730
G	0.095	0.105	2.410	2.670
H	0.110	0.155	2.790	3.930
J	0.014	0.022	0.360	0.560
K	0.500	0.562	12.700	14.270
L	0.045	0.055	1.140	1.390
N	0.190	0.210	4.830	5.330
Q	0.100	0.120	2.540	3.040
R	0.080	0.110	2.040	2.790
S	0.045	0.055	1.140	1.390
T	0.235	0.255	5.970	6.480
U	-	0.050	-	1.270
V	0.045	-	1.140	-
Z	-	0.080	-	2.030

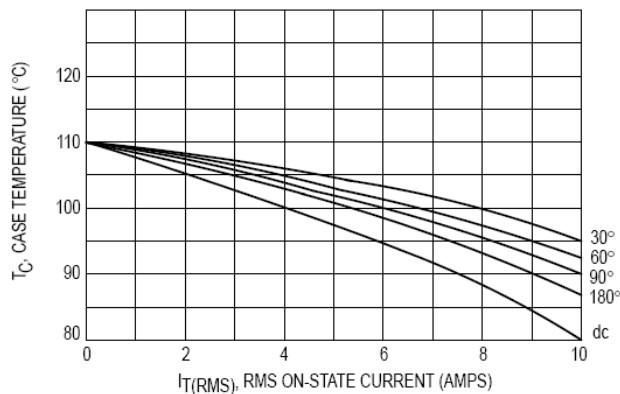

Figure 1. RMS Current Derating

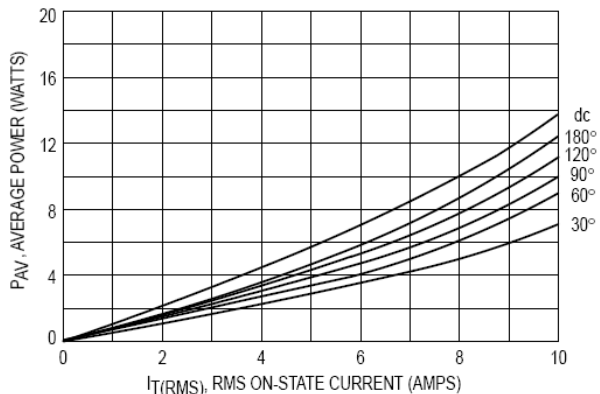

Figure 2. On-State Power Dissipation