

DIGITRON SEMICONDUCTORS

MAC94(A) SERIES

SILICON BIDIRECTIONAL THYRISTORS

Available Non-RoHS (standard) or RoHS compliant (add PBF suffix).

Available as "HR" (high reliability) screened per MIL-PRF-19500, JANTX level. Add "HR" suffix to base part number.

MAXIMUM RATINGS

Rating	Symbol	Value	Unit
Peak repetitive off-state voltage ($T_J = -40$ to 125°C , $\frac{1}{2}$ sine wave 50 to 60Hz, gate open) MAC94(A)-1 MAC94(A)-2 MAC94(A)-3 MAC94(A)-4	V_{DRM}	30 60 100 200	Volts
RMS on-state current (full cycle sine wave 50 to 60Hz, $T_C = 60^\circ\text{C}$)	$I_{\text{T(RMS)}}$	0.8	Amps
Peak non-repetitive surge current (1 cycle, 60Hz, $T_J = 60^\circ\text{C}$, preceded and followed by rated current)	I_{TSM}	6.0	Amps
Circuit fusing considerations ($T_J = -40$ to $+125^\circ\text{C}$, $t = 8.3\text{ms}$)	I^2t	0.15	A^2s
Average gate power	$P_{\text{G(AV)}}$	0.01	Watts
Peak gate current	I_{GM}	1.0	Amps
Operating junction temperature range	T_J	-40 to +125	$^\circ\text{C}$
Storage temperature range	T_{stg}	-40 to +150	$^\circ\text{C}$

THERMAL CHARACTERISTICS

Characteristic	Symbol	Maximum	Unit
Thermal resistance, junction to case	R_{eJC}	75	$^\circ\text{C}/\text{W}$
Thermal resistance, junction to ambient	R_{eJA}	200	$^\circ\text{C}/\text{W}$

ELECTRICAL CHARACTERISTICS ($T_C = 25^\circ\text{C}$ unless otherwise noted)

Characteristic	Symbol	Min	Typ.	Max	Unit
Peak blocking current (either direction) ($V_D = \text{Rated } V_{\text{DRM}}$, $T_J = 125^\circ\text{C}$, gate open)	I_{DRM}	-	-	2.0	mA
Peak on-state voltage (either direction) ($I_{\text{TM}} = 1.12\text{A}$ peak, pulse width = 1 to 2ms, duty cycle $\leq 2\%$)	V_{TM}	-	-	1.5	Volts
Gate trigger current (continuous dc) ($V_D = 7\text{V}$, $R_L = 100\Omega$, minimum gate pulse width = $2\mu\text{s}$) MT2(+),G(+); MT2(-),G(-), all devices MT2(+),G(-); MT2(-),G(+), MAC94A-1 through MAC94A-4	I_{GT}	-	-	5.0 10	mA
Gate trigger voltage (continuous dc) ($V_D = 7\text{V}$, $R_L = 100\Omega$, minimum gate pulse width = $2\mu\text{s}$) MT2(+),G(+); MT2(-),G(-), all devices MT2(+),G(-); MT2(-),G(+), MAC94A-1 through MAC94A-4 MT2(+),G(+); MT2(-),G(-), $T_C = -40^\circ\text{C}$, all devices MT2(+),G(-); MT2(-),G(+), $T_C = -40^\circ\text{C}$, MAC94A-1 through MAC94A-4 ($V_D = \text{Rated } V_{\text{DRM}}$, $R_L = 10\text{k}\Omega$, $T_J = 125^\circ\text{C}$) MT2(+),G(+); MT2(-),G(-), all devices MT2(+),G(-); MT2(-),G(+), MAC94A-1 through MAC94A-4	V_{GT}	-	-	2.0 2.0 3.0 3.0	Volts
Holding current (either direction) ($V_D = 7\text{V}$, $I_{\text{TM}} = 20\text{mA}$, gate open, $T_C = 25^\circ\text{C}$) ($V_D = 7\text{V}$, $I_{\text{TM}} = 20\text{mA}$, gate open, $T_C = -40^\circ\text{C}$)	I_{H}	-	-	10 20	mA

DIGITRON SEMICONDUCTORS

MAC94(A) SERIES

SILICON BIDIRECTIONAL THYRISTORS

MECHANICAL CHARACTERISTIC

Case	TO-92
Marking	Alpha-numeric
Pin out	See below

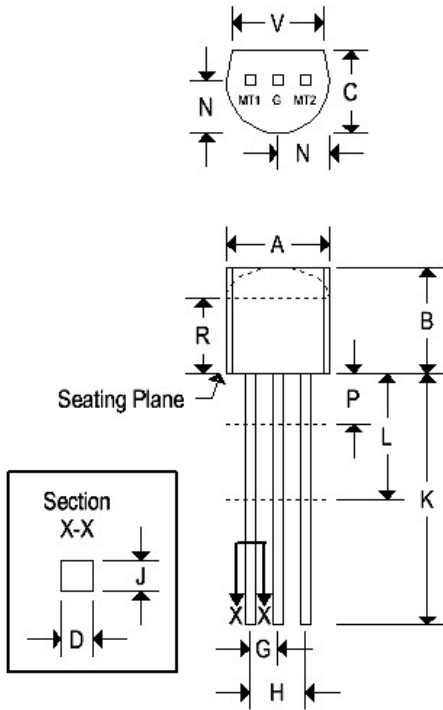

	TO-92			
	Inches		Millimeters	
	Min	Max	Min	Max
A	0.175	0.205	4.450	5.200
B	0.170	0.210	4.320	5.330
C	0.125	0.165	3.180	4.190
D	0.016	0.022	0.410	0.550
F	0.016	0.019	0.410	0.480
G	0.045	0.055	1.150	1.390
H	0.095	0.105	2.420	2.660
J	0.015	0.020	0.390	0.500
K	0.500	-	12.700	-
L	0.250	-	6.350	-
N	0.080	0.105	2.040	2.660
P	-	0.100	-	2.540
R	0.115	-	2.930	-
V	0.135	-	3.430	-

FIGURE 1 – TYPICAL GATE TRIGGER VOLTAGE

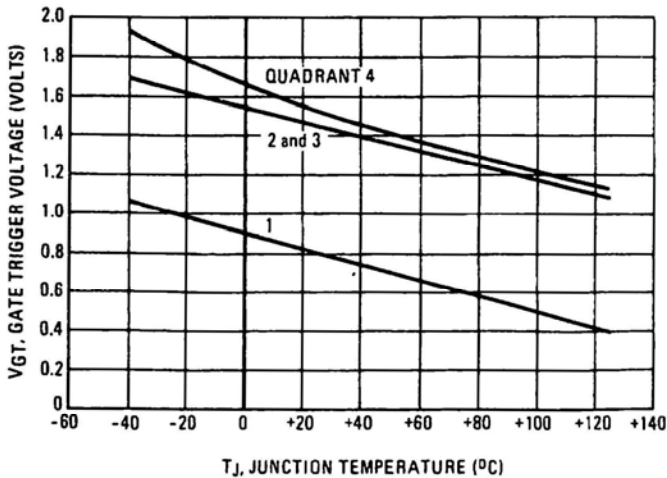
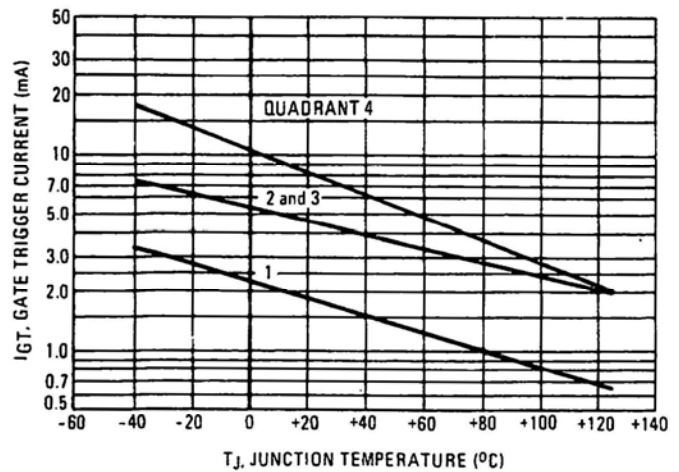

FIGURE 2 – TYPICAL GATE TRIGGER CURRENT



DIGITRON SEMICONDUCTORS

MAC94(A) SERIES SILICON BIDIRECTIONAL THYRISTORS

**FIGURE 3 – AVERAGE CURRENT DERATING
(REFERENCE: CASE TEMPERATURE)**

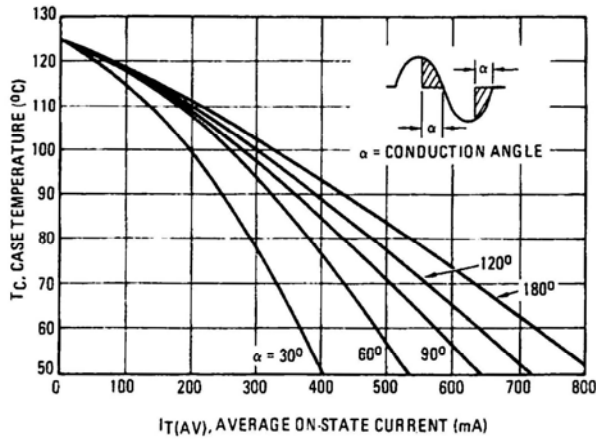

**FIGURE 4 – RMS CURRENT DERATING
(REFERENCE: CASE TEMPERATURE)**

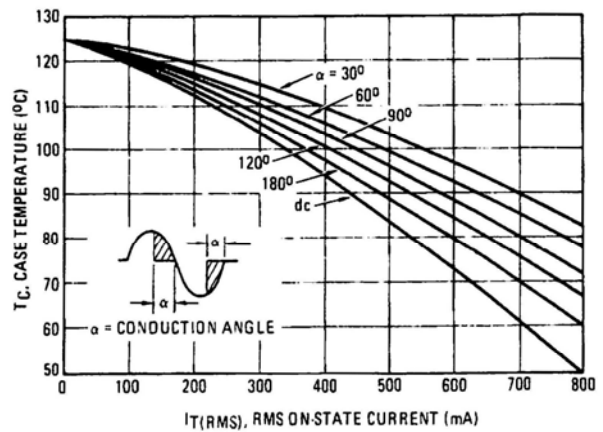

**FIGURE 5 – AVERAGE CURRENT DERATING
(REFERENCE: AMBIENT TEMPERATURE)**

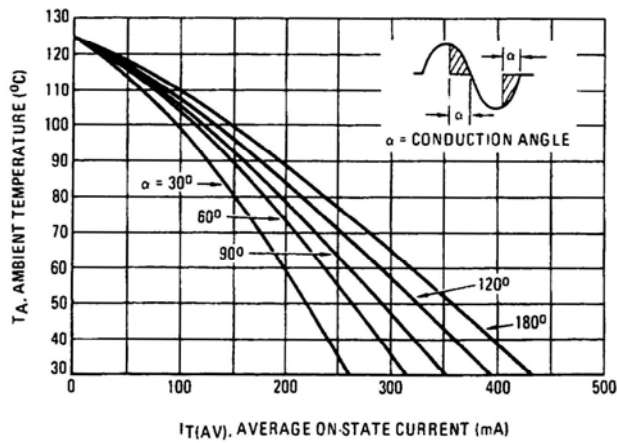

**FIGURE 6 – RMS CURRENT DERATING
(REFERENCE: AMBIENT TEMPERATURE)**

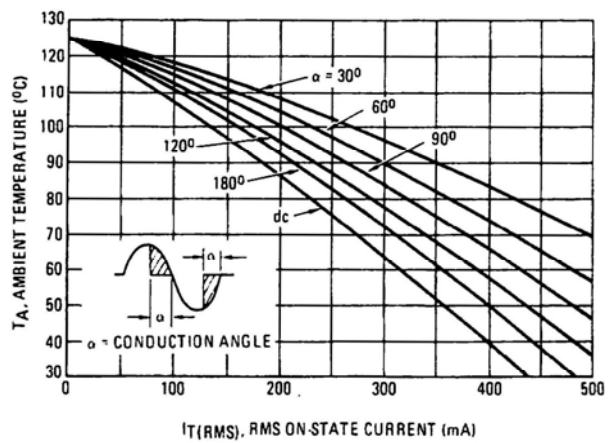

FIGURE 7 – ON-STATE POWER DISSIPATION

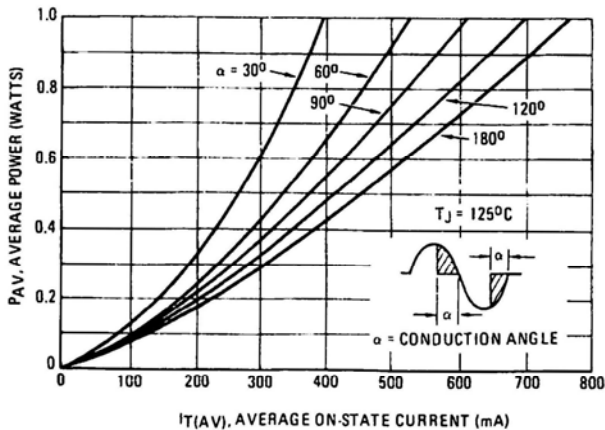
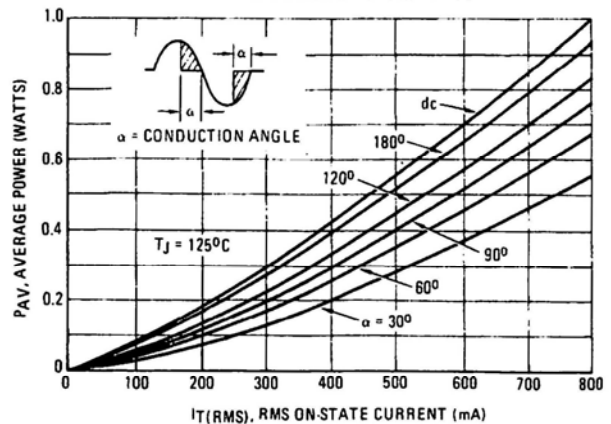

FIGURE 8 – ON-STATE POWER DISSIPATION



DIGITRON SEMICONDUCTORS

MAC94(A) SERIES SILICON BIDIRECTIONAL THYRISTORS

FIGURE 9 – MAXIMUM ON STATE CHARACTERISTICS

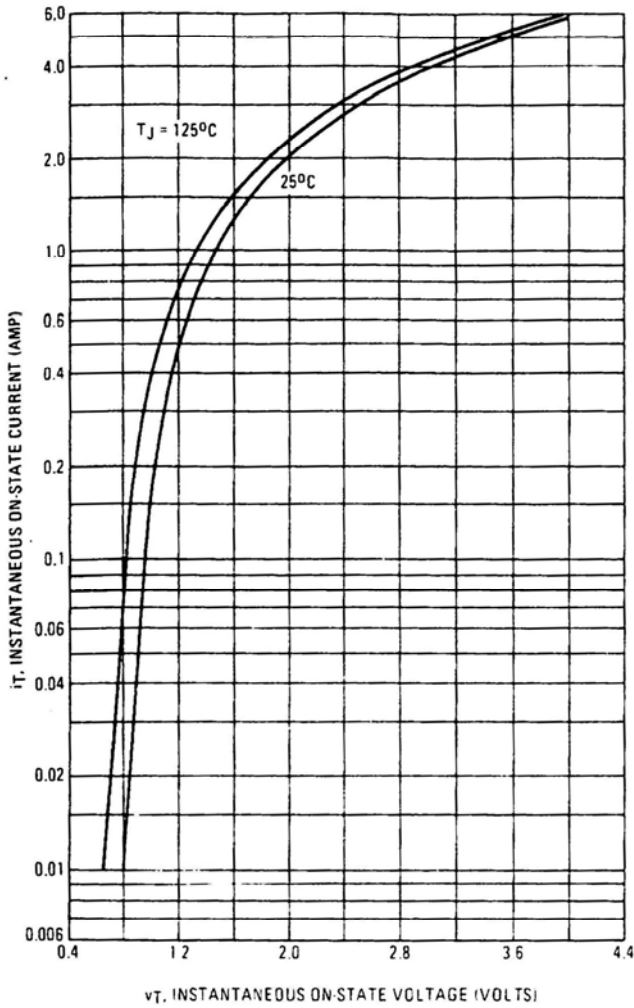

FIGURE 10 – TYPICAL HOLDING CURRENT

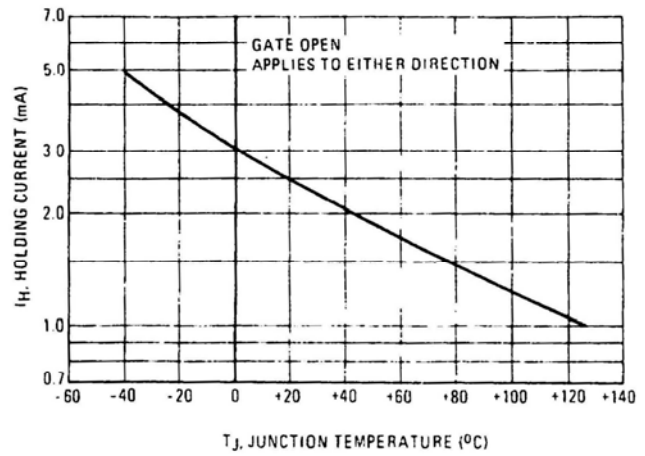

FIGURE 11 – MAXIMUM NON-REPETITIVE SURGE CURRENT

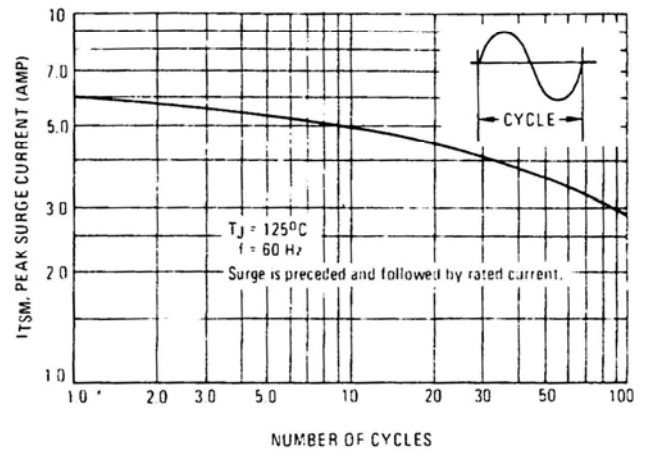

FIGURE 12 – THERMAL RESPONSE

