

HTB1A80AS

1A TRIAC

FEATURES

- Repetitive Peak Off-State Voltage : 1000V
- R.M.S On-State Current ($I_{T(RMS)} = 1A$)
- Gate Trigger Current : 5mA
- $dV/dt \geq 400V/\mu s$

General Description

Intended for use in AC static switching and industrial control systems, driving low power highly inductive load like solenoid, pump, fan and micro-motor.

$$V_{DRM} = 1000 V$$

$$I_{T(RMS)} = 1 A$$

$$I_{TSM} = 11 A$$

$$I_{GT} = 5mA$$

Symbol

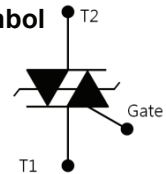

TO-92



Absolute Maximum Ratings ($T_J=25^\circ C$ unless otherwise specified)

Symbol	Parameter	Conditions	Ratings	Unit
V_{DRM}	Repetitive Peak Off-State Voltage	Sine wave, 50/60Hz, Gate open	1000	V
V_{RRM}	Repetitive Peak Reverse Voltage		1000	V
V_{DSM}	Non-Repetitive Surge Peak Off-State Voltage		1100	V
V_{RSM}	Non-Repetitive Peak Reverse Voltage		1100	V
$I_{T(RMS)}$	R.M.S. On-State Current	Full sine wave, $T_C = 57^\circ C$	1	A
I_{TSM}	Non-Repetitive Surge Peak On-State Current	Full sine wave, 50Hz/60Hz	10/11	A
I^2t	Fusing Current	$t = 10ms$	1.12	A ² S
P_{GM}	Forward Peak Gate Power Dissipation	$T_J = 125^\circ C$	1	W
$P_{G(AV)}$	Forward Average Gate Power Dissipation	$T_J = 125^\circ C$	1	W
I_{GM}	Peak Gate Current	$tp=20\mu s, T_J = 125^\circ C$	1	A
T_J	Operating Junction Temperature		-40~+125	$^\circ C$
T_{STG}	Storage Temperature		-40~+150	$^\circ C$

Electrical Characteristics ($T_J=25^\circ\text{C}$ unless otherwise specified)

Symbol	Parameter	Conditions	Min	Typ	Max	Unit	
I_{DRM}	Repetitive Peak Off-State Current	$V_D = V_{\text{DRM}}$	$T_J=25^\circ\text{C}$	-	-	10	μA
			$T_J=125^\circ\text{C}$	-	-	500	μA
I_{RRM}	Repetitive Peak Reverse Current	$V_R = V_{\text{RRM}}$	$T_J=25^\circ\text{C}$	-	-	10	μA
			$T_J=125^\circ\text{C}$	-	-	500	μA
I_{GT}	Gate Trigger Current	$V_D = 12\text{V}, R_L=30\Omega$	1+	-	-	3	mA
			1-, 3-	-	-	5	mA
V_{GT}	Gate Trigger Voltage	$V_D = 12\text{V}, R_L=30\Omega$	1+, 1-, 3-	-	-	1.4	V
V_{GD}	Non-Trigger Gate Voltage	$V_D = 2/3V_{\text{DRM}}, R_L=3.3\text{K}\Omega,$ $T_J=125^\circ\text{C}$	0.2	-	-	V	
I_L	Latching Current	$I_G = 1.2I_{\text{GT}}$	1+, 3-	-	-	15	mA
			1-	-	-	25	mA
I_H	Holding Current	$I_T = 100\text{mA}$	-	-	10	mA	
V_{TM}	Peak On-State Voltage	$I_T = 1.4\text{A}, t_p = 380\mu\text{s}$	-	-	1.5	V	
dv/dt	Critical Rate of Rise of Off-State Voltage	$V_D = 2/3 V_{\text{DRM}},$ Gate open, $T_J=125^\circ\text{C}$	400	-	-	V/us	

Thermal Characteristics

Symbol	Parameter	Conditions	Min	Typ	Max	Unit
$R_{\theta\text{JC}}$	Thermal Resistance	Junction to Case			60	$^\circ\text{C/W}$

Typical Characteristics

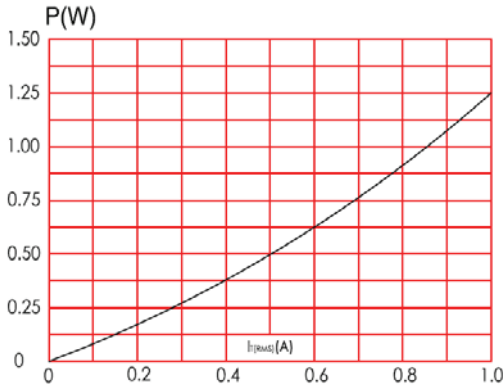

Fig 1. R.M.S. current vs. Power dissipation

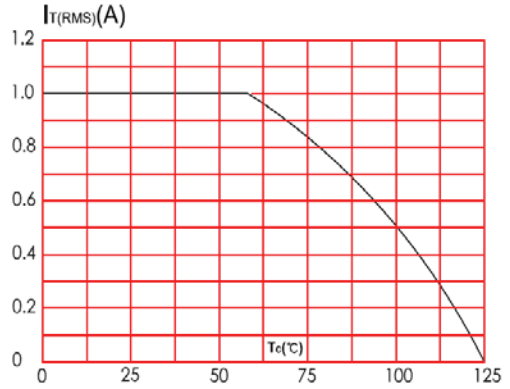

Fig 2. R.M.S. current vs. Case temperature

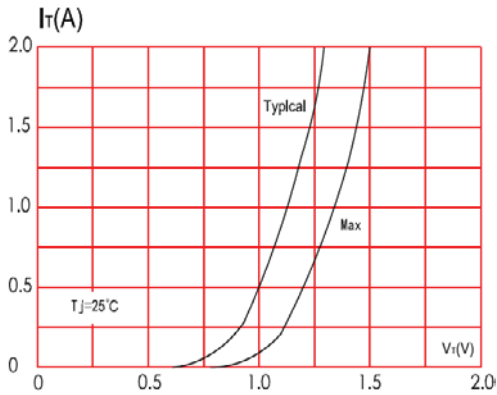

Fig 3. Surge on state characteristics

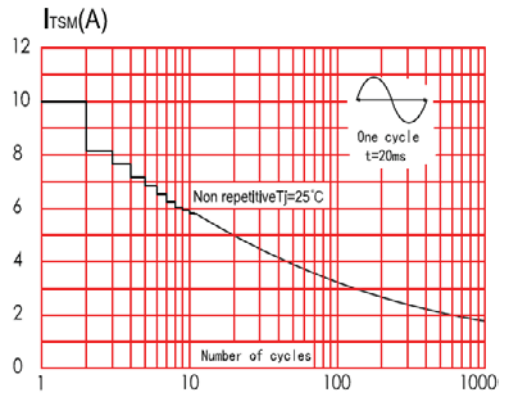

Fig 4. Surge on state current rating

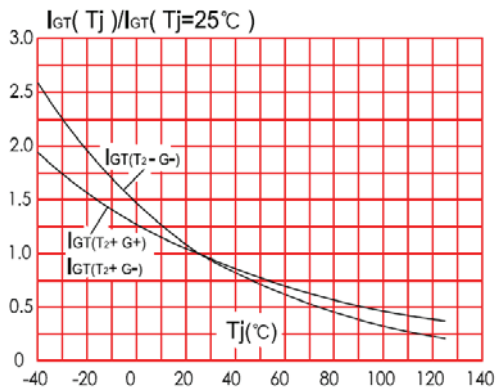

Fig 5. Gate trigger current vs. junction temperature

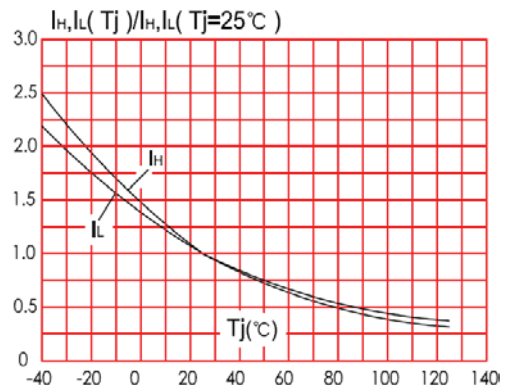
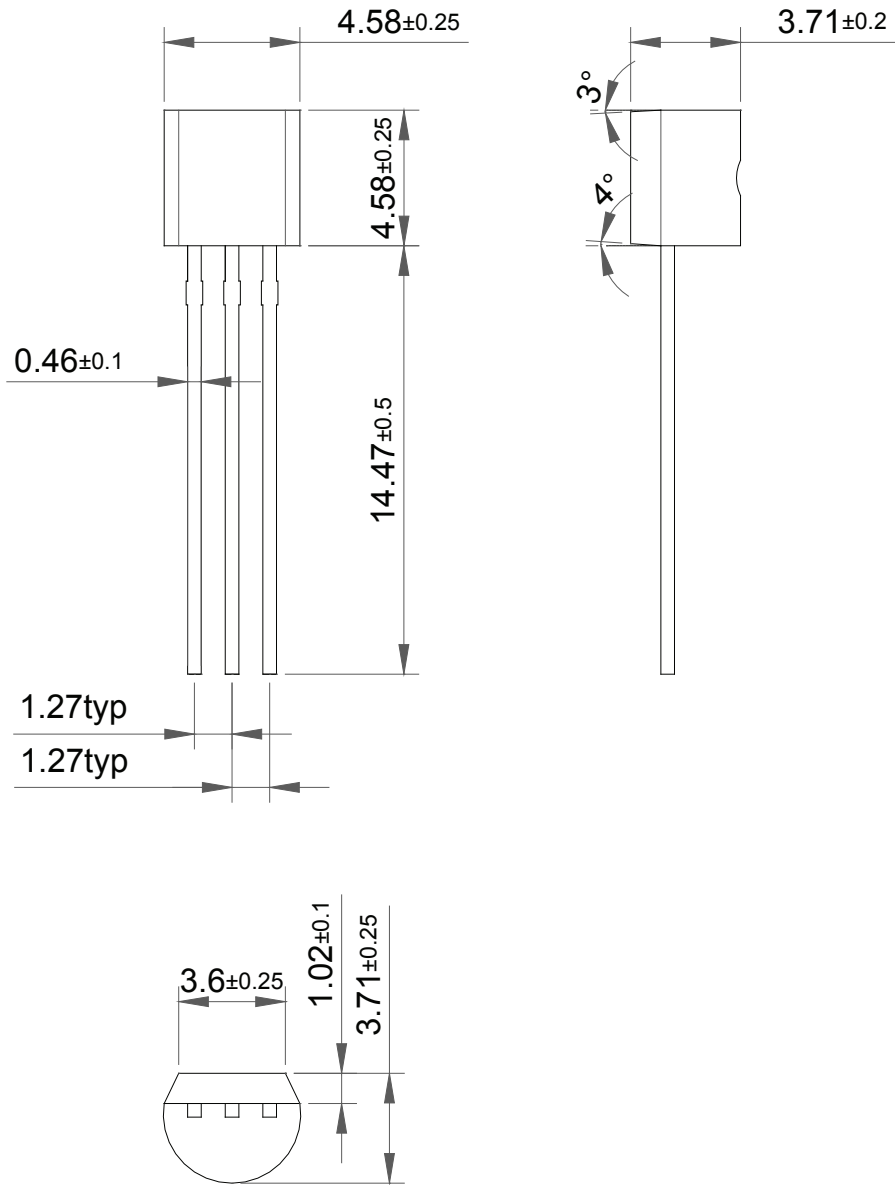

Fig 6. Holding and latching current vs. junction temperature

Package Dimension

TO-92 BULK



Package Dimension

TO-92 TAPING

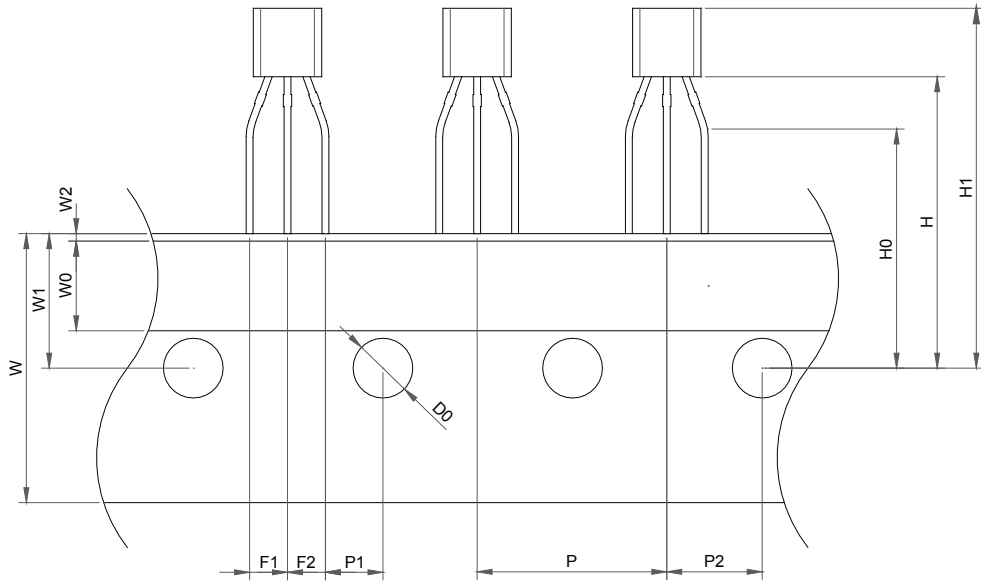

Item	Symbol	Dimension [mm]	
		Reference	Tolerance
Component pitch	P	12.7	±0.5
Side lead to center of feed hole	P1	3.85	±0.5
Center lead to center of feed hole	P2	6.35	±0.5
Lead pitch	F1,F2	2.5	+0.2/-0.1
Carrier Tape width	W	18.0	+1.0/-0.5
Adhesive tape width	W0	6.0	±0.5
Tape feed hole location	W1	9.0	±0.5
Adhesive tape position	W2	1.0 MAX	
Center of feed hole to bottom of component	H	19.5	±1
Center of feed hole to lead form	H0	16.0	±0.5
Component height	H1	27.0 max	
Tape feed hole diameter	D0	4.0	±0.2