



## BT169

SCR

### SCRS

#### DESCRIPTION

Passivated, sensitive gate thyristors in a plastic envelope, intended for use in general purpose switching and phase control applications. These devices are intended to be interfaced directly to microcontrollers, logic integrated circuits and other low power gate trigger circuits.

#### SYMBOL

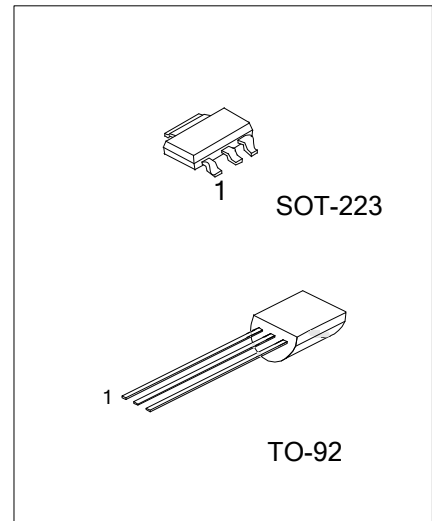
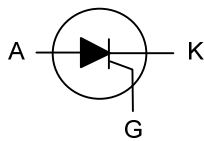

#### ORDERING INFORMATION

Ordering Number		Package	Pin Assignment			Packing
Lead Free	Halogen Free		1	2	3	
BT169BL-T92-B	BT169BG-T92-B	TO-92	K	G	A	Tape Box
BT169BL-T92-K	BT169BG-T92-K	TO-92	K	G	A	Bulk
BT169DL-T92-B	BT169DG-T92-B	TO-92	K	G	A	Tape Box
BT169DL-T92-K	BT169DG-T92-K	TO-92	K	G	A	Bulk
BT169EL-T92-B	BT169EG-T92-B	TO-92	K	G	A	Tape Box
BT169EL-T92-K	BT169EG-T92-K	TO-92	K	G	A	Bulk
BT169GL-T92-B	BT169GP-T92-B	TO-92	K	G	A	Tape Box
BT169GL-T92-K	BT169GP-T92-K	TO-92	K	G	A	Bulk
-	BT169HG-AA3-R	SOT-223	K	A	G	Tape Reel
BT169HL-T92-B	BT169HG-T92-B	TO-92	K	G	A	Tape Box
BT169HL-T92-K	BT169HG-T92-K	TO-92	K	G	A	Bulk

Note: Pin Assignment: K: Cathode G: Gate A: Anode

<p>BT169xG-AA3-R</p>	<p>(1) B: Tape Box, K: Bulk, R: Tape Reel  (2) AA3: SOT-223, T92: TO-92  (3) G: Halogen Free and Lead Free, L: Lead Free  P: Halogen Free(for BT169G)  (4) x: refer to Quick Reference data</p>
----------------------	---

■ MARKING

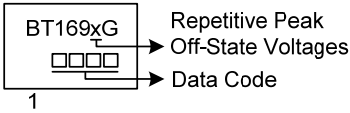
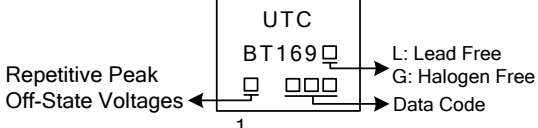
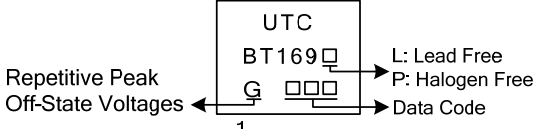
Package	MARKING
SOT-223	 <p>BT169xG            Repetitive Peak Off-State Voltages            Data Code            1</p>
TO-92	 <p>UTC            BT 169            L: Lead Free            G: Halogen Free            Data Code            Repetitive Peak Off-State Voltages            1</p>
TO-92 (For BT169G)	 <p>UTC            BT 169            G            P: Halogen Free            Data Code            Repetitive Peak Off-State Voltages            1</p>

## ■ QUICK REFERENCE DATA

PARAMETER	SYMBOL	BT169B	BT169D	BT169E	BT169G	BT169H	UNIT
		MAX	MAX	MAX	MAX	MAX	MAX
Repetitive Peak Off-State Voltages	$V_{DRM}, V_{RRM}$	200	400	500	600	800	V
Average On-State Current	$I_{T(AV)}$	0.5	0.5	0.5	0.5	0.5	A
RMS On-State Current	$I_{T(RMS)}$	0.8	0.8	0.8	0.8	0.8	A
Non-Repetitive Peak On-State Current	$I_{TSM}$	8	8	8	8	8	A

## ■ ABSOLUTE MAXIMUM RATINGS

PARAMETER		SYMBOL	RATINGS	UNIT
Repetitive Peak Off-State Voltages(Note 2)	BT169B	$V_{DRM}, V_{RRM}$	200	V
	BT169D		400	
	BT169E		500	
	BT169G		600	
	BT169H		800	
Peak Gate Voltage		$V_{GM}$	5	V
Peak Reverse Gate Voltage		$V_{RGM}$	5	V
Peak Gate Current		$I_{GM}$	1	A
Average On-State Current (Half Sine Wave, $T_{LEAD} \leq 83^{\circ}C$ )		$I_{T(AV)}$	0.5	A
RMS On-State Current (All Conduction Angles)		$I_{T(RMS)}$	0.8	A
Non-Repetitive Peak On-State Current (Half Sine Wave, $T_J=25^{\circ}C$ Prior to Surge)	$t=10ms$	$I_{TSM}$	8	A
	$t=8.3ms$		9	A
$I^2t$ For Fusing ( $t=10ms$ )		$I^2t$	0.32	$A^2S$
Repetitive Rate of Rise of On-State Current After Triggering ( $I_{TM}=2A, I_G=10mA, dI_G/dt=100mA/\mu s$ )		$dI_T/dt$	50	$A/\mu s$
Peak Gate Power		$P_{GM}$	2	W
Average Gate Power (Over any 20 ms period)		$P_{G(AV)}$	0.1	W
Junction Temperature		$T_J$	+125	$^{\circ}C$
Storage Temperature		$T_{STG}$	-40 ~ +150	$^{\circ}C$

Note: 1. Absolute maximum ratings are those values beyond which the device could be permanently damaged.

Absolute maximum ratings are stress ratings only and functional device operation is not implied.

2. 1 Although not recommended, off-state voltages up to 800V may be applied without damage, but the thyristor may switch to the on-state. The rate of rise of current should not exceed 15 A/ $\mu s$ .

## ■ THERMAL DATA

PARAMETER		SYMBOL	RATINGS	UNIT
Thermal Resistance Junction to Ambient (typ.)	SOT-223	$\theta_{JA}$	150	$^{\circ}C/W$
	TO-92		180	$^{\circ}C/W$

Note: pcb mounted, lead length=4mm

■ ELECTRICAL CHARACTERISTICS ( $T_J=25^\circ\text{C}$ , unless otherwise specified)

PARAMETER	SYMBOL	TSET CONDITIONS	MIN	TYP	MAX	UNIT
<b>STATIC CHARACTERISTICS</b>						
Gate Trigger Current	$I_{GT}$	$V_D=12\text{V}$ , $I_T=10\text{ mA}$ , gate open circuit	25		55	$\mu\text{A}$
Latching Current	$I_L$	$V_D=12\text{V}$ , $I_{GT}=0.5\text{mA}$ , $R_{GK}=1\text{k}\Omega$		2	6	mA
Holding Current	$I_H$	$V_D=12\text{V}$ , $I_{GT}=0.5\text{mA}$ , $R_{GK}=1\text{k}\Omega$		2	5	mA
On-State Voltage	$V_T$	$I_T=1\text{A}$		1.2	1.35	V
Gate Trigger Voltage	$V_{GT}$	$V_D=12\text{V}$ , $I_T=10\text{mA}$ , gate open circuit $V_D=V_{DRM(\text{MAX})}$ , $I_T=10\text{mA}$ , $T_J=125^\circ\text{C}$ , gate open circuit	0.2	0.5 0.3	0.8	V
Off-State Leakage Current	$I_D, I_R$	$V_D=V_{DRM(\text{MAX})}$ , $V_R=V_{RRM(\text{MAX})}$ , $T_J=125^\circ\text{C}$ , $R_{GK}=1\text{k}\Omega$		0.05	0.1	mA
<b>DYNAMIC CHARACTERISTICS</b>						
Critical Rate of Rise of Off-State Voltage	$dV_D/dt$	$V_{DM}=67\% V_{DRM(\text{MAX})}$ , $T_J=125^\circ\text{C}$ , exponential waveform, $R_{GK}=1\text{k}\Omega$	500	800		$\text{V}/\mu\text{s}$
Gate Controlled Turn-On Time	$t_{gt}$	$I_{TM}=2\text{A}$ , $V_D=V_{DRM(\text{MAX})}$ , $I_G=10\text{mA}$ , $dI_G/dt=0.1\text{A}/\mu\text{s}$		2		$\mu\text{s}$
Circuit Commutated Turn-Off Time	$t_q$	$V_D=67\% V_{DRM(\text{MAX})}$ , $T_J=125^\circ\text{C}$ , $I_{TM}=1.6\text{A}$ , $V_R=35\text{V}$ , $dI_{TM}/dt=30\text{A}/\mu\text{s}$ , $V_D/dt=2\text{V}/\mu\text{s}$ , $R_{GK}=1\text{k}\Omega$		100		$\mu\text{s}$

■ TYPICAL CHARACTERISTICS

Maximum On-State Dissipation vs. Average On-State Current

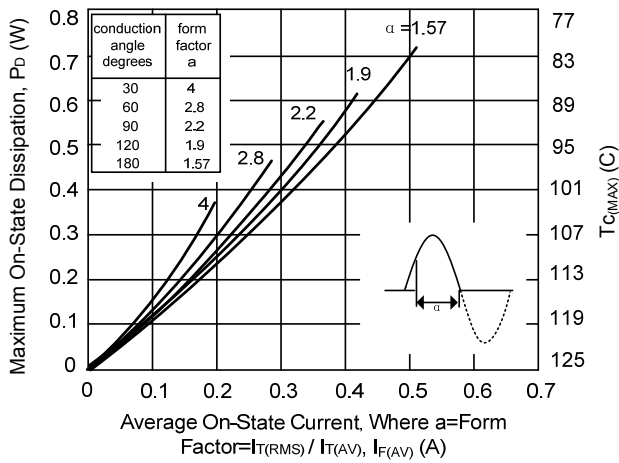

Maximum Permissible Non-Repetitive Peak On-State Current vs. Number Of Cycles

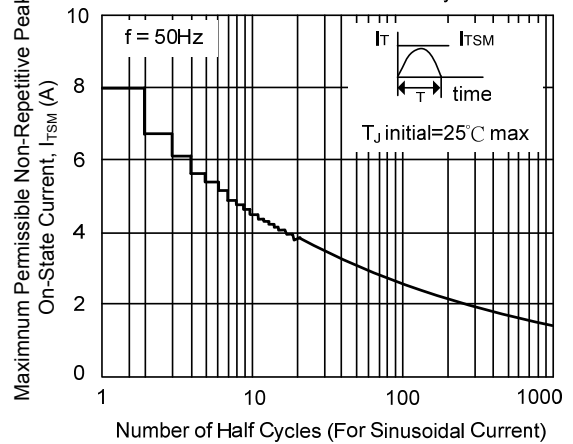

Maximum Permissible Non-Repetitive Peak On-State Current vs. Pulse Width tp, For Sinusoidal Current

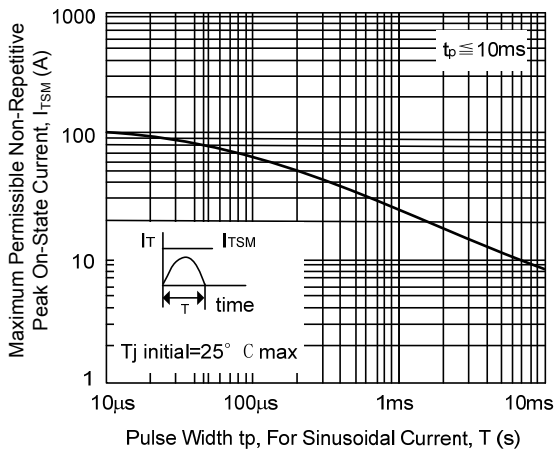

Maximum Permissible Repetitive RMS On-State Current vs. Surge Duration, For Sinusoidal Currents

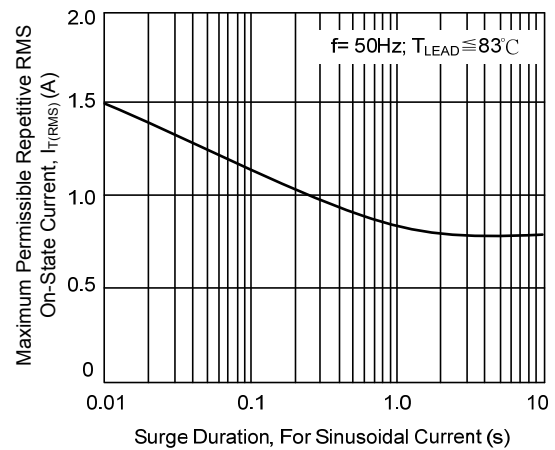

Maximum Permissible RMS Current vs. Lead Temperature

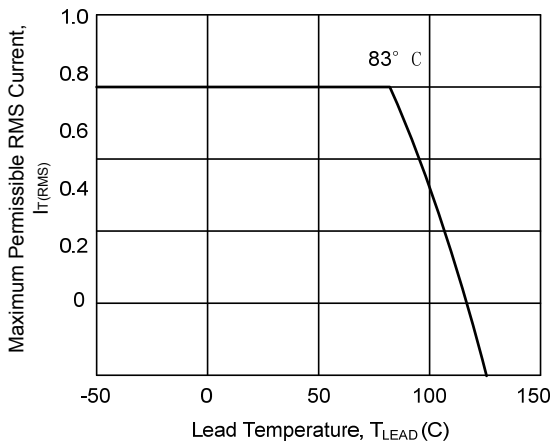

Normalised Gate Trigger Voltage vs. Junction Temperature

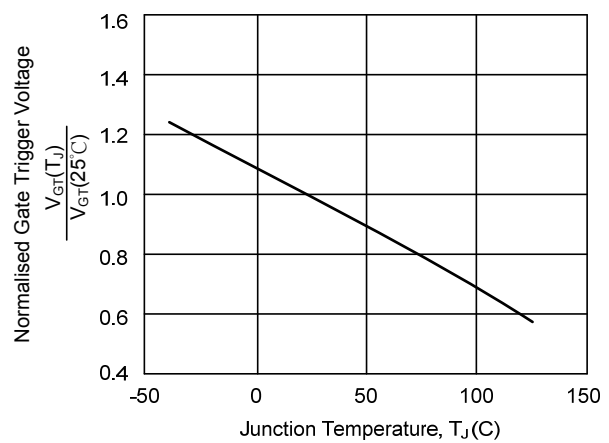

■ TYPICAL CHARACTERISTICS(Cont.)

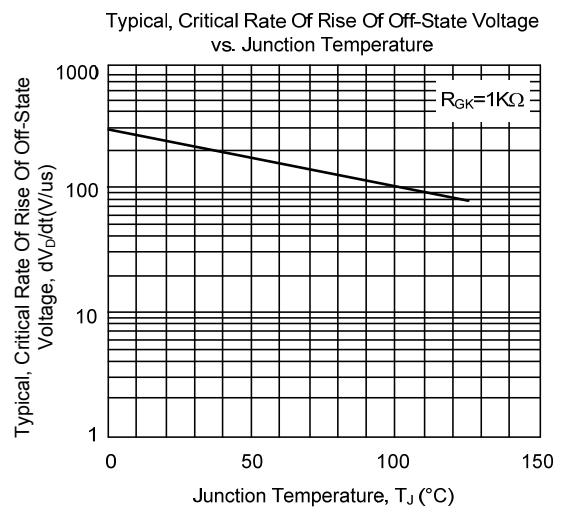
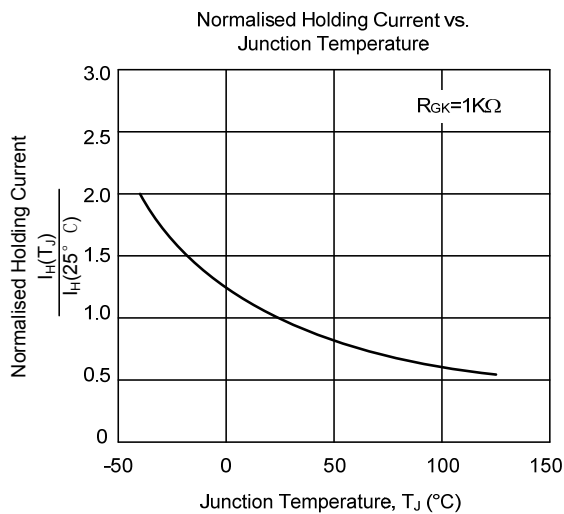
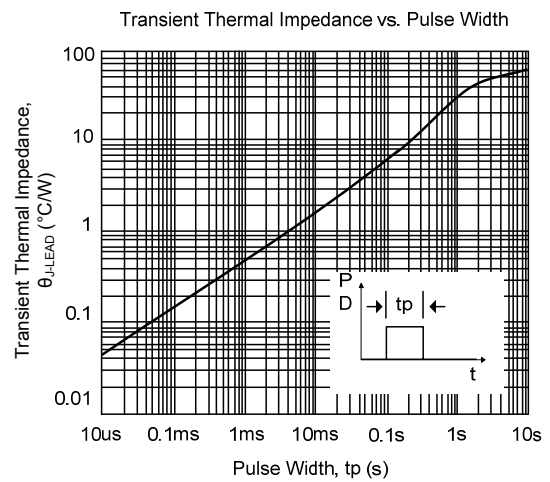
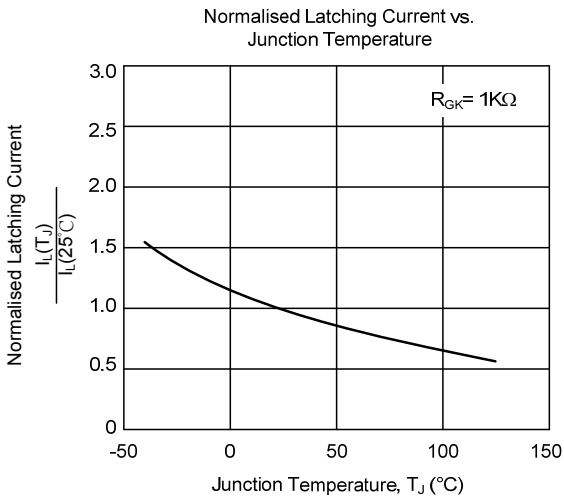
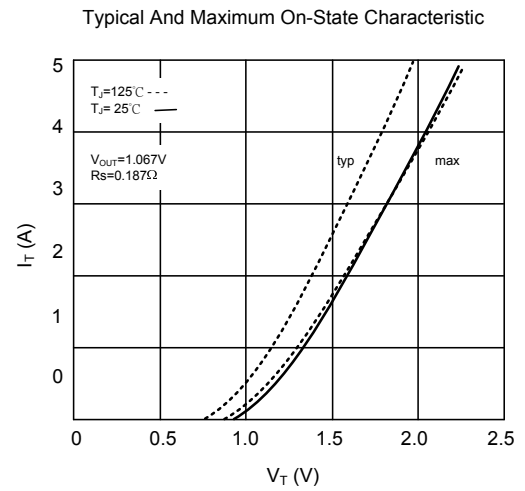
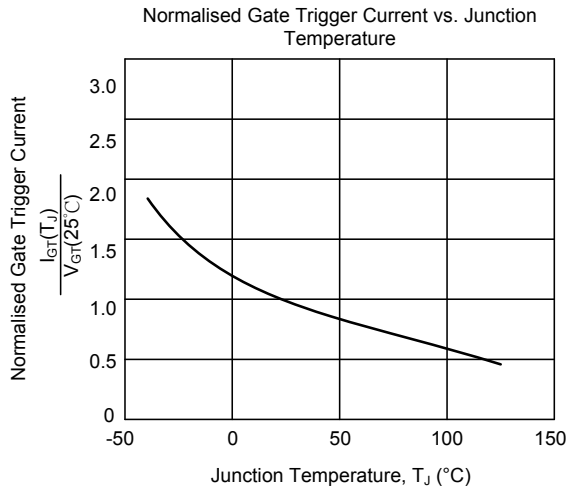

UTC assumes no responsibility for equipment failures that result from using products at values that exceed, even momentarily, rated values (such as maximum ratings, operating condition ranges, or other parameters) listed in products specifications of any and all UTC products described or contained herein. UTC products are not designed for use in life support appliances, devices or systems where malfunction of these products can be reasonably expected to result in personal injury. Reproduction in whole or in part is prohibited without the prior written consent of the copyright owner. The information presented in this document does not form part of any quotation or contract, is believed to be accurate and reliable and may be changed without notice.