

THYRISTOR MODULE

SCA (SCE) 160BA

UL; E76102 (M)

SCA (SCE) 160BA160

《Advantages》

- Isolated package
- $T_j \text{ max} = +150^\circ\text{C}$
- $I_{rrm}/I_{drms} = 100/100\text{mA}$ $T_j = 150^\circ\text{C}$
- di/dt 200A/ μs
- dv/dt 1000V/ μs
- $I_T(AV)$ 160A, $I_T(RMS)$ 251A, I_{TSM} 4500A

《Applications》

- Various rectifiers, motor drives, Heater controls and power supplies

《特長》

- 絶縁型パッケージ
- $T_j \text{ max} = +150^\circ\text{C}$
- 低オフ(リーク)電流 $I_{rrm}/I_{drms} = 100/100\text{mA}$ $T_j = 150^\circ\text{C}$
- di/dt 200A/ μs
- dv/dt 1000V/ μs
- $I_T(AV)$ 160A, $I_T(RMS)$ 251A, I_{TSM} 4500A

《用途》

- 整流器、モーター制御、ヒーター制御、各種電源装置

Internal Configurations 内部結線図

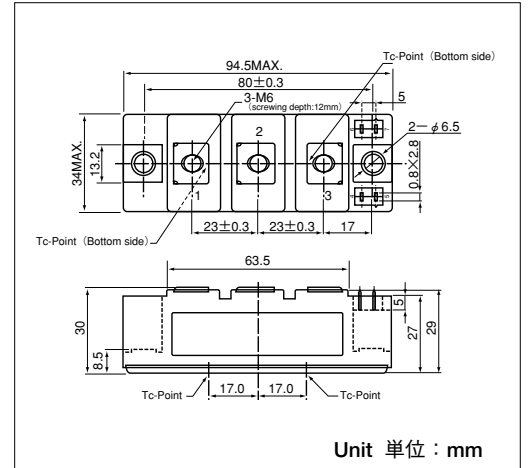
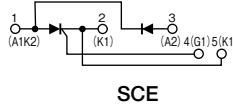
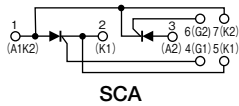

Maximum Ratings 最大定格

(Unless otherwise specified $T_j = 25^\circ\text{C}$ / 指定なき場合は $T_j = 25^\circ\text{C}$ とする)

Symbol 記号	Item 項目	Ratings 定格値		Unit 単位
		SCA160BA160 SCE160BA160		
V_{RRM}	*Repetitive Peak Reverse Voltage * 定格ピーク繰返し逆電圧	1600		V
V_{RSM}	*Non-Repetitive Peak Reverse Voltage * 定格ピーク非繰返し逆電圧	1700		V
V_{DRM}	Repetitive Peak Off-state Voltage 定格ピーク繰返しオフ電圧	1600		V

Symbol 記号	Item 項目	Conditions 条件	Ratings 定格値	Unit 単位
$I_T(AV)$ $I_F(AV)$	*Average On-state (Forward) Current * 定格平均オン(順)電流	Single phase, half wave, 180° conduction, $T_c = 102^\circ\text{C}$ 単相半波平均値 180° 導通角 $T_c = 102^\circ\text{C}$	160	A
$I_T(RMS)$ $I_F(RMS)$	*R.M.S. On-state (Forward) Current * 定格実効オン(順)電流	Single phase, half wave, 180° conduction, $T_c = 102^\circ\text{C}$ 単相半波実効値 180° 導通角 $T_c = 102^\circ\text{C}$	251	A
I_{TSM} I_{FSM}	*Surge On-state (Forward) Current * 定格サージオン(順)電流	$1/2$ cycle, 50/60Hz, Peak value, non-repetitive 50/60Hz 商用単相半波 1 サイクル波高値 非繰返し	4100/4500	A
I^2t	* I^2t * 電流二乗時間積	Value for one cycle surge current 定格サージオン電流に対する値	104000	A^2s
P_{GM}	Peak Gate Power Dissipation 定格ピークゲート損失		10	W
$P_{G(AV)}$	Average Gate Power Dissipation 定格平均ゲート損失		3	W
I_{FGM}	Peak Gate Current 定格ピークゲート順電流		3	A
V_{FGM}	Peak Gate Voltage (Forward) 定格ピークゲート順電圧		10	V
V_{RGM}	Peak Gate Voltage (Reverse) 定格ピークゲート逆電圧		5	V
di/dt	Critical Rate of Rise of On-state Current 定格臨界オン電流上昇率	$I_G = 100\text{mA}$, $V_D = 1/2 V_{DRM}$, $di_G/dt = 0.1\text{A}/\mu\text{s}$	200	$\text{A}/\mu\text{s}$
V_{ISO}	*Isolation Breakdown Voltage * 絶縁耐圧	A.C. 1minute 実効値, A.C. 1 分間	2500	V
T_j	*Operating Junction Temperature * 定格接合部温度		$-40 \sim +150$	$^\circ\text{C}$
T_{stg}	*Storage Temperature * 保存温度		$-40 \sim +125$	$^\circ\text{C}$
Mounting Torque 締付トルク	Mount (M6) 取付	Recommended value 推奨値	2.5~3.9N·m	N·m
	Terminal (M6) 主端子	Recommended value 推奨値	2.5~3.9N·m	
Mass 質量		Typical value 標準値	210	g

■Electrical Characteristics 電気的特性

(Unless otherwise specified Tj=25°C / 指定なき場合はTj=25°Cとする)

Symbol 記号	Item 項目	Conditions 条件	Ratings 定格値	Unit 単位
IDRM	Repetitive Peak Off-state Current, max 最大オフ電流	Tj=125°C, V _D =V _{DRM}	40	mA
		Tj=150°C, V _D =V _{DRM}	100	
IRRM	*Repetitive Peak Reverse Current, max *最大逆電流	Tj=125°C, V _R =V _{RRM}	40	mA
		Tj=150°C, V _R =V _{RRM}	100	
V _{TM} V _{FM}	*On-state (Forward) Voltage, max *最大オン(順)電圧	Tj=25°C, I _T =500A	1.65	V
		Tj=150°C, I _T =500A	1.75	
V _{T(TO)}	*Threshold Voltage, max *最大閾値電圧	Tj=25°C	1.15	V
		Tj=150°C	0.95	
r _t	*Dynamic Resistance, max *最大オン抵抗	Tj=25°C	1.0	mΩ
		Tj=150°C	1.6	
I _{GT}	Gate Trigger Current, max 最大ゲートトリガ電流	V _D =6V, I _T =1A	100	mA
V _{GT}	Gate Trigger Voltage, max 最大ゲートトリガ電圧	V _D =6V, I _T =1A	3	V
V _{GD}	Gate Non-Trigger Voltage, min 最小ゲート非トリガ電圧	Tj=125°C, V _D =½V _{DRM}	0.25	V
dv/dt	Critical Rate of Rise of Off-state Voltage, min 最小臨界オフ電圧上昇率	Tj=125°C, V _D =⅔V _{DRM} , exp. waveform 指数関数波形	1000	V/μs
R _{th(j-c)}	*Thermal Impedance, max *最大熱抵抗	cont., Junction to case, per one element 接合部-ケース間 cont., 単位エレメント当り	0.17	°C/W
R _{th(j-c)}	*Effective Thermal Impedance, max *最大実効熱抵抗	sin.180°, Junction to case, per one element 接合部-ケース間, sin.180°, 単位エレメント当り	0.18	°C/W
		rec.120°, Junction to case, per one element 接合部-ケース間, rec.120°, 単位エレメント当り	0.19	
R _{th(c-s)}	*Interface Thermal Impedance, max *最大接触熱抵抗	Case to Heat sink, per one element ケース-ヒートシンク間, 単位エレメント当り Thermal conductivity (Silicon grease)=7×10 ⁻³ [W/cm ² ·°C] シリコングリスの熱伝導率=7×10 ⁻³ [W/cm ² ·°C]	0.1	°C/W

*mark: Thyristor and Diode part, No mark: Thyristor part.

注) 上表中*印の項目は、サイリスタ部及びダイオード部の両方に適用します。その他の項目は主にサイリスタ部に適用します。

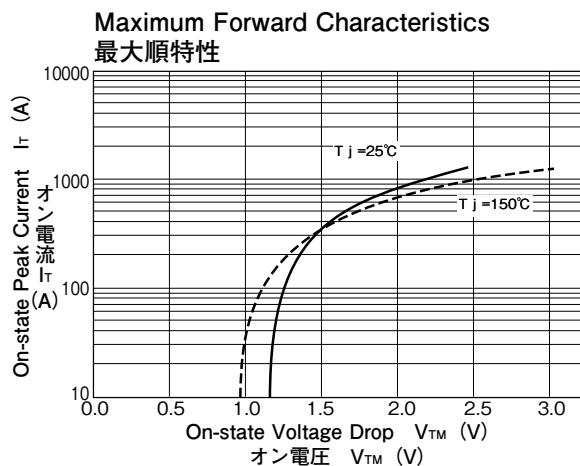
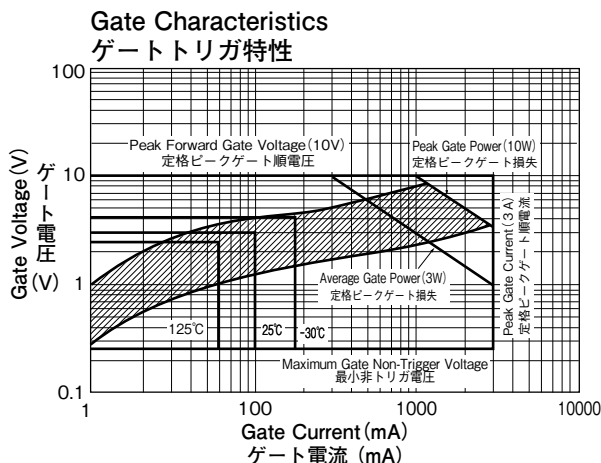

Surge Forward Current Rating (Non-Repetitive)
サージ順電流耐量 (非繰返し)

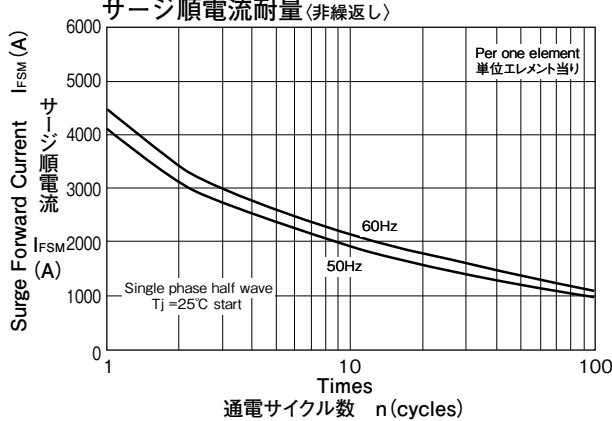

Transient Thermal Impedance
過熱インピーダンス特性

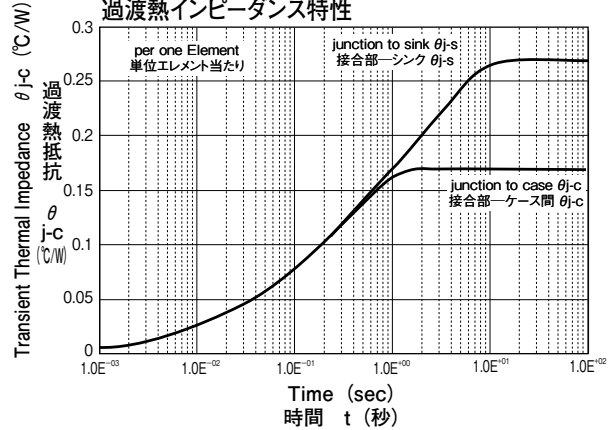

Current vs Power Dissipation
最大電力損失特性

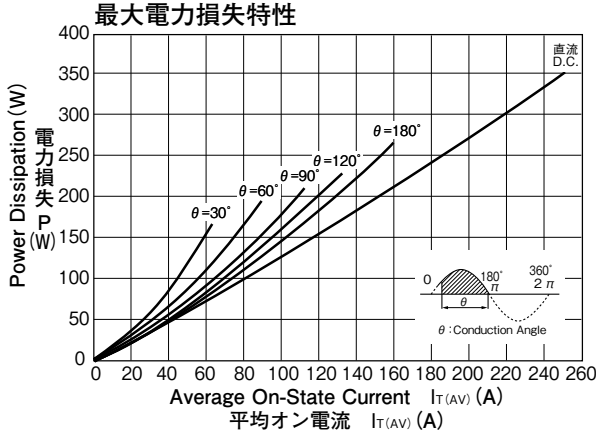

Current vs Allowable Case Temperature
電流対最大許容ケース温度

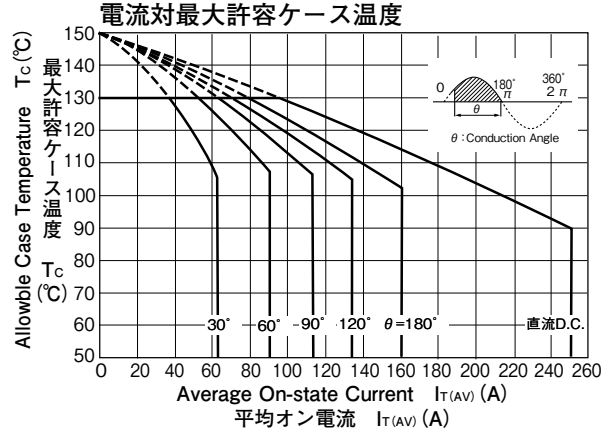

Output Current (W1; Bidirectional connection)
許容出力電流 (W1; 逆並列接続)

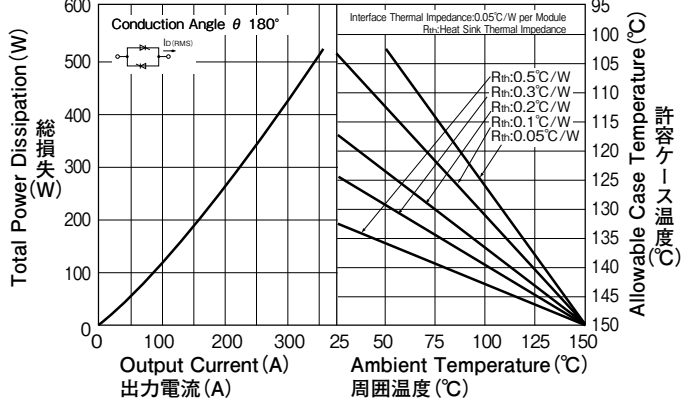

Output Current (B2; Two pulse bridge connection)
許容出力電流 (B2; 単相ブリッジ接続)

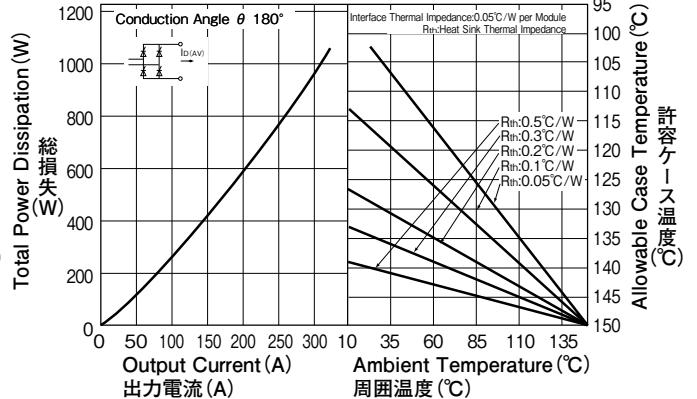

Output Current (B6; Six pulse bridge connection)
許容出力電流 (B6; 三相ブリッジ接続)

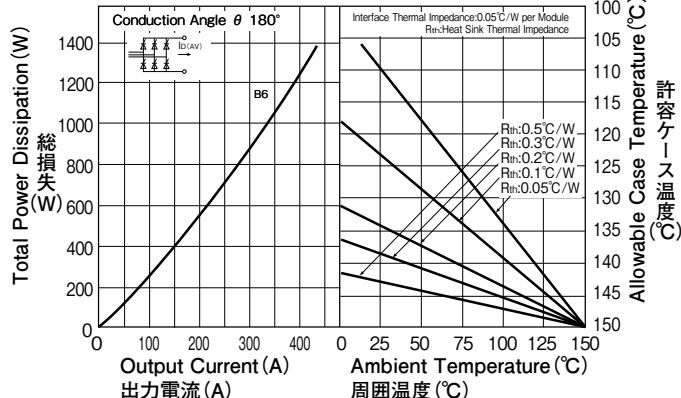

Output Current (W3; Three phase bidirectional connection)
許容出力電流 (W3; 三相逆並列接続)

