

CQDD-25M
CQDD-25N

**SURFACE MOUNT
25 AMP SILICON TRIAC
600 THRU 800 VOLTS**

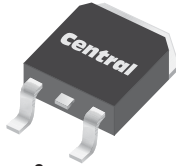

D²PAK CASE



www.centrasemi.com

DESCRIPTION:

The CENTRAL SEMICONDUCTOR CQDD-25M series type is an Epoxy Molded Silicon Triac designed for full wave AC control applications featuring gate triggering in all four (4) quadrants.

MARKING: FULL PART NUMBER

MAXIMUM RATINGS: ($T_C=25^\circ\text{C}$ unless otherwise noted)	SYMBOL	CQDD-25M	CQDD-25N	UNITS
Peak Repetitive Off-State Voltage	V_{DRM}	600	800	V
RMS On-State Current ($T_C=90^\circ\text{C}$)	$I_{T(RMS)}$	25		A
Peak One Cycle Surge, $t=8.3\text{ms}$	I_{TSM}	150		A
I^2t Value for Fusing, $t=8.3\text{ms}$	I^2t	94		A^2s
Peak Gate Power, $t_p=10\mu\text{s}$	P_{GM}	40		W
Average Gate Power Dissipation	$P_G (AV)$	1.0		W
Peak Gate Current, $t_p=10\mu\text{s}$	I_{GM}	10		A
Peak Gate Voltage, $t_p=10\mu\text{s}$	V_{GM}	16		V
Critical Rate of Rise of On-State Current Repetitive, $f=60\text{Hz}$	di/dt	10		$\text{A}/\mu\text{s}$
Operating Junction Temperature	T_J	-40 to +125		$^\circ\text{C}$
Storage Temperature	T_{stg}	-40 to +150		$^\circ\text{C}$
Thermal Resistance	θ_{JA}	60		$^\circ\text{C}/\text{W}$
Thermal Resistance	θ_{JC}	1.7		$^\circ\text{C}/\text{W}$

ELECTRICAL CHARACTERISTICS: ($T_C=25^\circ\text{C}$ unless otherwise noted)

SYMBOL	TEST CONDITIONS	MIN	TYP	MAX	UNITS
I_{DRM}	Rated V_{DRM}			10	μA
I_{DRM}	Rated V_{DRM} , $T_C=125^\circ\text{C}$			2.0	mA
I_{GT}	$V_D=12\text{V}$, $R_L=10\Omega$, QUAD I, II, III		11.1	30	mA
I_{GT}	$V_D=12\text{V}$, $R_L=10\Omega$, QUAD IV		28.2	60	mA
I_H	$I_T=100\text{mA}$		18.4	50	mA
V_{GT}	$V_D=12\text{V}$, $R_L=10\Omega$, QUAD I, II, III		1.03	1.50	V
V_{GT}	$V_D=12\text{V}$, $R_L=10\Omega$, QUAD IV		1.74	2.50	V
V_{TM}	$I_{TM}=35\text{A}$, $t_p=380\mu\text{s}$			1.80	V
dv/dt	$V_D=2/3 V_{DRM}$, $R_{GK}=\infty$, $T_C=125^\circ\text{C}$	6.0			$\text{V}/\mu\text{s}$

R2 (12-February 2010)

CQDD-25M
CQDD-25N

SURFACE MOUNT
25 AMP SILICON TRIAC
600 THRU 800 VOLTS



D²PAK CASE - MECHANICAL OUTLINE

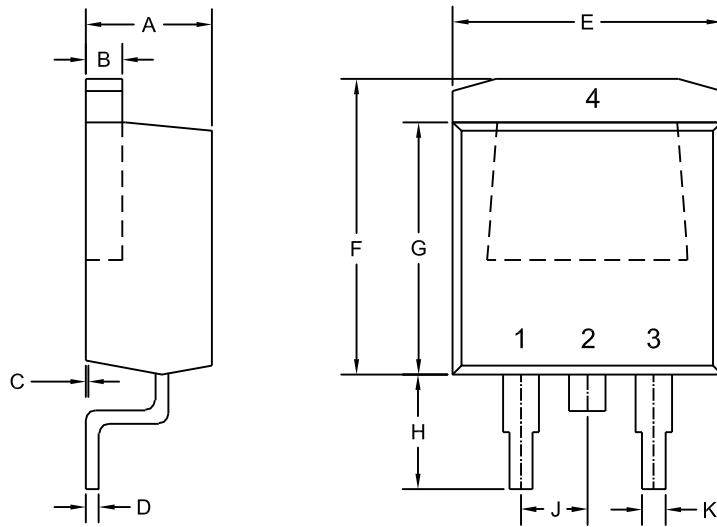

R2

LEAD CODE:

- 1) MT1
- 2) MT2
- 3) Gate
- 4) MT2

MARKING:

FULL PART NUMBER

DIMENSIONS				
SYMBOL	INCHES		MILLIMETERS	
	MIN	MAX	MIN	MAX
A	0.163	0.189	4.14	4.80
B	0.045	0.055	1.14	1.40
C	0.000	0.010	0.00	0.25
D	0.012	0.028	0.30	0.70
E	0.386	0.409	9.80	10.40
F	0.378	0.417	9.60	10.60
G	0.335	0.358	8.50	9.10
H	0.197	0.236	5.00	6.00
J	0.093	0.108	2.35	2.75
K	0.030	0.035	0.75	0.90

D2PAK (REV: R2)

R2 (12-February 2010)