

High-Current Switching Applications

2SB1216

■ Features

- Low collector-to-emitter saturation voltage.
- Good linearity of hFE.
- High fT.
- Fast switching time.

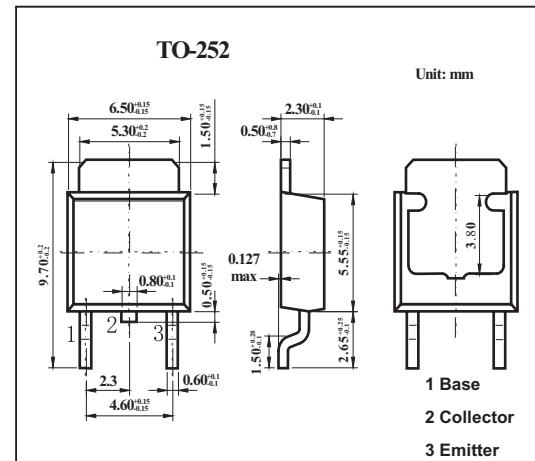

■ Absolute Maximum Ratings Ta = 25°C

Parameter	Symbol	Rating	Unit
Collector-base voltage	V _{CB0}	-120	V
Collector-emitter voltage	V _{CE0}	-100	V
Emitter-base voltage	V _{EB0}	-6	V
Collector current	I _C	-4	A
Collector current (pulse)	I _{CP}	-8	A
Collector dissipation	P _C	1	W
T _C = 25°C		20	W
Junction temperature	T _J	150	°C
Storage temperature	T _{stg}	-55 to +150	°C

2SB1216

■ Electrical Characteristics Ta = 25°C

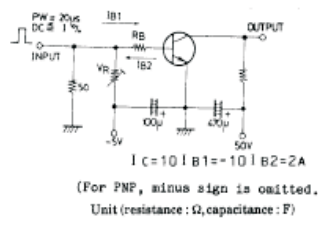
Parameter	Symbol	Testconditons	Min	Typ	Max	Unit	
Collector cutoff current	ICBO	V _{CB} = -100V , I _E = 0			-1	μA	
Emitter cutoff current	IEBO	V _{EB} = -4V , I _C = 0			-1	μA	
DC current Gain	h _{FE}	V _{CE} = -5V , I _C = -0.5A	70		400		
		V _{CE} = -5V , I _C = -3A	40				
Gain bandwidth product	f _T	V _{CE} = -10V , I _C = -0.5A		130		MHz	
Output capacitance	C _{ob}	V _{CB} = -10V , f = 1MHz		65		pF	
Collector-emitter saturation voltage	V _{CE(sat)}	I _C = -2A , I _B = -0.2A		-200	-500	mV	
Base-to-emitter saturation voltage	V _{BE(sat)}	I _C = -2A , I _B = -0.2A		-0.9	-1.2	V	
Collector-to-base breakdown voltage	V _{(BR)CBO}	I _C = -10μA , I _E = 0	-120			V	
Collector-to-emitter breakdown voltage	V _{(BR)CEO}	I _C = -1mA , R _{BE} = ∞	-100			V	
Emitter-to-base breakdown voltage	V _{(BR)EBO}	I _E = -10μA , I _C = 0	-6			V	
Turn-on time	t _{on}	 <p>IC = 10mA IB1 = -10mA IB2 = 2mA (For PNP, minus sign is omitted.) Unit (resistance : Ω, capacitance : F)</p>		100		ns	
Storage time	t _{stg}				800		ns
Fall time	t _f				50		ns

■ hFE Classification

Rank	Q	R	S	T
hFE	70~140	100~200	140~280	200~400