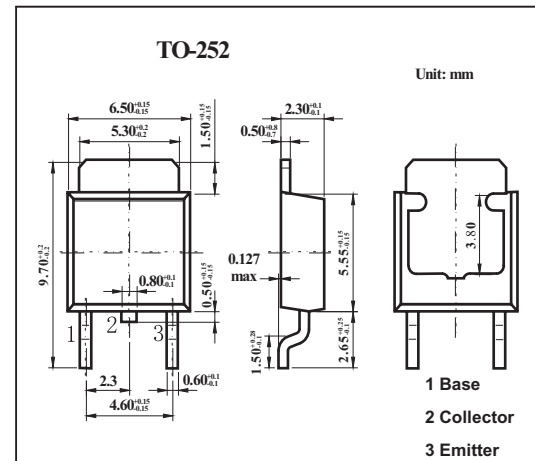

High-Current Switching Applications

2SB1202

■ Features

- Low collector-to-emitter saturation voltage.
- Fast switching speed.

■ Absolute Maximum Ratings $T_a = 25^\circ\text{C}$

Parameter	Symbol	Rating	Unit
Collector-base voltage	V_{CB0}	-60	V
Collector-emitter voltage	V_{CE0}	-50	V
Emitter-base voltage	V_{EB0}	-6	V
Collector current	I_C	-3	A
Collector current (pulse)	I_{CP}	-6	A
Collector dissipation $T_C = 25^\circ\text{C}$	P_C	1	W
		15	W
Junction temperature	T_j	150	$^\circ\text{C}$
Storage temperature	T_{stg}	-55 to +150	$^\circ\text{C}$

2SB1202

■ Electrical Characteristics Ta = 25°C

Parameter	Symbol	Testconditons	Min	Typ	Max	Unit	
Collector cutoff current	I _{CBO}	V _{CB} = -40V, I _E = 0			-1	μA	
Emitter cutoff current	I _{EBO}	V _{EB} = -4V, I _C = 0			-1	μA	
DC current Gain	h _{FE}	V _{CE} = -2V, I _C = -100mA	100		560		
		V _{CE} = -2V, I _C = -3A	35				
Gain bandwidth product	f _T	V _{CE} = -10V, I _C = -50mA		150		MHz	
Output capacitance	C _{ob}	V _{CB} = -10V, f = 1MHz		39		pF	
Collector-emitter saturation voltage	V _{CE(sat)}	I _C = -2A, I _B = -100mA		-0.35	-0.7	V	
Base-to-emitter saturation voltage	V _{BE(sat)}	I _C = -2A, I _B = -100mA		-0.94	-1.2	V	
Collector-to-base breakdown voltage	V _{(BR)CBO}	I _C = -10μA, I _E = 0	-60			V	
Collector-to-emitter breakdown voltage	V _{(BR)CEO}	I _C = -1mA, R _{BE} = ∞	-50			V	
Emitter-to-base breakdown voltage	V _{(BR)EBO}	I _E = -10μA, I _C = 0	-6			V	
Turn-on time	t _{on}	<p>I_C = 10 I_{B1} = -10 I_{B2} = 1 A (For PNP, the polarity is reversed.) Unit (resistance : Ω, capacitance : F)</p>		70		ns	
Storage time	t _{stg}				450		ns
Fall time	t _f				35		ns

■ hFE Classification

Rank	R	S	T	U
hFE	100~200	140~280	200~400	280~560