

**MSAFX50N20A**

**Features**

- Ultrafast body diode
- Rugged polysilicon gate cell structure
- Increased Unclamped Inductive Switching (UIS) capability
- Hermetically sealed, surface mount power package
- Low package inductance
- Very low thermal resistance
- Reverse polarity available upon request

**200 Volts**  
**50 Amps**  
**45 mΩ**

**N-CHANNEL**  
**ENHANCEMENT MODE**  
**POWER MOSFET**

**Maximum Ratings @ 25°C (unless otherwise specified)**

DESCRIPTION	SYMBOL	MAX.	UNIT
Drain-to-Source Breakdown Voltage (Gate Shorted to Source) @ T <sub>J</sub> ≥ 25°C	BV <sub>DSS</sub>	200	Volts
Drain-to-Gate Breakdown Voltage @ T <sub>J</sub> ≥ 25°C, R <sub>GS</sub> = 1 MΩ	BV <sub>DGR</sub>	200	Volts
Continuous Gate-to-Source Voltage	V <sub>GS</sub>	+/-20	Volts
Transient Gate-to-Source Voltage	V <sub>GSM</sub>	+/-30	Volts
Continuous Drain Current 100°C	I <sub>D25</sub> I <sub>D100</sub>	50 40	Amps
Peak Drain Current, pulse width limited by T <sub>Jmax</sub>	I <sub>DM</sub>	200	Amps
Repetitive Avalanche Current	I <sub>AR</sub>	50	Amps
Repetitive Avalanche Energy	E <sub>AR</sub>	30	mJ
Single Pulse Avalanche Energy	E <sub>AS</sub>	tbd	mJ
Voltage Rate of Change of the Recovery Diode @ I <sub>S</sub> ≤ I <sub>DM</sub> , di/dt ≤ 100 A/μs, V <sub>DD</sub> ≤ V <sub>DSS</sub> , T <sub>J</sub> ≤ 150°C	dv/dt	5.0	V/ns
Power Dissipation	P <sub>D</sub>	300	Watts
Junction Temperature Range	T <sub>J</sub>	-55 to +150	°C
Storage Temperature Range	T <sub>stg</sub>	-55 to +150	°C
Continuous Source Current (Body Diode)	I <sub>S</sub>	50	Amps
Pulse Source Current (Body Diode)	I <sub>SM</sub>	200	Amps
Thermal Resistance, Junction to Case	θ <sub>JC</sub>	0.25	°C/W

**Mechanical Outline**

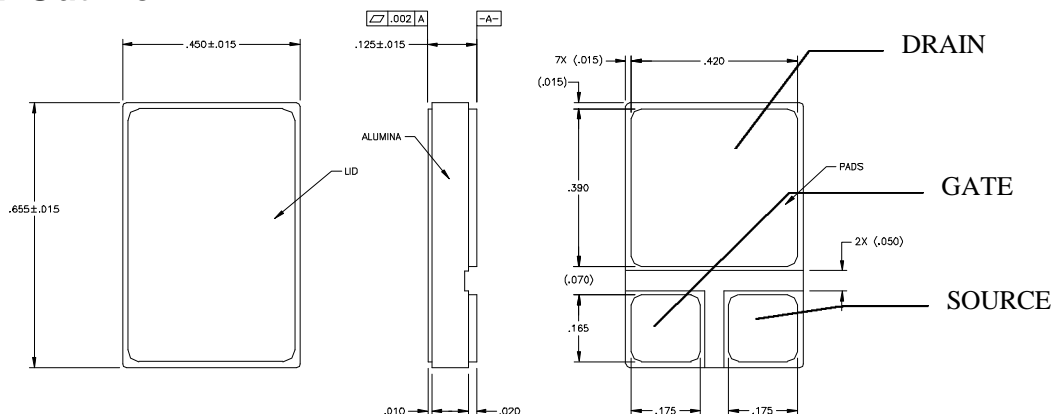

# MSAFX50N20A

## Electrical Parameters @ 25°C (unless otherwise specified)

DESCRIPTION	SYMBOL	CONDITIONS	MIN	TYP.	MAX	UNIT
Drain-to-Source Breakdown Voltage (Gate Shorted to Source)	$BV_{DSS}$	$V_{GS} = 0\text{ V}, I_D = 250\ \mu\text{A}$	200			V
Temperature Coefficient of the Drain-to-Source Breakdown Voltage	$\Delta BV_{DSS}/\Delta T_J$			tbd		V/°C
Gate Threshold Voltage	$V_{GS(th)}$	$V_{DS} = V_{GS}, I_D = 4\ \text{mA}$	2.0		4.0	V
Gate-to-Source Leakage Current	$I_{GSS}$	$V_{GS} = \pm 20\text{V}_{DC}, V_{DS} = 0\ \text{T}_J = 25^\circ\text{C}$ $\text{T}_J = 125^\circ\text{C}$			$\pm 100$ $\pm 200$	nA
Drain-to-Source Leakage Current (Zero Gate Voltage Drain Current)	$I_{DSS}$	$V_{DS} = 0.8 \cdot BV_{DSS}\ \text{T}_J = 25^\circ\text{C}$ $V_{GS} = 0\ \text{T}_J = 125^\circ\text{C}$			200 1000	$\mu\text{A}$
Static Drain-to-Source On-State Resistance (1)	$R_{DS(on)}$	$V_{GS} = 10\text{V}, I_D = 25\text{A}\ \text{T}_J = 25^\circ\text{C}$ $I_D = 50\text{A}\ \text{T}_J = 25^\circ\text{C}$ $I_D = 25\text{A}\ \text{T}_J = 125^\circ\text{C}$		0.09	0.045 0.055	$\Omega$
Forward Transconductance (1)	$g_{fs}$	$V_{DS} \geq 10\ \text{V}; I_D = 50\ \text{A}$	26	32		S
Input Capacitance Output Capacitance Reverse Transfer Capacitance	$C_{iss}$ $C_{oss}$ $C_{rss}$	$V_{GS} = 0\ \text{V}, V_{DS} = 25\ \text{V}, f = 1\ \text{MHz}$		4400 800 285		pF
Turn-on Delay Time Rise Time Turn-off Delay Time Fall Time	$T_{d(on)}$ $t_r$ $t_{d(off)}$ $t_f$	$V_{GS} = 10\ \text{V}, V_{DS} = 100\ \text{V},$ $I_D = 25\ \text{A}, R_G = 2.00\ \Omega$		20 15 75 20	25 20 90 25	ns
Total Gate Charge Gate-to-Source Charge Gate-to-Drain (Miller) Charge	$Q_{g(on)}$ $Q_{gs}$ $Q_{gd}$	$V_{GS} = 10\ \text{V}, V_{DS} = 100\text{V}, I_D = 25\text{A}$		190 35 95	220 50 110	nC
Body Diode Forward Voltage (1)	$V_{SD}$	$I_F = I_S, V_{GS} = 0\ \text{V}$			1.5	V
Reverse Recovery Time (Body Diode)	$t_{rr}$	$I_F = 10\ \text{A},$ $-di/dt = 100\ \text{A}/\mu\text{s},$	25 C 125 C		200 300	ns
Reverse Recovery Charge	$Q_{rr}$	$I_F = 10\ \text{A},$ $di/dt = 100\ \text{A}/\mu\text{s},$	25 C 125 C		1.5 2.6	$\mu\text{C}$

### Notes

- (1) Pulse test,  $t \leq 300\ \mu\text{s}$ , duty cycle  $\delta \leq 2\%$
- (2) Microsemi Corp. does not manufacture the mosfet die; contact company for details.

**This datasheet has been downloaded from:**

**[www.EEworld.com.cn](http://www.EEworld.com.cn)**

**Free Download**

**Daily Updated Database**

**100% Free Datasheet Search Site**

**100% Free IC Replacement Search Site**

**Convenient Electronic Dictionary**

**Fast Search System**

**[www.EEworld.com.cn](http://www.EEworld.com.cn)**