

MSAFX40N30A

300 Volts
40 Amps
85 mΩ

N-CHANNEL
ENHANCEMENT MODE
POWER MOSFET

Features

- Ultrafast body diode
- Rugged polysilicon gate cell structure
- Increased Unclamped Inductive Switching (UIS) capability
- Hermetically sealed, surface mount power package
- Low package inductance
- Very low thermal resistance
- Reverse polarity available upon request

Maximum Ratings @ 25°C (unless otherwise specified)

DESCRIPTION	SYMBOL	MAX.	UNIT
Drain-to-Source Breakdown Voltage (Gate Shorted to Source) @ $T_J \geq 25^\circ\text{C}$	BV_{DSS}	300	Volts
Drain-to-Gate Breakdown Voltage @ $T_J \geq 25^\circ\text{C}$, $R_{GS} = 1\text{ M}\Omega$	BV_{DGR}	300	Volts
Continuous Gate-to-Source Voltage	V_{GS}	+/-20	Volts
Transient Gate-to-Source Voltage	V_{GSM}	+/-30	Volts
Continuous Drain Current $T_J = 25^\circ\text{C}$ $T_J = 100^\circ\text{C}$	I_{D25} I_{D100}	40 30	Amps
Peak Drain Current, pulse width limited by T_{Jmax}	I_{DM}	160	Amps
Repetitive Avalanche Current	I_{AR}	40	Amps
Repetitive Avalanche Energy	E_{AR}	30	mJ
Single Pulse Avalanche Energy	E_{AS}	tbd	mJ
Voltage Rate of Change of the Recovery Diode @ $I_S \leq I_{DM}$, $di/dt \leq 100\text{ A}/\mu\text{s}$, $V_{DD} \leq V_{DSS}$, $T_J \leq 150^\circ\text{C}$	dv/dt	5.0	V/ns
Power Dissipation	P_D	300	Watts
Junction Temperature Range	T_J	-55 to +150	°C
Storage Temperature Range	T_{stg}	-55 to +150	°C
Continuous Source Current (Body Diode)	I_S	40	Amps
Pulse Source Current (Body Diode)	I_{SM}	160	Amps
Thermal Resistance, Junction to Case	θ_{JC}	0.25	°C/W

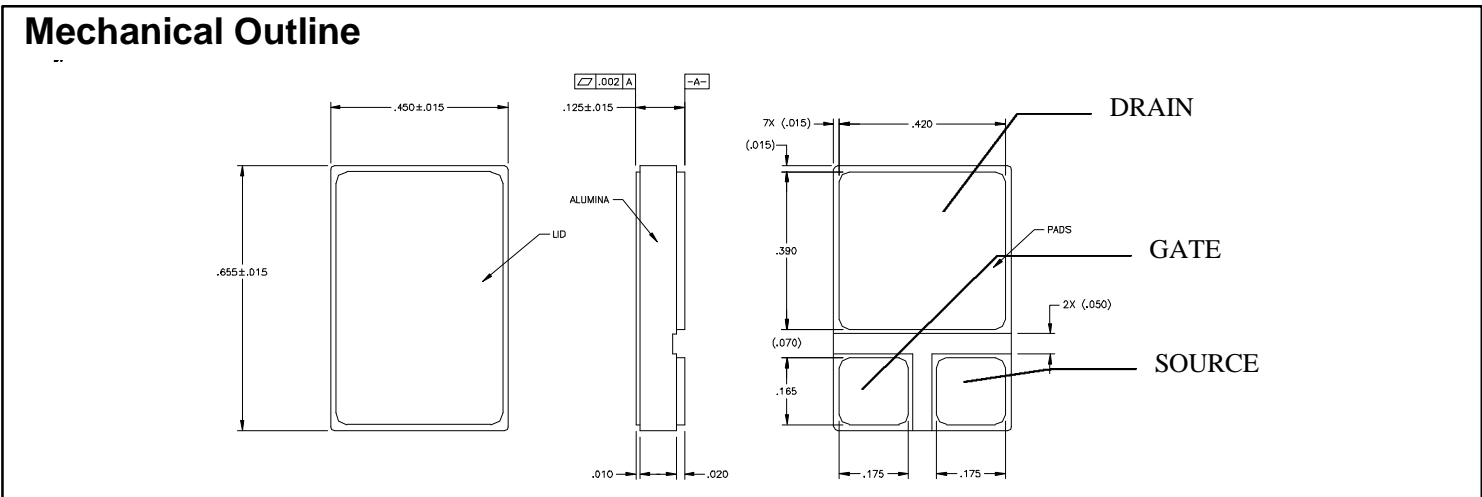

MSAFX40N30A

Electrical Parameters @ 25°C (unless otherwise specified)

DESCRIPTION	SYMBOL	CONDITIONS	MIN	TYP.	MAX	UNIT
Drain-to-Source Breakdown Voltage (Gate Shorted to Source)	BV_{DSS}	$V_{GS} = 0\text{ V}, I_D = 250\ \mu\text{A}$	300			V
Temperature Coefficient of the Drain-to-Source Breakdown Voltage	$\Delta BV_{DSS}/\Delta T_J$			tbd		V/°C
Gate Threshold Voltage	$V_{GS(th)}$	$V_{DS} = V_{GS}, I_D = 4\ \text{mA}$	2.0		4.0	V
Gate-to-Source Leakage Current	I_{GSS}	$V_{GS} = \pm 20\text{V}_{DC}, V_{DS} = 0\ \text{T}_J = 25^\circ\text{C}$ $\text{T}_J = 125^\circ\text{C}$			± 100 ± 200	nA
Drain-to-Source Leakage Current (Zero Gate Voltage Drain Current)	I_{DSS}	$V_{DS} = 0.8 \cdot BV_{DSS}\ \text{T}_J = 25^\circ\text{C}$ $V_{GS} = 0\ \text{V}\ \text{T}_J = 125^\circ\text{C}$			200 1000	μA
Static Drain-to-Source On-State Resistance (1)	$R_{DS(on)}$	$V_{GS} = 10\text{V}, I_D = 20\ \text{A}\ \text{T}_J = 25^\circ\text{C}$ $I_D = 40\ \text{A}\ \text{T}_J = 25^\circ\text{C}$ $I_D = 20\ \text{A}\ \text{T}_J = 125^\circ\text{C}$		0.085 0.17	0.085	Ω
Forward Transconductance (1)	g_{fs}	$V_{DS} \geq 10\ \text{V}; I_D = 40\ \text{A}$	22	25		S
Input Capacitance Output Capacitance Reverse Transfer Capacitance	C_{iss} C_{oss} C_{rss}	$V_{GS} = 0\ \text{V}, V_{DS} = 25\ \text{V}, f = 1\ \text{MHz}$		4800 745 280		pF
Turn-on Delay Time Rise Time Turn-off Delay Time Fall Time	$T_{d(on)}$ t_r $t_{d(off)}$ t_f	$V_{GS} = 10\ \text{V}, V_{DS} = 150\ \text{V},$ $I_D = 20\ \text{A}, R_G = 2.00\ \Omega$		20 60 75 45	30 90 100 90	ns
Total Gate Charge Gate-to-Source Charge Gate-to-Drain (Miller) Charge	$Q_{g(on)}$ Q_{gs} Q_{gd}	$V_{GS} = 10\ \text{V}, V_{DS} = 150\text{V}, I_D = 20\text{A}$		180 30 80	200 50 105	nC
Body Diode Forward Voltage (1)	V_{SD}	$I_F = I_S, V_{GS} = 0\ \text{V}$			1.5	V
Reverse Recovery Time (Body Diode)	t_{rr}	$I_F = 10\ \text{A},$ $-di/dt = 100\ \text{A}/\mu\text{s},$ 25 C 125 C			200 350	ns
Reverse Recovery Charge	Q_{rr}	$I_F = 10\ \text{A},$ $di/dt = 100\ \text{A}/\mu\text{s},$ 25 C 125 C			tbd tbd	μC

Notes

- (1) Pulse test, $t \leq 300\ \mu\text{s}$, duty cycle $\delta \leq 2\%$
- (2) Microsemi Corp. does not manufacture the mosfet die; contact company for details.

This datasheet has been downloaded from:

www.EEworld.com.cn

Free Download

Daily Updated Database

100% Free Datasheet Search Site

100% Free IC Replacement Search Site

Convenient Electronic Dictionary

Fast Search System

www.EEworld.com.cn