

NPN EPITAXIAL SILICON TRANSISTOR

PRE-AMPLIFIER, LOW LEVEL & LOW NOISE

- * Complement to S9015LT1
- * Collector Current: $I_c = 100\text{mA}$
- * Collector-Emitter Voltage: $V_{ce} = 45\text{V}$
- * High Total Power Dissipation: $P_c = 225\text{mW}$
- * High H_{fe} And Good Linearity

ABSOLUTE MAXIMUM RATINGS at $T_a = 25^\circ\text{C}$

Characteristic	Symbol	Rating	Unit
Collector-Base Voltage	V_{cbo}	50	V
Collector-Emitter Voltage	V_{ceo}	45	V
Emitter-Base Voltage	V_{ebo}	5	V
Collector Current	I_c	100	mA
Collector Dissipation $T_a = 25^\circ\text{C}^*$	P_D	225	mW
Junction Temperature	T_j	150	$^\circ\text{C}$
Storage Temperature	T_{stg}	-55-150	$^\circ\text{C}$

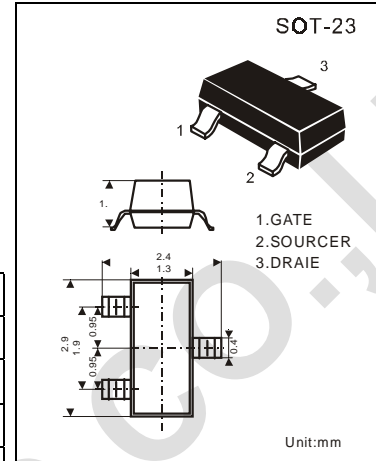

ELECTRICAL CHARACTERISTICS at $T_a = 25^\circ\text{C}$

Characteristic	Symbol	Min	Typ	Max	Unit	Test Conditions
Collector-Base Breakdown Voltage	BV_{cbo}	50			V	$I_c = 100\mu\text{A}$ $I_e = 0$
Collector-Emitter Breakdown Voltage#	BV_{ceo}	45			V	$I_c = 1\text{mA}$ $I_b = 0$
Emitter-Base Breakdown Voltage	BV_{ebo}	5			V	$I_e = 100\mu\text{A}$ $I_c = 0$
Collector-Base Cutoff Current	I_{cbo}			50	nA	$V_{cb} = 50\text{V}$ $I_e = 0$
Emitter-Base Cutoff Current	I_{ebo}			50	nA	$V_{eb} = 5\text{V}$ $I_c = 0$
DC Current Gain	H_{fe}	135	270	1000		$V_{ce} = 5\text{V}$ $I_c = 1\text{mA}$
Collector-Emitter Saturation Voltage	$V_{ce(sat)}$			0.3	V	$I_c = 100\text{mA}$ $I_b = 5\text{mA}$
Base-Emitter Saturation Voltage	$V_{be(sat)}$			1.00	V	$I_c = 100\text{mA}$ $I_b = 5\text{mA}$
Base-Emitter on Voltage	$V_{be(on)}$	0.58	0.63	0.7	V	$V_{ce} = 5\text{V}$ $I_c = 2\text{mA}$
Output Capacitance	C_{ob}		2.2	3.5	PF	$V_{cb} = 10\text{V}$ $I_e = 0$ $f = 1\text{MHz}$
Current Gain-Bandwidth Product	f_T	150	270		MHz	$V_{ce} = 5\text{V}$ $I_c = 10\text{mA}$
Noise Figure	NF			10	dB	$V_{ce} = 5\text{V}$ $I_c = 0.2\text{mA}$ $f = 1\text{KHz}$ $R_s = 2\text{Kohm}$

* Total Device Dissipation : $FR = 1 \times 0.75 \times 0.062$ in Board, Derate 25°C .

Pulse Test : Pulse Width $\leq 300\mu\text{s}$, Duty cycle $\leq 2\%$

DEVICE MARKING:

2SD601LT1=L5